

LUBRICATION ORDER
TECHNICAL ORDER
13 MARCH 1992

LO 9-2805-257-12
TO 38G2-103-2LC-1
(Supersedes LO 9-2805-257-12, 21 November 1986)

ENGINE, GASOLINE, 3 HP,
MILITARY STANDARD MODELS

(MODEL 2A016-1, NSN 2805-00-601-5127)
(MODEL 2A016-2, NSN 2805-00-714-8553)
(MODEL 2A016-3, NSN 2805-00-072-4871)
(MODEL 2A016-4, NSN 2805-01-169-1100)

References: TM 9-2805-257-14, C9100-IL and FM 9-207

REPORTING OF ERRORS AND RECOMMENDING IMPROVEMENTS

You can help improve this publication. If you find any mistakes or if you know of a way to improve the procedures, please let us know. Mail your letter or DA Form 2028 (Recommended Changes to Publications and Blank Forms), directly to: US Army Troop Support Command, ATTN: AMSTR-MMTS, 4300 Goodfellow Blvd., St. Louis, MO 53120-1798. A reply will be furnished directly to you.

DISTRIBUTION STATEMENT A - Approved for public release; distribution is unlimited

NOTES

This LO is for crew/operator (C) or organizational (O) maintenance. Lube intervals (on-condition or hard time) and task hour times are based on normal hours of operation. Change the intervals if your lubricants are contaminated or if you are operating the equipment under adverse operating conditions. Lube more during constant use and less during periods of low activity. Adequate preservation precautions must be taken during inactive periods. Use correct grade of lubricant for seasonal temperature expected.

WARNING - Dry cleaning solvent PD-680 used to clean parts is potentially dangerous to personnel and property. Avoid repeated and prolonged skin contact. Do not use near open flame or excessive heat. Flash point of solvent is 100°F-138°F(38°C-60°C).

Clean parts with dry cleaning solvent PD-680 and dry before lubricating.

Before you start your lube service.

ALWAYS

- a. Clean parts before lubricating.
- b. Use the lubrication order as your guide.

NEVER

- a. Use wrong type/grade lubricant
- b. Use too much lubricant.

The 3 HP military standard gasoline engine is not enrolled in the Army Oil Analysis Program (AOAP) HARD TIME INTERVALS APPLY.

LO 9-2805-257-12
 TO 38G2-103-2LC-1

*TOTAL TASK-HR		*TOTAL TASK-HR	
INTERVAL	TASK-HR	INTERVAL	TASK-HR
8	0.5	500	0.3
50	1.5		

*The time specified is the time required to perform all services at the particular interval (on-condition or hard time)

LUBRICANT • INTERVAL

INTERVAL • LUBRICANT

Crankcase Fill and Level
 (Check level)
 (See table 1) (C)
 OE/
 HDO

CAUTION: When OEA
 oil is used the level will be
 checked more often

Ignition CamWick
 (O) (Sparingly)
 (See note 3)
 OE/
 HDO

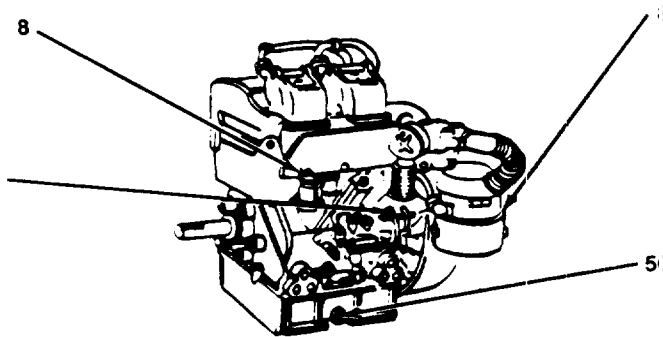

OE/ Air Cleaner
 HDO (Refill oil reservoir
 to level mark; every
 50 hours disassemble
 entire unit, clean, re-
 oil and reassemble)
 (See table 1) (O)

OE/ Crankcase Drain
 HDO (Drain and refill)
 (See note 4) (O)

MODELS 2A016-1 AND 2A016-2

LUBRICANT • INTERVAL

INTERVAL • LUBRICANT

Crankcase Fill and
 Level
 (Check level)
 (See table 1) (C)
 OE/
 HDO

CAUTION: When OEA
 oil is used the level will be
 checked more often.

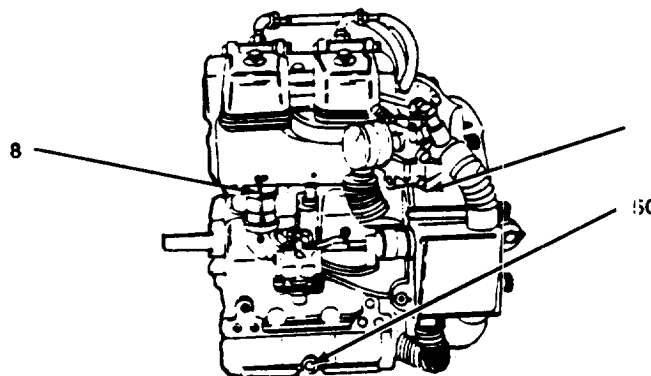

Model 2A016-3 only

OE/ Ignition Cam Wick
 HDO (Sparingly) (O)
 (See note 3)

OE/ Crankcase Drain
 HDO (Drain and refill)
 (See note 4) (O)

MODELS 2A016-3 AND 2A016-4

Table 1. Lubricant Table for 3 HP Military Standard Gasoline Engine

Temperature Range	Lubricant MIL. Symbol (NATO CODE) Specification	Capacity	Interval	Task-hour
Above + 32°F (Above 0°C)	OE/HDO 15/40 (0-1236) MIL-L-2104	*4/5 qt or (0.77L)	50 hrs	1.5
	OE/HDO 30 (0-238) MIL-L-2104	**1.8 qt or (0.1182L) ***	8 hrs 50 hrs	0.5
-10°F to +40°F (-23°C to +5°C)	OE/HDO 15/40 (0-1236) MIL-L-2104	*4/5 qt or (0.77L)	50 hrs	1.5
		1/8qt or (0.1182L) *	8 hrs	0.5
			50 hrs	
-65°F to 0°F (-50°C to -18°C)	OEA/APG-PD-1 (D-183) MIL-L-46167	*4/5 qt or (0.77L)	50 hrs	1.5
		**1/8 qt or (0.1182L)	8 hrs	0.5
*Crankcase. **Air Cleaner, -1 and -2 only. ***Oil Can Points, See note 2.				

NOTES:

1. FOR OPERATION OF EQUIPMENT IN PROTRACTED COLD TEMPERATURE. -10°F (-23°C). Remove lubricant prescribed in table 1 for temperatures above -10°F (-23°C). Clean parts with dry cleaning solvent PD-680. Relubricate with lubricants specified in table 1 for temperatures below -10°F (-23°C). For arctic operation refer to FM 9-207.
2. OIL CAN POINTS. Every 25 hours lubricate all exposed adjusting threads with OE/HDO.
3. Insure camwick is lubricated with OE/HDO (sparingly) whenever ignition contact points are replaced or adjusted.
4. CRANKCASE. Drain crankcase when hot. Every 50 hours drain and refill crankcase, operate engine for five minutes, check for leaks, check crankcase oil level and bring to full mark.

Copy of this lubrication order will remain with the equipment at all times; instructions herein are mandatory.

LO 9-2805-257-12
TO 38G2-103-2LC-1

By Order of the Secretaries of the Army and Air Force:

Official:

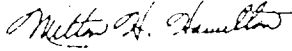

MILTON H. HAMILTON
*Administrative Assistant to the
Secretary of the Army*

00670

GORDON F. SULLIVAN
*General, United States Army
Chief of Staff*

MERRILL A. McPEAK,
*General USAF
Chief of Staff*

Official:

CHARLES C. McDONALD
*General, USAF
Commander, Air Force Logistics Command*

DISTRIBUTION:

To be distributed in accordance with DA Form 12-25E, (qty rqr block no. 4457)

★ U.S. GOVERNMENT PRINTING OFFICE : 1994 0 - 300-721 (00334)