

TM 9-2330-251-14&P

TECHNICAL MANUAL

OPERATOR'S, ORGANIZATIONAL, DIRECT SUPPORT, AND GENERAL SUPPORT MAINTENANCE MANUAL (INCLUDING REPAIR PARTS AND SPECIAL TOOLS LISTS)

FOR

TRAILER, CARGO: 1/4-TON, 2-WHEEL M416 (NSN 2330-00-706-5495) AND M416A1 (NSN 2330-01-046-2855)

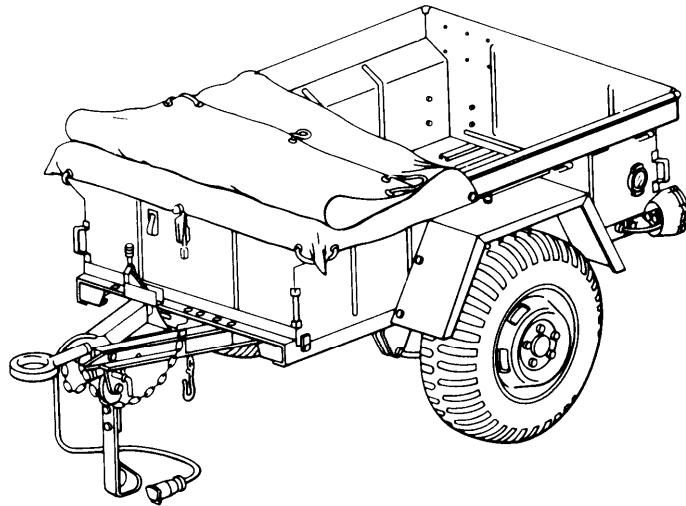

Operating Instructions	2-1
------------------------	-----

Operator/Crew PMCS	2-4
--------------------	-----

Lubrication Instructions	3-1
--------------------------	-----

Operator/Crew Troubleshooting Procedures	3-6
--	-----

Organizational PMCS	4-2
---------------------	-----

Organizational Troubleshooting Procedures	4-5
---	-----

Maintenance Allocation Chart (MAC)	B-1
------------------------------------	-----

Repair Parts and Special Tools Lists (RPSTL)	F-1
--	-----

This manual supersedes TM 9-2330-251-14&P, dated 25 October 1985.

Approved for public release; distribution is unlimited.

HEADQUARTERS, DEPARTMENT OF THE ARMY

SEPTEMBER 1990

FOR INFORMATION ON FIRST AID, REFER TO FM 21-11.

WARNING

ASBESTOS HAZARD

DO NOT handle brakeshoes, brakedrums, or other brake components unless area has been properly cleaned. There may be asbestos dust on these components which can be dangerous if you touch it or breathe it. Wear an approved filter mask and gloves. Never use compressed air or a dry brush to clean brake components. Dust may be removed using an industrial-type vacuum cleaner. Clean dust or mud away from brake components with water and a wet, soft brush or cloth. Failure to follow this warning may result in serious illness or death to personnel.

WARNING

COMPRESSED AIR

Compressed air used for cleaning or drying purposes, or for clearing restrictions, should never exceed 30 psi (207 kPa). Wear protective clothing (goggles/shield, gloves, etc.) and use caution to avoid injury to personnel.

WARNING

COUPLING AND UNCOUPLING TRAILER

All personnel must stand clear of towing vehicle and trailer during coupling and uncoupling operations. Failure to follow this warning may result in serious injury or death to personnel.

WARNING

DRY CLEANING SOLVENT

Dry cleaning solvent P-D-680 is toxic and flammable. Always wear protective goggles and gloves, and use only in a well-ventilated area. Avoid contact with skin, eyes, and clothes, and DO NOT breathe vapors. DO NOT use near open flame or excessive heat. The solvent's flash point is 100°-130°F (38°-59 °C). If you become dizzy while using cleaning solvent, immediately get fresh air and medical help. If solvent contacts eyes, immediately wash your eyes and get medical aid.

WARNING

ELECTRICAL SYSTEM

When troubleshooting an electrical malfunction or performing electrical maintenance, ALWAYS disconnect intervehicular cable from towing vehicle. Failure to do so may result in injury or death due to electric shock.

WARNING

LANDING LEG

Do not raise landing leg unless trailer is coupled to a towing vehicle or is securely supported on jackstands. Do not support weight of trailer on landing leg until landing leg is locked in the down position. Failure to follow this warning could cause trailer to fall, resulting in injury to personnel or damage to equipment.

WARNING

SECURING TRAILER

If trailer is not coupled to towing vehicle, ensure that wheels are securely chocked. Failure to do so may cause trailer to roll, resulting in injury to personnel or damage to equipment.

WARNING

USING UNAUTHORIZED CLEANING METHODS

Improper cleaning methods and use of unauthorized cleaning liquids or solvents can injure personnel and damage equipment. To prevent this, refer to TM 9-247 for further instructions.

TECHNICAL MANUAL
TM 9-2330-251-14&P

HEADQUARTERS
DEPARTMENT OF THE ARMY
Washington D.C., 4 September 1990

**OPERATOR'S, ORGANIZATIONAL, DIRECT SUPPORT,
AND GENERAL SUPPORT MAINTENANCE MANUAL
(INCLUDING REPAIR PARTS AND SPECIAL TOOLS LISTS)**

for

**TRAILER, CARGO: 1/4-TON, 2-WHEEL
M416 (NSN 2330-00-706-5495)
AND
M416A1 (NSN 2330-01-046-2855)**

Current as of 5 January 1990

REPORTING ERRORS AND RECOMMENDING IMPROVEMENTS

You can help improve this manual. If you find any mistakes or if you know of a way to improve the procedures, please let us know. Mail your letter, DA Form 2028 (Recommended *Changes to Publications and Blank Forms*), or DA Form 2028-2, located in the back of this manual, direct to: Commander, U.S. Army Tank-Automotive Command, ATTN: AMSTA-MB, Warren, MI 48397-5000. A reply will be furnished to you.

TABLE OF CONTENTS

	Page
CHAPTER 1 INTRODUCTION	
Section 1. General Information	1-1
Section II. Equipment Description	1-2
CHAPTER 2 <u>OPERATING INSTRUCTIONS</u>	
Section 1. Description and Use of Operator's Controls and Indicators	2-1
Section II. Operator/Crew Preventive Maintenance Checks and Services (PMCS)	2-4
Section III. Operation Under Usual Conditions	2-8
Section IV. Operation Under Unusual Conditions	2-11
CHAPTER 3 OPERATOR MAINTENANCE	
Section 1. Lubrication instructions	3-1
Section II. Operator/Crew Troubleshooting Procedures	3-6
Section III. Maintenance Procedures	3-9

! This manual supersedes TM 9-2330-251-14&P, dated 25 October 1985.

TABLE OF CONTENTS (Con't)

	Illus Fig	Page
CHAPTER 4 ORGANIZATIONAL MAINTENANCE		
Section I. Repair Parts; Special Tools; Test, Measurement, and Diagnostic Equipment (TMDE); and Support Equipment		4-1
Section II. Service Upon Receipt.....		4-1
Section II. <u>Organizational Preventive Maintenance Checks and Services (PMCS).</u>		4-2
Section III. <u>Organizational Troubleshooting Procedures</u>		4-5
Section V. General Maintenance Instructions		4-9
Section VI. Electrical System Maintenance		4-11
Section VII. Axle Maintenance,		4-27
Section VIII. Brake System Maintenance		4-32
Section IX. Wheels, Hubs, and Brakedrums Maintenance		4-58
Section X. Frame and Towing Attachments Maintenance		4-66
Section XI. Springs and Shock Absorbers Maintenance		4-78
Section XII. Body Maintenance.		4-85
Section XIII. Body Accessories Maintenance		4-90
Section XIV. Preparation for Storage or Shipment		4-93
CHAPTER 5 DIRECT SUPPORT AND GENERAL SUPPORT MAINTENANCE		
Section 1. Brakeshoe Maintenance		5-1
Section II. Wheels, Hubs, and Brakedrums Maintenance		5-3
Section III. Frame Maintenance		5-5
Section IV. Body Maintenance		5-5
APPENDIX A REFERENCES		A-1
APPENDIX B <u>MAINTENANCE ALLOCATION CHART</u>		B-1
APPENDIX C COMPONENTS OF END ITEM AND BASIC ISSUE ITEMS LISTS		C-1
APPENDIX D ADDITIONAL AUTHORIZATION LIST		D-1
APPENDIX E EXPENDABLE/DURABLE SUPPLIES AND MATERIALS LIST		E-1
APPENDIX F <u>REPAIR PARTS AND SPECIAL TOOLS LISTS</u>		F-1
Section 1. Introduction		F-1
Section II. Repair Parts List,		1-1
GROUP 06 ELECTRICAL SYSTEM		
0609-LIGHTS		1-1
TAILLIGHT, BLACKOUT LIGHT, AND COMPOSITE MARKER LIGHT ASSEMBLIES	1	1-1

TABLE OF CONTENTS (Con't)

	Illus Fig	Page
0613 -HULL OR CHASSIS WIRING HARNESS		2-1
INTERVEHICULAR CABLE ASSEMBLY	2	2-1
WIRING HARNESS	3	3-1
 GROUP 11 REAR AXLE		
1100-REAR AXLE ASSEMBLY.....		4-1
AXLE ASSEMBLY	4	4-1
 GROUP 12 BRAKES		
1201 - HANDBRAKES		5-1
HANDBRAKE ASSEMBLY	5	5-1
1202 -SERVICE BRAKES		6-1
BRAKESHOE AND SUPPORT ASSEMBLY, M416	6	6-1
BRAKESHOE AND SUPPORT ASSEMBLY, M416A1	7	7-1
1204 -HYDRAULIC BRAKE SYSTEM		8-1
MASTER CYLINDER AND WHEEL CYLINDER ASSEMBLY	8	8-1
HYDRAULIC BRAKE LINES, HOSES, AND FITTINGS	9	9-1
 GROUP 13 WHEELSAND TRACKS		
1311 - WHEEL ASSEMBLY		10-1
HUB AND DRUM ASSEMBLY, M416	10	10-1
HUB AND DRUM ASSEMBLY, M416A1	11	11-1
1313 -TIRES AND TUBES		12-1
TIRES AND TUBES	12	12-1
 GROUP 15 FRAME AND TOWING ATTACHMENTS		
1503 -PINTLES AND TOWING ATTACHMENTS		13-1
DRAWBAR COUPLER	13	13-1
ACTUATOR, DRAWBARS, AND ATTACHING PARTS	14	14-1
ACTUATOR ASSEMBLY	15	15-1
1507 -LANDING GEAR, LEVELING JACKS		16-1
LANDING LEG ASSEMBLY	16	16-1
 GROUP 16 SPRINGS AND SHOCK ABSORBERS		
1601-SPRINGS		17-1
SPRING ASSEMBLY	17	17-1
1604 -SHOCK ABSORBER EQUIPMENT		18-1
SHOCK ABSORBER	18	18-1
 GROUP 18 BODY		
1802 - FENDERS		19-1
FENDERS	19	19-1
1804 -DRAIN VALVES, DRAIN PLUGS, ETC.		20-1
DRAIN VALVE ASSEMBLY	20	20-1
1810 - CARGO BODY		21-1
BODY	21	21-1

TABLE OF CONTENTS (Con't)

	Illus Fig	Page
GROUP22 BODY ACCESSORY ITEMS		
2202 - ACCESSORY ITEMS		
REFLECTORS		22-1
2210 -DATA PLATES	22	22-1
DATA PLATES		23-1
	23	23-1
GROUP95 GENERAL USE STANDARDIZED PARTS		
9501 - BULK MATERIEL		
BULK MATERIEL		BULK-1
	BULK	BULK-1
Section III, Special Tools List (Not Applicable)		
Section IV. Cross-reference Indexes		
NATIONAL STOCK NUMBER INDEX		I-1
PART NUMBER INDEX		I-4
FIGURE AND ITEM NUMBER INDEX		1-11
APPENDIX G ILLUSTRATED LIST OF MANUFACTURED ITEMS		G-1
APPENDIX H TORQUE LIMITS		H-1
INDEX		Index 1

CHAPTER 1 INTRODUCTION

Section 1. GENERAL INFORMATION

Paragraph Title	Page Number
Destruction of Army Materiel to Prevent Enemy Use	1-1
Maintenance Forms, Records, and Reports	1-1
Preparation for Storage or Shipment	1-1
Reporting Equipment Improvement Recommendations (EIRs)	1-1
Scope	1-1

1-1. SCOPE.

- a. Type of Manual. Operator's, Organizational, Direct Support, and General Support Maintenance Manual (Including Repair Parts and Special Tools Lists).
- b. Equipment Name and Model Numbers. Trailer, Cargo: ¼-Ton, 2-Wheel, M416 and M416A1.
- c. Purpose of Equipment. Used to carry a maximum load of 500 lb (227 kg) both cross-country and highway.

1-2. MAINTENANCE FORMS, RECORDS, AND REPORTS.

Department of the Army forms and procedures used for equipment maintenance will be those prescribed by DA Pam 738-750, *The Army Maintenance Management System (TAMMS)*.

1-3. DESTRUCTION OF ARMY MATERIEL TO PREVENT ENEMY USE.

For destruction of Army materiel to prevent enemy use, refer to TM 750-244-6.

1-4. PREPARATION FOR STORAGE OR SHIPMENT.

For information on preparing the trailers for storage or shipment, refer to Chapter 4, Section XIV.

1-5. REPORTING EQUIPMENT IMPROVEMENT RECOMMENDATIONS (EIRs).

If your trailer needs improvement, let us know. Send us an EIR. You, the user, are the only one who can tell us what you don't like about your equipment. Let us know why you don't like the design or performance. Put it on an SF 368 (*Quality Deficiency Report*). Mail it to us at: Commander, U.S. Army Tank-Automotive Command, ATTN: AMSTA-MP, Warren, MI 48397-5000. We'll send you a reply.

Section II. EQUIPMENT DESCRIPTION

Paragraph Title	Page Number
Differences Between Models.....	1-6
Equipment Characteristics, Capabilities, and Features	1-2
Equipment Data	1-7
Location and Contents of Plates	1-6
Location and Description of Major Components	1-3

1-6. EQUIPMENT CHARACTERISTICS, CAPABILITIES, AND FEATURES.

a. Characteristics.

- (1) Watertight body will float the trailer and payload during fording.
- (2) Two drain valves, one in the left front and one in the right rear of floor, allow water to be drained from the trailer cargo body.
- (3) Two-wheel single axle with multi-leaf spring suspension.
- (4) Retractable landing leg supports front of the trailer when uncoupled from the towing vehicle,
- (5) Manually operated parking brake.
- (6) Operates on 24-volt electrical system.
- (7) Automatic emergency braking if M416A1 trailer breaks away from the towing vehicle,

b. Capabilities and Features.

- (1) Maximum payload (cross-country and highway): 500 lb (227 kg).
- (2) Angle of departure: 20°.
- (3) Towing vehicle: ¼- or ¾-ton utility truck.
- (4) Towing speeds (maximum):
 - (a) Highway: 55 mi/h (88 km/h)
 - (b) Improved roads: 50mi/h (80 km/h)
 - (c) Cross-country: 30mi/h (48 km/h)

1-7. LOCATION AND DESCRIPTION OF MAJOR COMPONENTS,

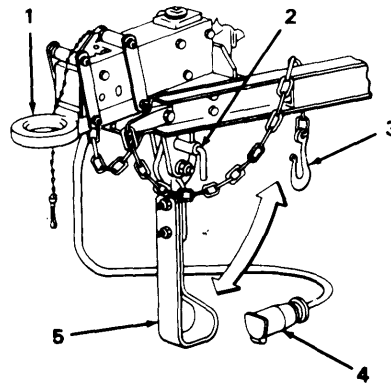

Key	Component	Description
1	Drawbar Coupler	Connects to the towing vehicle pintle hook.
2	Lockpin	Locks the landing leg in up or down position.
3	Safety Chains	Hook to eyebolts on the towing vehicle to prevent the trailer from fully breaking away.
4	Intervehicular Cable	Provides connection between the towing vehicle and trailer electrical system.
5	Landing Leg	Supports front of trailer when not coupled to the towing vehicle.

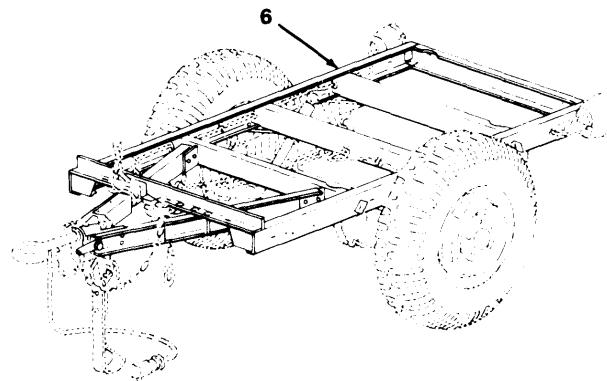

Key	Component	Description
6	Frame	Welded assembly made of two pressed-steel siderails, reinforced by four pressed-steel crossmembers.

TA503882

1-7. LOCATION AND DESCRIPTION OF MAJOR COMPONENTS (Con't).

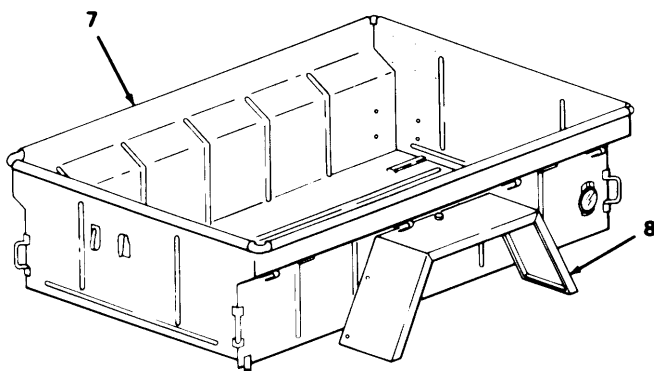

Key	Component	Description
7	Cargo Body	Watertight, one-piece welded assembly. Allows the trailer and load to float during fording operations.
8	Fender	Protects personnel, cargo, and towing vehicle from mud, rocks, and debris that may be thrown from the trailer tires during operation.

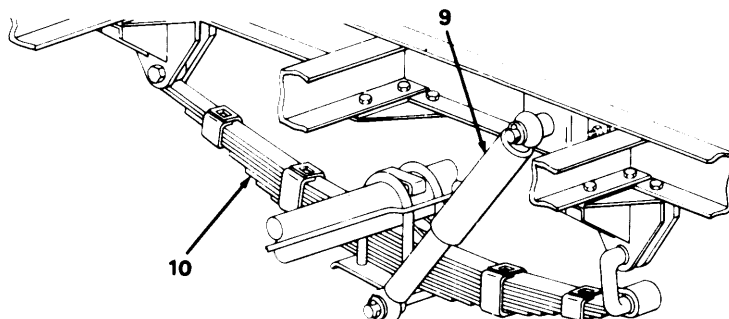

Key	Component	Description
9	Shock Absorbers	Support weight of the trailer and cushion road shock.
10	Springs	Multi-leaf construction support weight of the trailer.

1-7, LOCATION AND DESCRIPTION OF MAJOR COMPONENTS (Con't).

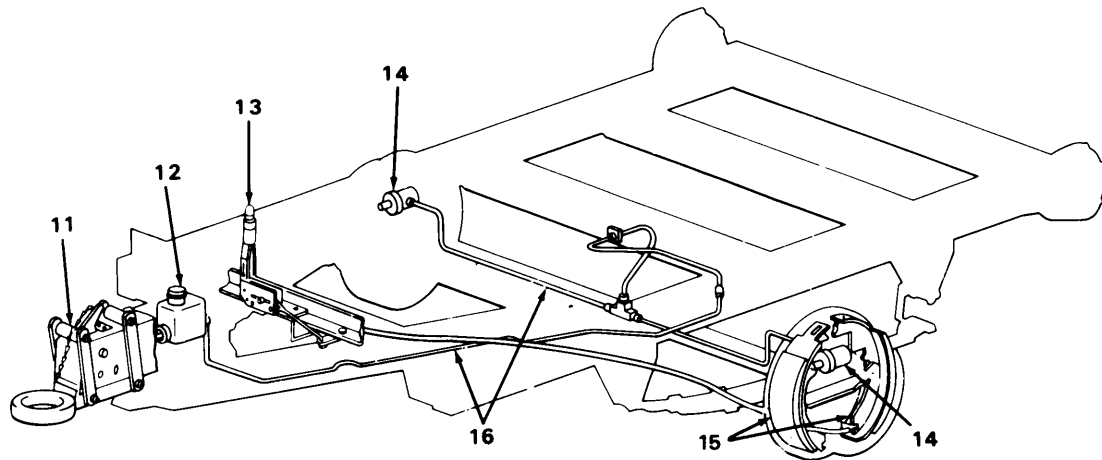

Key	Component	Description
11	Brake Actuator (M416A1)	Transfers mechanical braking force from the towing vehicle to the master cylinder.
12	Master Cylinder (M416A1)	Converts mechanical motion of the brake actuator to hydraulic pressure.
13	Handbrake Lever	Applies mechanical pressure to the brakeshoes. Brakeshoes apply pressure to the brakedrums, preventing movement of the trailer while parked.
14	Wheel Cylinders (M416A1)	Convert hydraulic pressure to mechanical motion, activating the service brakes.
15	Brakeshoes	Apply pressure to the brakedrums, slowing and stopping the trailer.
16	Hydraulic Brake Lines (M416A1)	Transfer hydraulic pressure from the master cylinder to the wheel cylinders.

1A503884

1-7. LOCATION AND DESCRIPTION OF MAJOR COMPONENTS (Con't).

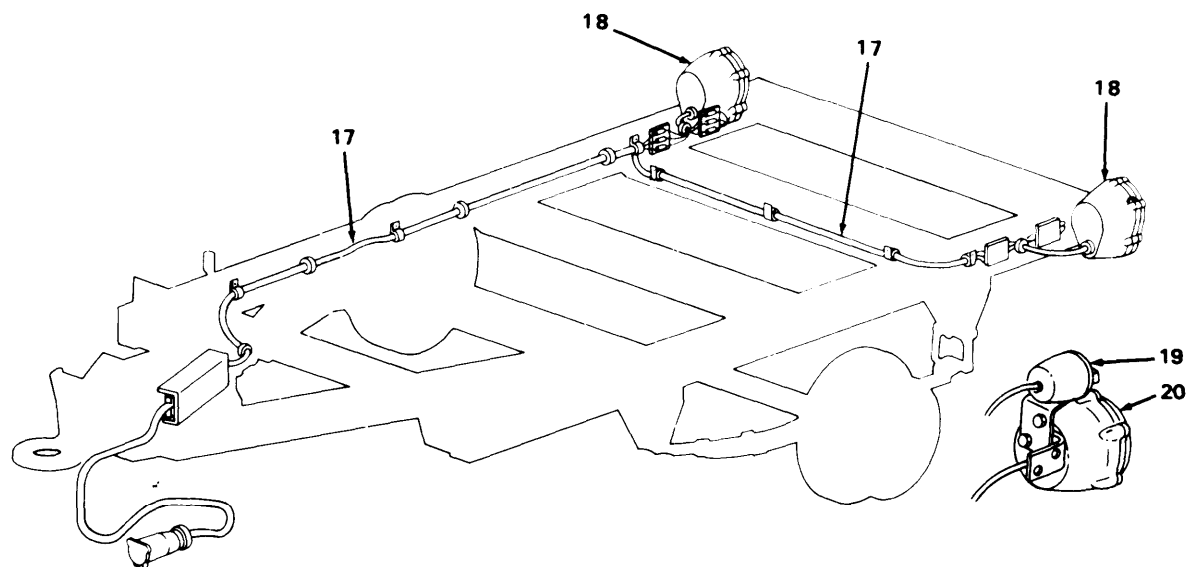

Key	Component	Description
17	Chassis Wiring Harness	Carries electrical current to the trailer light assemblies.
18	Composite Light Assemblies (M416A1)	Provide stoplights, taillights, turn signal lights, and blackout stoplights all in one light assembly.
19	Blackout Stoplight (M416)	Provides a blackout stoplight.
20	Stoplight Taillight (M416)	Provides stoplights, taillights, and turn signal lights.

1-8. DIFFERENCES BETWEEN MODELS,

- a. The main difference between the M416 and the M416A1 Cargo Trailers is the brake system.
- b. The M416 Cargo Trailer only has a handbrake system.
- c. The M416A1 Cargo Trailer, in addition to the handbrake system, also has an inertia-actuated hydraulic brake system.

1-90 LOCATION AND CONTENTS OF PLATES.

The identification plate located on the right front framerrail supplies information for chassis procurement. The identification plate located on the upper right rear corner of the body provides trailer weights, dimensions, and payload information. The chassis identification plate provides information for the M569 Chassis, which is a component of the M416.

TA503885

1-9. LOCATION AND CONTENTS OF PLATES (Con't)

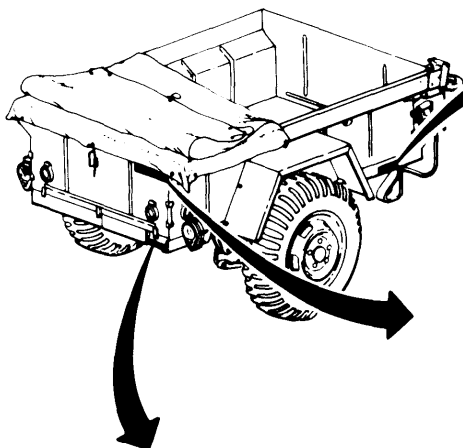

RESPONSIBLE AGENCY	PROCUREMENT	DEPOT MAINTENANCE
CHASSIS BODY	000000	000000
MTD. EQPT	000000	000000
U.S. PROPERTY		

TRAILER CARGO: 1/4 TON 2 WHL M416A1 NSN 2330-01-046-2855 MFD BY _____ VEH IDENT NO _____ CONTRACT NO _____		WEIGHT AND DIMENSION DATA 	
PUBLICATION TM 9-2330-251-14&P DELIVERY DATE _____ INSPECTED _____ SHIPPING CUBAGE 159 CU. FT			
WEIGHTS EMPTY CROSSCOUNTRY HIGHWAY			
PAYLOAD	540	500	500
WHEELS	130	1022	1022
LDG LEG	130	148	148
TOTAL	670	1170	1170

TRAILER CHASSIS 1/4 TON 2 WHL M569A1 NSN 2330-01-044-1971 MFD BY _____ VEH IDENT NO _____ CONTRACT NO _____ SHIPPING CUBAGE 115 CU. FT	WEIGHT AND DIMENSION DATA - TRAILER CHASSIS 	CROSS HIGH WEIGHTS EMPTY COUNTRY WAY												
DELIVERY DATE _____ INSPECTED _____ PUBLICATION TECH MANUAL TM 9 2330 251 14&P	<table border="1"> <tr> <td>PAYLOAD</td> <td>640</td> <td>890</td> </tr> <tr> <td>WHEELS</td> <td>408</td> <td>1018</td> </tr> <tr> <td>LDG LEG</td> <td>122</td> <td>152</td> </tr> <tr> <td>TOTAL</td> <td>530</td> <td>1170</td> </tr> </table>		PAYLOAD	640	890	WHEELS	408	1018	LDG LEG	122	152	TOTAL	530	1170
PAYLOAD	640	890												
WHEELS	408	1018												
LDG LEG	122	152												
TOTAL	530	1170												

NOTE: M569A1 CHASSIS ISA COMPONENT OF M416 SERIES TRAILERS.

1-10. EQUIPMENT DATA.

Weights and Dimensions:	
Length (overall).....	108.5 (275.6 cm)
Width (overall).....	60.5 (153.7 cm)
Height (overall).....	42 in. (106.7 cm)
Drawbar Coupler Height:	
M416 (adjustable)	23 in. or 26 in. (58.4 cm or 66.0 cm)
M416A1	26 in. (66.0 cm)
Weight (empty)	670 lb (304 kg)
Tires:	
Number	2
Number of Plies.....	6
Size.....	7.00 x 16
Inflation:	
Cross-country	22 psi (152 kPa)
Highway	25 psi (172 kPa)
Mud, Snow, and Sand	18 psi (124 kPa)
Type	Military Pneumatic

TA509006

1-10. EQUIPMENT DATA (Con't).

Wheels:	
Number	2
Diameter of Stud Circle	5,5 in. (14,0 cm)
Number of Studs	5
Rim Size	16 x 4.50
Material:	
M416	Magnesium Alloy
M416A1	Steel
Cargo Body:	
Length	72 in. (182.9 cm)
Width	41 in. (104.1 cm)
Height	18 in. (45,7 cm)
Springs:	
Type	Semielliptical
Shock Absorbers:	
Type	Nonadjustable, Nonrefillable
Handbrake:	
Type	Expanding Shoe
Control	Hand
Actuation	Mechanical
Service Brake (M416A1):	
Control	Inertia Actuator
Actuation	Hydraulic
Axle:	
M416:	
Length	58.75 in. (149.2 cm)
Type	Tubular
Diameter	2.28 in. (6.6 cm)
Spindle	1.59 in. (4.1 cm)
M416A1 :	
Length	61.62 in. (156.5 cm)
Type	Tubular
Diameter	2.28 in. (5.8 cm)
Spindle:	
inner,	1.06 in. (2.7 cm)
Outer	1.38 in. (3.5 cm)

1-10. EQUIPMENT DATA (Con't).

Center of Gravity (forward of rear axle):	
M416:	
Empty	23 in. (58.4 cm)
Loaded	41.5 in. (105.4 cm)
M416A1:	
Empty	9 in. (22.9 cm)
Loaded:	
Cross-country	5.81 in. (14.8 cm)
Highway	5.12 in. (13.0 cm)
Electrical System	24-Volt

CHAPTER 2 OPERATING INSTRUCTIONS

Section 1. DESCRIPTION AND USE OF OPERATOR'S CONTROLS AND INDICATORS

Paragraph Title	Page Number
Controls and indicators	2-1
Introduction.....	2-1

2-1. INTRODUCTION.

This section shows the location and function of all M416 and M416A1 Cargo Trailer controls and indicators. Review this section thoroughly before operating the trailers.

2-2. CONTROLS AND INDICATORS.

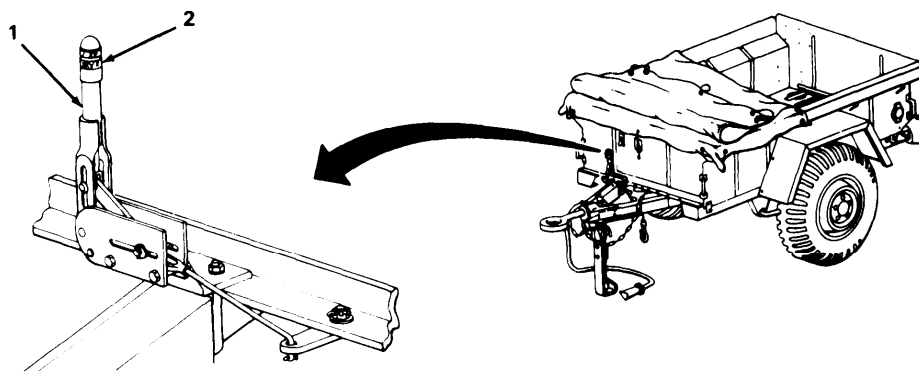

Key	Control or Indicator	Description
1	Handbrake Lever	Applies the handbrake.
2	Adjustment Knob	Adjusts handbrake cable tension.

TA503887

2-2. CONTROLS AND INDICATORS (Con't).

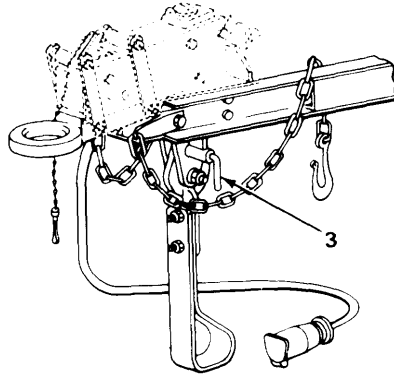

Key	Control or Indicator	Description
3	Lockpin	Secures the landing leg in up or down position.

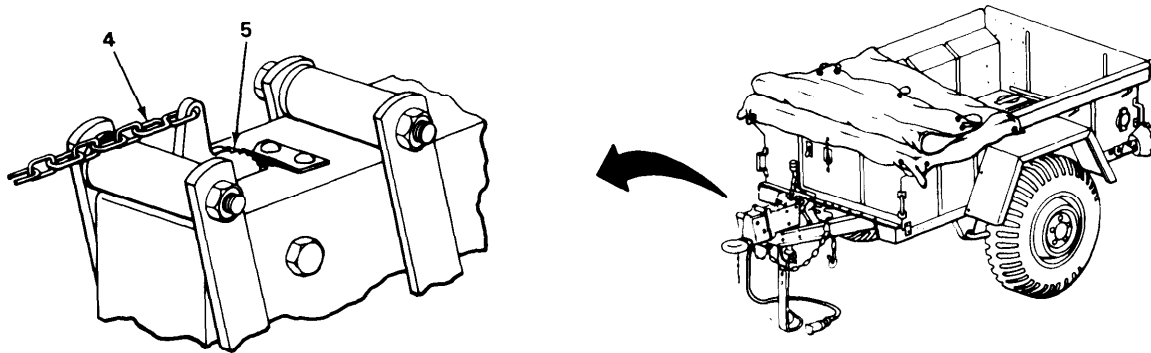

Key	Control or Indicator	Description
4	Breakaway Chain (M416A1)	Actuates the breakaway lever,
5	Breakaway Lever (M416A1)	Applies the trailer brakes if towing vehicle and trailer separate,

TA503888

2-2. CONTROLS AND INDICATORS (Con't).

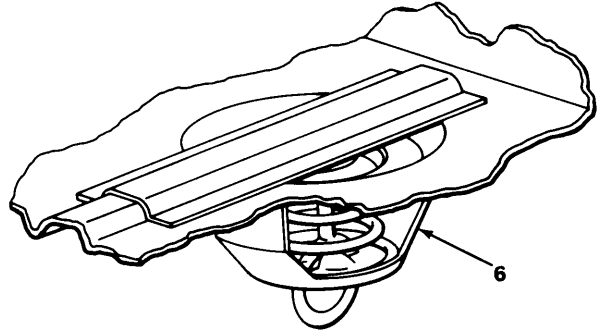
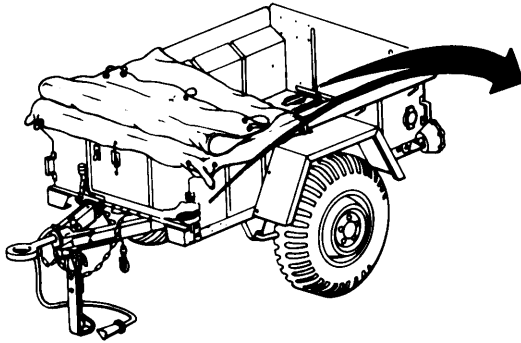

Key	Control or Indicator	Description
6	Drain Valves	Used to drain any accumulation of water from the cargo body.

Section II. OPERATOR/CREW PREVENTIVE MAINTENANCE CHECKS AND SERVICES (PMCS)

Paragraph Title	Page Number
General	2-4
Maintenance Forms and Records	2-4
Operator/Crew Preventive Maintenance Checks and Services (PMCS), Table 2-1	2-6
PMCS Procedures.....	2-4

2-3. GENERAL.

Preventive maintenance is detecting/correcting problems before they happen, or fixing minor problems before they become major problems. Table 2-1 contains a list of preventive maintenance checks and services to be performed by the operator/crew. Attention to these checks and services will increase the useful life of the equipment. Every possible problem cannot be covered in the PMCS. Be alert for anything that might cause a problem.

2-4. MAINTENANCE FORMS AND RECORDS.

Every mission begins and ends with paperwork. There is not much of it, but you have to keep it up. The forms and records you fill out have several uses. They are a permanent record of the service, repairs, and modifications made on your trailer. They are reports to organizational maintenance and to your commander. They are a check list for you when you want to know what is wrong with the trailer after its last use, and whether those faults have been fixed. For the information you need on forms and records, refer to DA Pam 738-750.

2-5. PMCS PROCEDURES.

- a. While performing your PMCS, pay attention to all WARNINGS and CAUTIONS.
- b. Table 2-1 lists the inspections and services required to keep the trailer in good operating condition. Perform these inspections and services at the following intervals:
 - (1) Perform *Before* (B) PMCS before operating the trailer.
 - (2) Perform *During* (D) PMCS while operating the trailer.
 - (3) Perform *After* (A) PMCS right after operating the trailer,
- c. If something doesn't work, troubleshoot it with the instructions in this manual and notify your supervisor.
- d. Always do your PMCS in the same order so it gets to be a habit. Once you've had some practice, you'll spot anything wrong in a hurry,
- e. If anything looks wrong and you can't fix it, write it on DA Form 2404. If you find something seriously wrong, IMMEDIATELY report it to organizational maintenance.
- f. When you perform PMCS, take along the tools you need to make all the checks. You'll always need a clean rag (Item 9, Appendix E) or two,

2-5. PMCS PROCEDURES (Con't).

WARNING

Dry cleaning solvent P-D-680 is toxic and flammable. Always wear protective goggles and gloves, and use only in a well-ventilated area. Avoid contact with skin, eyes, and clothes, and DO NOT breathe vapors. DO NOT use near open flame or excessive heat. The solvent's flash point is 100°-130°F (38°-59°C). If you become dizzy while using cleaning solvent, immediately get fresh air and medical help. If solvent contacts eyes, immediately wash your eyes and get medical aid.

(1) Keep It Clean. Dirt, grease, oil, and debris get in the way and may cover up a serious problem. Clean as you work and as needed. Use dry cleaning solvent (Item 10, Appendix E) on all metal surfaces. Use soap (Item 4, Appendix E) and water when you clean rubber or plastic.

(2) Bolts, Nuts, and Screws'. Check them all for obvious looseness, missing, bent, or broken condition. You can't try them all with a tool, of course, but look for chipped paint, bare metal, or rust around bolt heads. If you find one you think is loose, tighten it or report it to organizational maintenance if you can't tighten it,

(3) Welds. Look for loose or chipped paint, rust, or gaps where parts are welded together. If you find a bad weld, report it to organizational maintenance.

(4) Electric Wires and Connectors. Look for cracked or broken insulation, bare wires, and loose or broken connectors. Tighten loose connectors and make sure the wires are in good condition.

NOTE

Items 5 and 6 are for M416A1 only.

(5) Hydraulic Hoses and Lines. Look for wear, damage, and signs of leaks. Ensure that clamps and fittings are tight. Wet spots indicate leaks, of course, but a stain around a fitting or connector can also mean a leak. If a leak comes from a loose fitting or connector, tighten it. If something is broken or worn out, report it to organizational maintenance.

(6) Fluid Leakage. It is necessary for you to know how fluid leakage affects the status of your trailer. The following are definitions of the types/classes of leakage you need to know to be able to determine the status of your trailer. Learn and be familiar with them, and remember — when in doubt, notify your supervisor!

Leakage Definitions for Operator/Crew PMCS

Class I	Seepage of fluid (as indicated by wetness or discoloration) not great enough to form drops.
Class II	Leakage of fluid great enough to form drops, but not enough to cause drops to drip from the item being inspected.
Class III	Leakage of fluid great enough to form drops that fall from the item being inspected.

CAUTION

When operating with Class I or II leaks, continue to check fluid levels in addition to that required in PMCS. Parts without fluid will stop working or may be damaged.

- (a) Equipment operation is allowed with minor leakage (Class I or II). The fluid level in an item/system affected by such leakage must be checked more frequently than required in PMCS. When in doubt, notify your supervisor.
- (b) IMMEDIATELY report Class III leaks to organizational maintenance.

2-5. PMCS PROCEDURES (Con't).

g. The columns in Table 2-1 are defined as follows:

(1) **Item No.** The number in this column shall be used as a source of item numbers for the "TM ITEM NO. " column on DA Form 2404 in recording results of PMCS.

(2) **Interval.** Tells you when to do a certain check or service.

(3) **Item To Be Inspected.** Lists system and common names of items that are to be inspected, Included in this column are specific servicing, inspection, replacement, or adjustment procedures to be followed. Carefully follow these instructions. If you do not have the tools, or if the procedure tells you to, have organizational maintenance do the work.

(4) **Equipment Is Not Ready/Available If.** This column tells you when and why the trailer cannot be used.

NOTE

The terms "ready/available" and "mission-capable" refer to the same status: Trailer is on hand and is able to perform its combat missions (AR 700-1 38).

Table 2-1. Operator/Crew Preventive Maintenance Checks and Services (PMCS).

B - Before

D - During

A - After

ITEM NO.	INTERVAL			ITEM TO BE INSPECTED PROCEDURE: Check for and have repaired, filled or adjusted as needed.	Equipment is Not Ready/Available If:
	B	D	A		
1	• /		●	TIRES a. Check tires for obvious damage such as cuts, bruises, and bulges. b. Check for apparent air leakage. c. Remove any glass, nails, or stones. d. Check tire pressure. Proper pressure is: I Cross-country 22 psi (152 kPa) . Highway 25 psi (172 kPa) . Mud, snow, and sand 18 psi (124 kPa)	Tires damaged or unserviceable.
2	●			WHEELS Check for missing or obviously loose wheel nuts.	Two or more wheel nuts loose or missing.
3	●			MASTER CYLINDER, HYDRAULIC LINES, AND BACKING PLATES (M416A1) Check for any evidence of brake fluid leaks at master cylinder, hydraulic lines, and backing plates. Leaks at backing plates indicate leaking wheel cylinders.	Class III leaks evident.

2-5. PMCS PROCEDURES (Con't).

Table 2-1. Operator/Crew Preventive Maintenance Checks and Services (PMCS) (Con't).

ITEM NO.	INTERVAL			ITEM TO BE INSPECTED PROCEDURE: Check for and have repaired, filled or adjusted as needed.	Equipment Is Not Ready/Available If:
	B	D	A		
4	•	•		DRAWBAR COUPLER, INTERVEHICULAR CABLE, AND SAFETY CHAINS Check for obvious looseness and for condition of drawbar coupler, intervehicular cable, and safety chains.	Drawbar coupler cracked or broken. Safety chains missing or broken.
5	•			LANDING LEG Check for obvious looseness of mounting bolts and condition of landing leg.	Evidence or indication landing leg might collapse.
6	•			HANDBRAKES a. Check for proper operation of handbrakes. b. Adjust handbrake lever if no resistance is needed to move handbrake lever past halfway point of travel (para 3-6).	
7	•			FRAME AND SUSPENSION Check frame and suspension for damage.	Spring is broken, shock absorber leaking or missing, or frame is cracked.
8	•			LIGHTS AND REFLECTORS a. Check lights and reflectors for obvious damage and broken lens. b. Check lights for proper operation.	
9		•		BRAKES (M416A1) Check brakes for grabbing or pulling.	Brakes pull or grab.

Section III. OPERATION UNDER USUAL CONDITIONS

Paragraph Title	Page Number
Coupling Trailer to Towing Vehicle	2-8
Towing Instructions	2-9
Uncoupling Trailer from Towing Vehicle,	2-10

2-6. COUPLING TRAILER TO TOWING VEHICLE.

WARNING

All personnel must stand clear of towing vehicle and trailer during coupling operation. Failure to follow this warning may result in serious injury or death to personnel.

- a. Prepare towing vehicle for coupling and operation in accordance with applicable technical manual,
- b. Perform all trailer operator/crew *Before* (B) PMCS.
- c. Ensure that trailer handbrake lever (1) is applied.

NOTE

Have assistant direct you while backing towing vehicle to trailer,

- d. Slowly back towing vehicle until pintle (4) is adjacent to drawbar coupler (8),
- e. Remove pintle lockpin (9) and open pintle (4).
- f. Release trailer handbrake lever (1) and move trailer as required to engage drawbar coupler (8) in pintle (4).

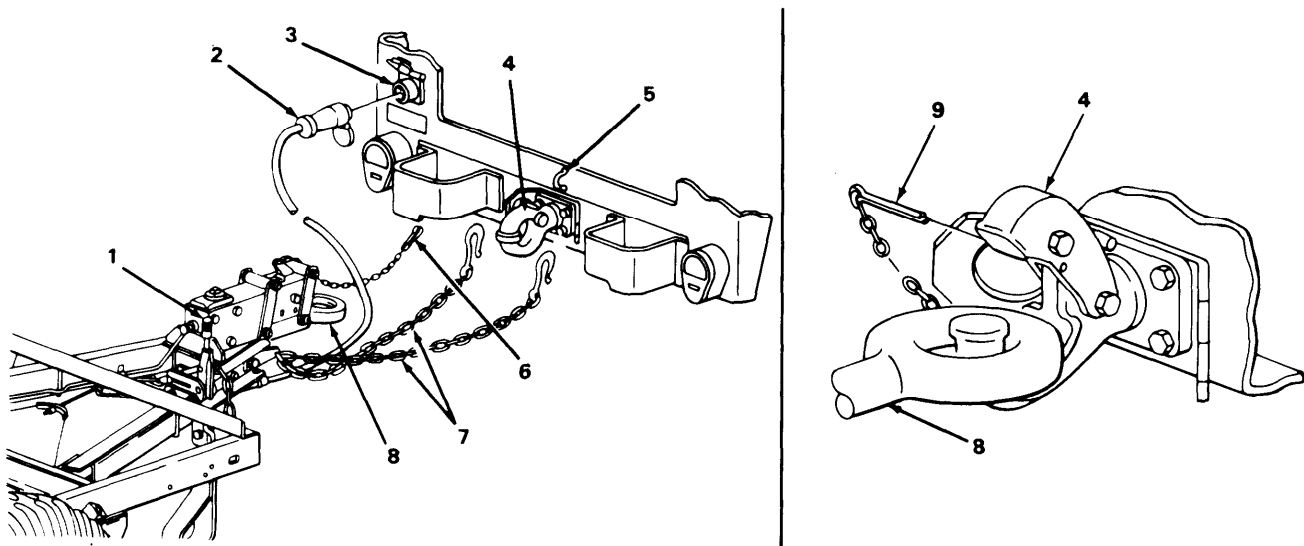

TA503890

2-6. COUPLING TRAILER TO TOWING VEHICLE (Con't).

- g. Close pintle (4) and install pintle lockpin (9).
- h. Attach safety chains (7) from trailer to towing vehicle by crossing them under drawbar coupler (8) to opposite side eyebolts on towing vehicle.

NOTE

Step i applies to M416A1 only.

- i. Connect breakaway chain (6) to footman loop (5) at rear of towing vehicle.
- j. Connect intervehicular cable (2) to receptacle (3) on towing vehicle.

WARNING

Do not raise landing leg (11) unless trailer is coupled to towing vehicle. Failure to follow this warning could cause trailer to fall, resulting in injury to personnel or damage to equipment.

- k. Pull lockpin (1 O) on landing leg (11) outward.
- l. Rotate landing leg (11) upward and lock it in position by pushing lockpin (10) inward and turning lockpin handle down.

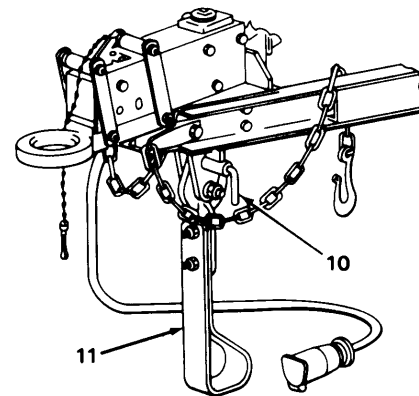

2-7. TOWING INSTRUCTIONS.

NOTE

Refer to FM 21-305 for further information on safe driving practices.

- a. **General.** Perform operator/crew *During* (D) PMCS while operating the trailer.
- b. **Driving.** Keep in mind the overall length of the towing vehicle and trailer when passing other vehicles, turning, and backing.
- c. **Turning.** When turning corners, remember that the trailer wheels turn inside the turning radius of the towing vehicle. Make a right turn by driving the towing vehicle approximately halfway into the intersection and then cutting sharply to the right. This will keep trailer wheels off the curb. Keep the vehicle close enough to the edge of the road to prevent following vehicles from attempting to pass on the right.
- d. **Stopping.** During normal operation stepping on the brake pedal will stop both the towing vehicle and trailer. Apply brakes gradually and smoothly.

TA503891

2-7. TOWING INSTRUCTIONS(Con't).

e. **Parking.** When parking for extended periods, both the towing vehicle and trailer parking brakes should be applied.

f. **Backing.**

(1) Have an assistant guide you while backing. Adjust rearview mirrors before backing.

(2) When the towing vehicle and the trailer are in a straight line, the rear of the trailer will move opposite to the direction the front towing vehicle wheels are turned. When the towing vehicle wheels are turned to the right, the rear of the trailer will move to the left. When the towing vehicle wheels are turned to the left, the rear of the trailer will move to the right.

(3) To decrease the angle of turn, gradually turn towing vehicle wheels in the direction the trailer is turning. This will gradually decrease the angle until the towing vehicle and trailer are in a straight line.

2-8. UNCOUPLING TRAILER FROM TOWING VEHICLE.

WARNING

All personnel must stand clear of towing vehicle and trailer during coupling operation. Failure to follow this warning may result in serious injury or death to personnel.

- a. Pull lockpin (1) on landing leg (2) outward.

WARNING

Ensure that landing leg (2) is locked in the down position before continuing with uncoupling operation. Failure to follow this warning could cause trailer to fall, resulting in injury to personnel or damage to equipment.

- b. Rotate landing leg (2) down and lock it in position with lockpin (1).
 c. Disconnect intervehicular cable (4) from receptacle (5) on towing vehicle.

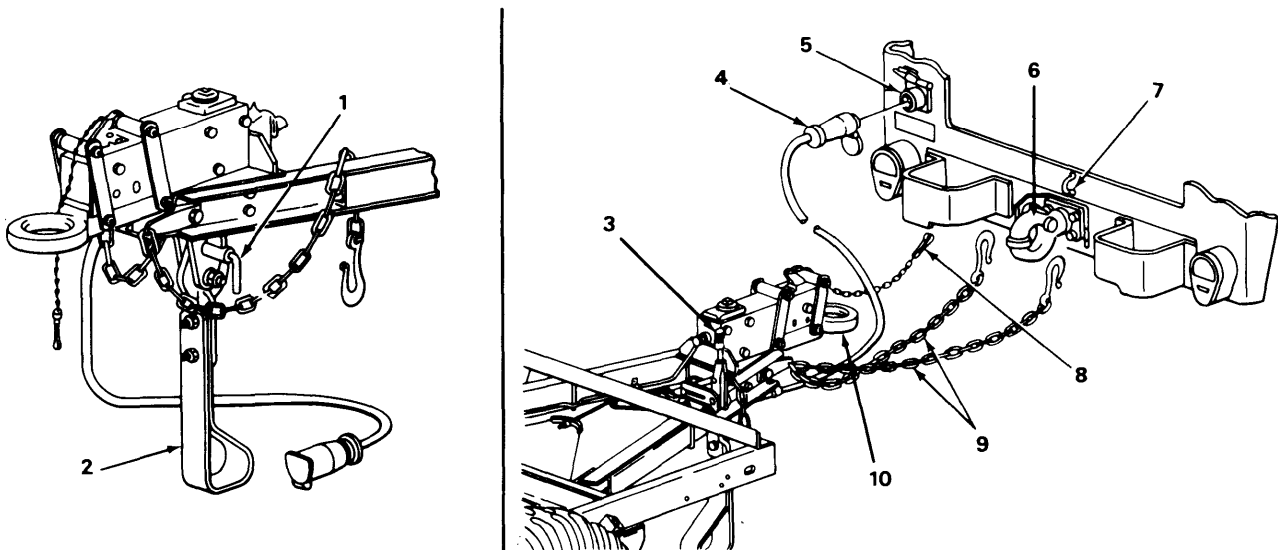

TA503892

2-8. UNCOUPLING TRAILER FROM TOWING VEHICLE (Con't).

NOTE

Step d applies to M416A1 only.

- d. Disconnect breakaway chain (8) from footman loop (7) at rear of towing vehicle.
- e. Unhook safety chains (9) from towing vehicle and stow on trailer.
- f. Remove pintle lockpin (11) and open pintle (6).
- g. Lift trailer to uncouple drawbar coupler (1 O) from pintle (6) and set trailer down on landing leg (2).
- h. Apply trailer handbrake lever (3).
- i. Close pintle (6) and install pintle lockpin (11).
- j. Perform operator/crew *After* (A) PMCS.

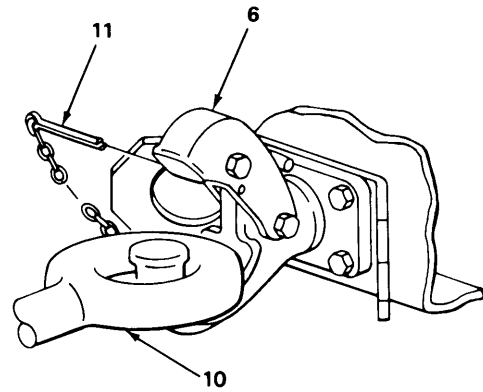

Section IV. OPERATION UNDER UNUSUAL CONDITIONS

Paragraph Title	Page Number
Fording	2-12
Operation in Extreme Cold	2-11
Operation in Extreme Heat	2-12
Operation in Mud	2-12
Operation in Saltwater Areas	2-12
Operation in Sandy or Dusty Areas	2-12
Operation in Snow	2-12

2-9. OPERATION IN EXTREME COLD.

- a. Refer to Chapter 3, Section I for proper lubricants to use in extreme cold.
- b. Extreme cold can cause insulation material on electrical wire to crack and cause short circuits. Other materials may become hard, brittle, and easily damaged or broken.
- c. Ensure that tires are properly inflated (para 1-10). Tires may freeze to the ground or have flat spots if underinflated.

TA503893

2-9. OPERATION IN EXTREME COLD (Con't).

- d. Brakeshoes may freeze to brakedrum and will need to be heated to prevent damage (FM 9-207).
- e. When parking short term, park in a sheltered area out of the wind. When parking long term, place a footing of planks or brush under the wheels and landing leg.
- f. Remove all built-up snow or ice as soon as possible after operation.
- g. If available, use canvas covers to shield the trailer. Keep cover ends off the ground to keep them from freezing to the ground.

2-10. OPERATION IN EXTREME HEAT.

- a. Refer to Chapter 3, Section I for proper lubricants to use in extreme heat.
- b. Do not park the trailer in sunlight for long periods of time, Heat and sunlight shorten tire life, If available, use canvas covers to shield the trailer,

2-11, OPERATION IN SANDY OR DUSTY AREAS.

- a. Clean, inspect, and lubricate more often in sandy or dusty areas (Chapter 3, Section i),
- b. Reduce tire pressure for emergency use on beach or desert sand. Return tire pressure to normal after emergency operation (para 1-10).

2-12. OPERATION IN SALTWATER AREAS.

Saltwater causes rapid rust and corrosion to develop, Clean, inspect, and lubricate as soon as possible after operation in saltwater area. Have organizational maintenance pack wheel bearings contaminated by saltwater as soon as possible (Chapter 3, Section 1).

2-13. OPERATION IN SNOW.

Refer to FM 21-305 for special instructions on operating in snow,

2-14, OPERATION IN MUD.

Thoroughly clean, inspect, and lubricate as soon as possible after operation in mud, Have organizational maintenance pack wheel bearings contaminated by mud as soon as possible (Chapter 3, Section 1),

2-15. FORDING.

- a. Check bottom surface of stream or river. Do not ford if bottom surface is too soft.
- b. After fording, apply the brakes a few times to help dry the brake linings. Ensure that the brakes are operating properly before driving at normal speeds.
- c. Lubricate all unpainted surfaces with lubricating oil, Lubricate the trailer in accordance with instructions in Chapter 3, Section 1,
- d. Refer to TM 9-238 for deepwater fording information,

CHAPTER 3 OPERATOR MAINTENANCE

Section 1. LUBRICATION INSTRUCTIONS

Paragraph Title	Page Number
General	3-1
Lubrication Chart	3-3
Lubrication Instructions Under Unusual Conditions	3-2
Specific Lubrication Instructions	3-1

3-1. GENERAL.

NOTE

These instructions are MANDATORY.

- a. The M416 and M416A1 Cargo Trailers must receive lubrication with approved lubricants at recommended intervals in order to be mission-ready at all times.
- b. The KEY lists lubricants to be used in all temperature ranges and shows the intervals.
- c. The Lubrication chart shows lubrication points, names items to relubricated, the required lubricant, and the recommended interval for lubrication. Any special lubricating instructions required for specific components are contained in the "NOTES" section of the chart.
- d. Recommended intervals are based on normal conditions of operation, temperature, and humidity. When operating under extreme conditions, lubricants should always be changed more frequently. When in doubt, notify your supervisor.

3-2. SPECIFIC LUBRICATION INSTRUCTIONS.

- a. Maintain a record of lubrication performed and report any problems noted during lubrication. Refer to DA Pam 738-750 for applicable forms and procedures.

WARNING

Dry cleaning solvent P-D-680 is toxic and flammable. Always wear protective goggles and gloves, and use only in a well-ventilated area. Avoid contact with skin, eyes, and clothes, and DO NOT breathe vapors. DO NOT use near open flame or excessive heat. The solvent's flash point is 100°F-130°F (38°C-59°C). If you become dizzy while using cleaning solvent, immediately get fresh air and medical help. If solvent contacts eyes, immediately wash your eyes and get medical aid.

- b. Use dry cleaning solvent (Item 10, Appendix E) to clean grease fittings, lubrication points, and surrounding areas before lubricating.
- c. When lubricating at a grease fitting, apply enough grease to purge old grease from the lubricated area. When old grease oozes from the grease fitting, purging and lubrication are adequate.

3-2. SPECIFIC LUBRICATION INSTRUCTIONS (Con't).

WARNING

Wipe excess lubricant from the area of brakeshoe linings to avoid grease soaking the linings. If brakeshoe linings become soaked, have organizational maintenance replace them. Failure to follow this warning may cause brakes to malfunction, resulting in serious injury or death to personnel.

- d. After lubrication, wipe off excess oil or grease to prevent accumulation of foreign matter.

3-3. LUBRICATION INSTRUCTIONS UNDER UNUSUAL CONDITIONS.

a. Lubricate more frequently to compensate for abnormal or extreme conditions such as high or low temperatures, prolonged periods of high-speed operation, continued operation in sand or dust, immersion in water, or other exposure to moisture. Any one of these conditions may cause contamination and quickly destroy the protective qualities of lubricants.

- b. Intervals may be extended during inactive periods commensurate with adequate preservation.

- c. For lubrication instructions during continued operation below 0°F (-18°C), refer to FM 9-207.

- d. Refer to TM 9-238 for lubrication instructions before and after fording.

e. After operation in muddy, sandy, or dusty conditions, clean and inspect all points of lubrication for fouled lubricants. Change lubricants as required.

LUBRICATION CHART

TRAILER, CARGO: 1/4-TON, 2-WHEEL

M416 (NSN 2330-00-706-5495)

M416A1 (NSN 2330-01-046-2855)

Intervals (on-condition or hard time) and related man-hour times are based on normal operation. The man-hour time specified is the time you need to do all services prescribed for a particular interval. Decrease the intervals if your lubricants are contaminated, or if you are operating equipment under adverse conditions, including longer-than-usual operating hours. The intervals may be extended during periods of low activity. If extended, adequate preservation precautions must be taken.

Dotted leader lines indicate lubrication is required on both sides of the equipment.

—————
WARNING
—————

Dry cleaning solvent P-D-680 is toxic and flammable. Always wear protective goggles and gloves, and use only in a well-ventilated

area. Avoid contact with skin, eyes, and clothes, and DO NOT breathe vapors. DO NOT use near open flame or excessive heat. The solvent's flash point is 100°F-130°F (38°C-59°C). If you become dizzy while using cleaning solvent, immediately get fresh air and medical help. If solvent contacts eyes, immediately wash your eyes and get medical aid.

Clean all fittings and area around lubrication points with dry cleaning solvent (Item 10, Appendix E) or equivalent before lubricating equipment. After lubrication, wipe off excess oil or grease to prevent accumulation of foreign matter.

The lowest level of maintenance authorized to lubricate a point is indicated in parentheses by use of the following: (C) Operator/Crew; or (O) Organizational Maintenance.

LUBRICANT • INTERVAL

INTERVAL • LUBRICANT

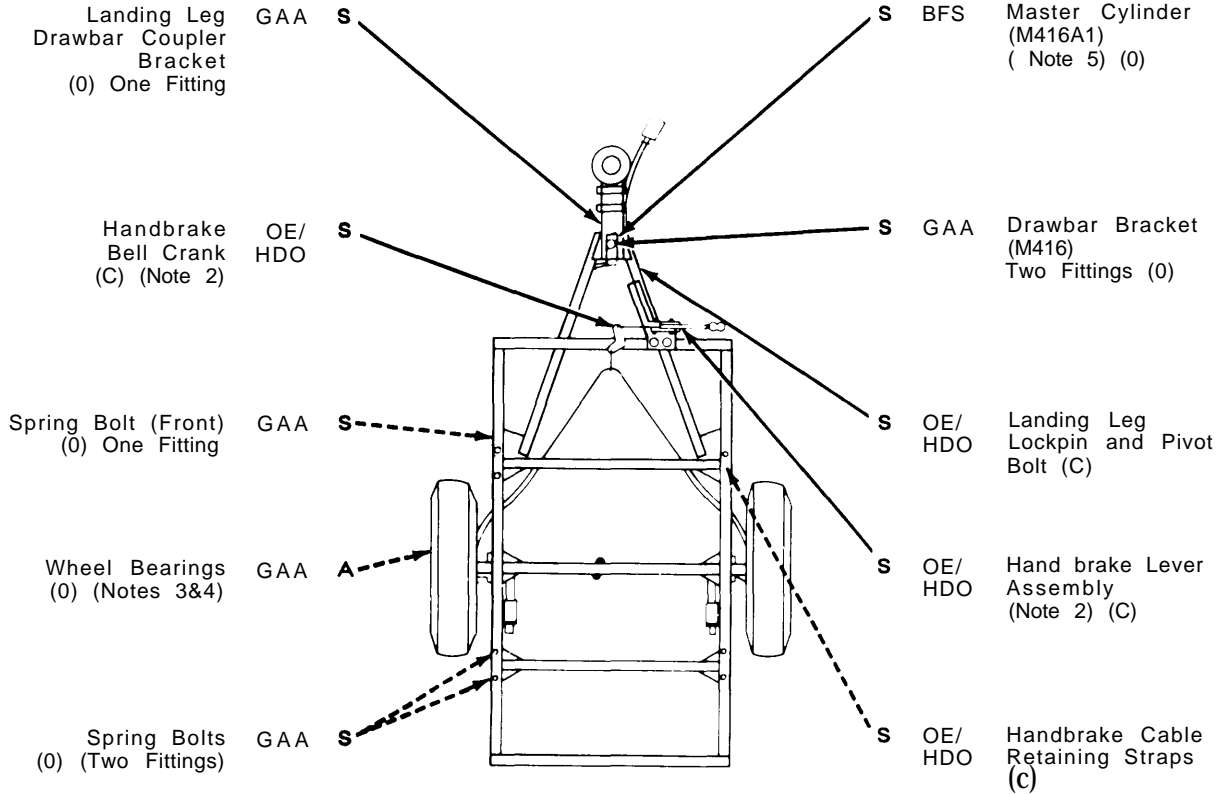

TOTAL MAN-HOURS*

INTERVAL	MAN-HOUR
S	2.2
A	0.8

* The man-hours time specified is the time you need to do all services prescribed for a particular interval.

TA503894

- KEY -

LUBRICANTS	EXPECTED TEMPERATURES			INTERVALS
	ABOVE +15°F (ABOVE -9°C)	+40°F to -15°F (+4°C to -26°C)	+40° F to -65° F (+4°c 'o -54°C)	
OE/HDO (MIL-L-2104) Lubricating Oil, Internal Combustion Engine, Tactical Service	OE/HDo-30	OE/HDO-10	OEA (Note 1)	S -Semiannual A -Annual
OEA (MIL-L-46167) Lubricating Oil, Interns Combustion, Arctic			OEA (Note 1)	
BFS (MIL-L-46176) Brake Fluid Silicone, Automotive	All Temperatures			
GAA (MIL-G-10924) Grease, Automotive and Artillery	All Temperatures			

FOR ARCTIC OPERATIONS, REFER TO FM 9-207

NOTES:

1. FOR OPERATION OF EQUIPMENT IN PROTRACTED COLD TEMPERATURES BELOW 15°F (-26°C). Remove lubricants prescribed in the key for temperatures above 15°F (-26°C). Lubricate with lubricants specified in the key for temperatures below 15°F (-26°C), If OEA lubricant is required to meet the temperature changes prescribed in the key, OEA lubricant is to be used in place of OE/HDO-10 lubricant for all temperature ranges where OE/HDO-10 lubricant is specified in the key.

2. OIL CAN POINTS. Every six months lubricate linkage pins, clevises, and all exposed adjusting threads with OE/HDO.

3. WHEEL BEARINGS. Every 12 months, remove, clean, and pack with GAA. Refer to TM 9-214, Inspection, Care, and Maintenance of *Antifriction Bearings*.

4. HUBCAP. Apply a light coating of sealing compound (Item 3, Appendix E) or equivalent to outer surface of cap's flange prior to pressing cap in the hub.

5. MASTER CYLINDER. Fill master cylinder to within ½ in. (13 mm) from top.

Section II. OPERATOR/CREW TROUBLESHOOTING PROCEDURES

Paragraph Title	Page Number
General	3-6
Operator/Crew Troubleshooting, Table 3-1	3-7
Troubleshooting Symptom Index	3-7

3-4. GENERAL.

a. This section provides information for identifying and correcting malfunctions which may develop while operating your trailer.

b. The Troubleshooting Symptom Index in paragraph 3-5 lists common malfunctions which may occur, and refers you to the proper page in Table 3-1 for a troubleshooting procedure.

c. If you are unsure of the location of an item mentioned in troubleshooting, refer to paragraph 1-7 or the maintenance task where the item is replaced.

d. Before performing troubleshooting, read and follow all safety instructions found in the Warning Summary at the front of this manual.

e. This section cannot list all malfunctions that may occur, nor all tests or inspections and corrective actions. If a malfunction is not listed, or is not corrected by listed corrective actions, notify your supervisor.

f. When troubleshooting a malfunction:

(1) Locate the symptom or symptoms in paragraph 3-5 that best describe the malfunction.

(2) Turn to the page in Table 3-1 where the troubleshooting procedures for the malfunction in question are described. Headings at the top of each page show how each troubleshooting procedure is organized: MALFUNCTION, TEST OR INSPECTION (in step number order), and CORRECTIVE ACTION.

(3) Perform each step in the order listed until the malfunction is corrected. DO NOT perform any maintenance task unless the troubleshooting procedure tells you to do so.

g. The columns in Table 3-1 are defined as follows:

(1) **MALFUNCTION.** A visual or operational indication that something is wrong with the trailer.

(2) **TEST OR INSPECTION.** A procedure to isolate the problem in a component or system.

(3) **CORRECTIVE ACTION.** A procedure to correct the problem.

3-5. TROUBLESHOOTING SYMPTOM INDEX.

	Troubleshooting Procedure Page
BRAKES	
Brakes Will Not Release	3-8
No Brakes (M416Al)	3-8
ELECTRICAL SYSTEM	
All Lamps Fail to Light	3-7
One or More Lamps (But Not All) Fail to Light	3-7

Table 3-1. Operator/Crew Troubleshooting.

MALFUNCTION

TEST OR Inspection
Corrective ACTION

ELECTRICAL SYSTEM

1. ALL LAMPS FAIL TO LIGHT.

- Step 1. Check that towing vehicle lights are turned on.
Turn on lights in towing vehicle.
- Step 2. Check intervehicular cable for proper connection.
Connect intervehicular cable (para 2-6).
- Step 3. Check towing vehicle circuit breaker/fuse.
Refer to towing vehicle technical manual for instructions.
If lamps still do not light, notify organizational maintenance.

2. ONE OR MORE LAMPS (BUT NOT ALL) FAIL TO LIGHT.

- Check for loose plug connectors at affected light.
Connect loose plug connectors.
If lamps still do not light, notify organizational maintenance.

Table 3-1, Operator/Crew Troubleshooting (Con't).

MALFUNCTION
TEST OR INSPECTION
CORRECTIVE ACTION

BRAKES

3. BRAKES WILL NOT RELEASE.

NOTE

Step 1 applies to M416A1 only.

Step 1. Check that breakaway lever is not engaged in leaf spring (para 2-2).

Disengage breakaway lever.

Step 2. Check for proper handbrake lever adjustment.

Adjust handbrake lever (para 3-6).

If brakes still will not release, notify organizational maintenance.

4. NO BRAKES (M416A1).

Check for obstruction in brake actuator (para 1-7),

Clear obstruction.

If trailer still has no brakes, notify organizational maintenance.

Section III. MAINTENANCE PROCEDURES

Paragraph Title	Page Number
Handbrake Lever Adjustment.	3-9
Wheel Replacement	3-10

3-6. HANDBRAKE LEVER ADJUSTMENT.

NOTE

Handbrake lever(1) is properly adjusted when additional force is needed to move handbrake lever beyond halfway point of travel toward the applied position.

- a. Release handbrake lever (1).
- b. Rotate adjustment knob (2) clockwise to tighten, counterclockwise to loosen.
- c. Check adjustment. Repeat steps a and b as required.

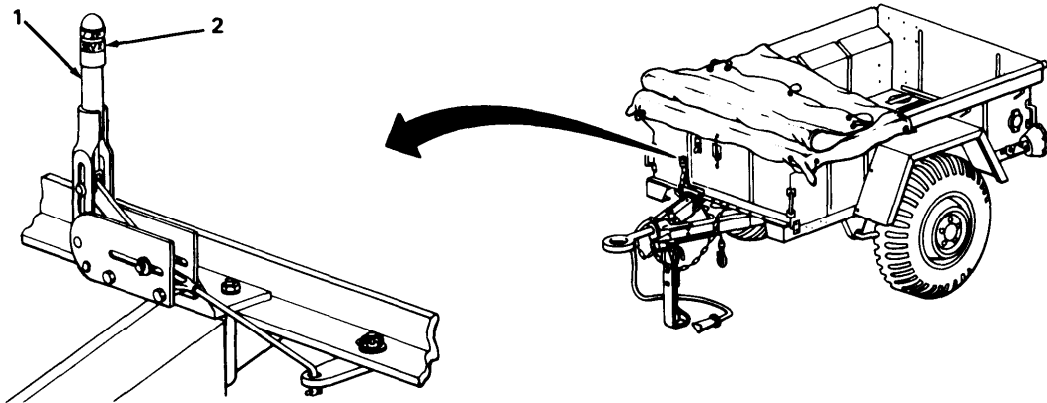

3-7. WHEEL REPLACEMENT.

a. Removal.

- (1) Apply handbrake lever.
- (2) Loosen, but do not remove, 5 nuts (3).
- (3) Position floor jack under axle (1) near wheel (2) to be removed. Raise axle until wheel is off ground.
- (4) Remove 5 nuts (3).
- (5) Remove wheel (2) from wheel hub (4).

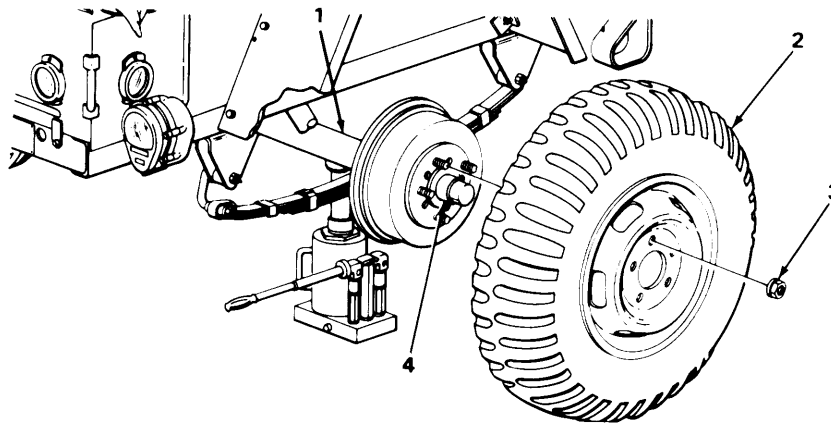

b. Installation,

- (1) Position wheel (2) on wheel hub (4).
- (2) Install and tighten 5 nuts (3) finger tight.
- (3) Lower axle (1) until wheel (2) is on ground. Remove floor jack.
- (4) Tighten 5 nuts (3) using tightening sequence shown. Have organizational maintenance tighten nuts to 85 lb. -ft. (115 N•m) in same sequence.

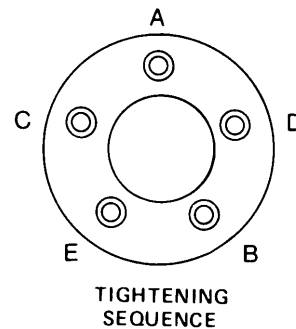

CHAPTER 4 ORGANIZATIONAL MAINTENANCE

Section 1. REPAIR PARTS; SPECIAL TOOLS; TEST, MEASUREMENT, AND DIAGNOSTIC EQUIPMENT (TMDE); AND SUPPORT EQUIPMENT

Paragraph Title	Page Number
Common Tools and Equipment	4-1
Repair Parts	4-1
Special Tools; Test, Measurement, and Diagnostic Equipment (TMDE); and Support Equipment.	4-1

4-1. COMMON TOOLS AND EQUIPMENT.

For authorized common tools and equipment, refer to the Modified Tab/e of Organization and Equipment (MTOE) applicable to your unit.

4-2. SPECIAL TOOLS; TEST, MEASUREMENT, AND DIAGNOSTIC EQUIPMENT (TMDE); AND SUPPORT EQUIPMENT.

No special tools, TMDE, or support equipment are required to maintain the trailers.

4-3. REPAIR PARTS.

Repair parts are listed and illustrated in Appendix F of this manual.

Section II. SERVICE UPON RECEIPT

Paragraph Title	Page Number
General.....	4-1
Preliminary inspection.....	4-2
Preliminary Servicing and Adjustment	4-2

4-4. GENERAL.

When an M416 or M416A1 Cargo Trailer is first received by the using unit, determine whether it has been properly prepared for service and is in condition to perform its mission. Follow the instruction in paragraph 4-5 and 4-6.

4-5. PRELIMINARY INSPECTION.

- a. Read and follow all instructions on DD Form 1397.
- b. Remove all strapping, plywood tape, seals, and wrapping.

WARNING

Dry cleaning solvent P-D-680 is toxic and flammable. Always wear protective goggles and gloves, and use only in a well-ventilated area. Avoid contact with skin, eyes, and clothes, and DO NOT breathe vapors. DO NOT use near open flame or excessive heat. The solvent's flash point is 100°F-130°F (38°C-59°C), If you become dizzy while using cleaning solvent, immediately get fresh air and medical help. If solvent contacts eyes, immediately wash your eyes and get medical aid.

- c. Remove rust preventive compound using dry cleaning solvent (Item 10, Appendix E) and rags (Item 9, Appendix E).
- d. Inspect the trailer for damage incurred during shipment. Check also to see if the equipment has been modified.
- e. Check the equipment against the packing list to see if the shipment is complete.
- f. Report all discrepancies in accordance with instructions in DA Pam 738-750.

4-6. PRELIMINARY SERVICING AND ADJUSTMENT.

- a. Perform all operator/crew and organizational PMCS. Schedule the next PMCS on DD Form 314.
- b. If any system of the trailer does not operate properly, refer to the troubleshooting instructions in Chapter 3, Section II, or to Section IV of this chapter.
- c. Perform all lubrication regardless of interval (Chapter 3, Section 1),
- d. Report all problems on DA Form 2404 if the deficiencies appear to involve unsatisfactory design.
- e. Perform a break-in road test of 25 mi (40 km) at a maximum speed of 55 mi/h (88 km/h).

**Section III. ORGANIZATIONAL PREVENTIVE MAINTENANCE
CHECKS AND SERVICES (PMCS)**

Paragraph Title	Page Number
General	4-2
Organizational Preventive Maintenance Checks and Services (PMCS), Table 4-1	4-4
PMCS Procedures	4-3

4-7. GENERAL.

- a. Preventive maintenance is detecting/correcting problems before they happen or fixing minor problems before they become major problems.

4-7. GENERAL (Con't).

b. Table 4-1 contains a list of preventive maintenance checks and services to be performed by organizational maintenance personnel. Attention to these checks and services will increase the useful life of the equipment.

c. Every possible problem cannot be covered in the PMCS. Be alert for anything that might cause a problem. If anything looks wrong, and you can't fix it, write it on a DA Form 2404 and report it to your supervisor. Be sure to record any corrective action taken.

4-8. PMCS PROCEDURES,

a. While performing your PMCS, always keep in mind all WARNINGS and CAUTIONS.

b. Perform the preventive maintenance checks and services at the intervals shown in Table 4-1.

(1) Perform *Semiannual* (S) PMCS twice a year, or once each six months.

(2) Perform *Annual* (A) PMCS once each year.

c. Always do your checks and services in the same order so it gets to be a habit. Once you've had some practice, you'll spot anything wrong in a hurry.

d. If the trailer doesn't work properly and you can't see what is wrong, refer to Section IV of this chapter for troubleshooting instructions.

WARNING

Dry cleaning solvent P-D-680 is toxic and flammable. Always wear protective goggles and gloves, and use only in a well-ventilated area. Avoid contact with skin, eye, and clothes, and DO NOT breathe vapors. DO NOT use near open flame or excessive heat. The solvent's flash point is 100°F-130°F (38°C-59°C). If you become dizzy while using cleaning solvent, immediately get fresh air and medical help. If solvent contacts eyes, immediately wash your eyes and get medical aid.

e. Make cleanup a part of your preventive maintenance. Dirt, grease, oil, and debris may cover up a serious problem. Wipe off excess grease and spilled oil. Use dry cleaning solvent (Item 10, Appendix E) to clean metal surfaces. Use soap (Item 4, Appendix E) and water to clean rubber or plastic material.

f. Watch for and correct anything that might cause a problem with the equipment. Some things you should watch for are:

(1) Bolts, nuts, and screws that are loose, missing, bent, or broken.

(2) Welds that are bad or broken.

(3) Electric wires and connectors that are bare, broken, or loose.

(4) Hydraulic hoses and tube assemblies that leak or show signs of damage or wear (M416A1 only).

g. For a classification of fluid leakage, refer to paragraph 2-5.

h. The columns in Table 4-1 are defined as follows:

(1) **Item No.** The number in this column shall be used as a source of item numbers for the "TM ITEM NO" column on DA Form 2404 in recording results of PMCS.

(2) **Interval.** Tells you when to do a certain check or service.

4-8. PMCS PROCEDURES (Con't).

- (3) **Item To Be Inspected.** Lists system and common names of items that are to be inspected.
- (4) **Procedures.** Tells you how to do the required check or service.

Table 4-1. Organizational Preventive Maintenance Checks and Services (PMCS).

S - Semiannual

A - Annual

ITEM NO.	INTERVAL		ITEM TO BE INSPECTED	PROCEDURES
	S	A		
1	●		BODY AND FENDERS	<p style="text-align: center;">NOTE</p> <p>Perform operator/crew PMCS prior to or in conjunction with organizational PMCS.</p> <p>Look for cracks and dents. Check that fenders are secured to body.</p>
3	●	FRAME	<p>Look for cracks, bent members, or broken welds. Notify direct support maintenance of any damage found.</p>	
				4
5	●	WHEEL BEARINGS	<p>Remove hubs and wheel bearings. Clean, inspect, and pack wheel bearings (para 4-36 or 4-37).</p>	
				6
7	●	MASTER CYLINDER (M416A1)	<p>Check fluid level in master cylinder. Fill to ½ in. (13 mm) from top (Chapter 3, Section 1).</p>	

Section IV. ORGANIZATIONAL TROUBLESHOOTING PROCEDURES

Paragraph Title	Page Number
General	4-5
Organizational Troubleshooting, Table 4-2	4-6
Troubleshooting Symptom Index	4-5

4-9. GENERAL.

a. This section contains troubleshooting information and tests for locating and correcting some of the malfunctions that may develop in the trailers.

b. The Troubleshooting Symptom Index in paragraph 4-10 lists common malfunctions which may occur and refers you to the proper page in Table 4-2 for a troubleshooting procedure.

c. This manual cannot list all the malfunctions that might occur, nor all tests or inspections and corrective actions. If a malfunction is not listed, or is not corrected by the listed corrective actions, notify direct support maintenance.

d. When troubleshooting a malfunction:

(1) Question the operator to obtain any information that might help determine the cause of the problem. Before continuing, ensure that all applicable operator/crew troubleshooting was performed.

(2) Locate the symptom or symptoms in paragraph 4-10 that best describe the malfunction. If the appropriate symptom is not listed, notify direct support maintenance.

(3) Turn to the page in Table 4-2 where the troubleshooting procedures for the malfunction in question are described. Headings at the top of each page show how each troubleshooting procedure is organized: MALFUNCTION, TEST OR INSPECTION (in step number order), and CORRECTIVE ACTION.

(4) Perform each step in the order listed until the malfunction is corrected. DO NOT perform any maintenance task unless the troubleshooting procedure tells you to do so.

4-10. TROUBLESHOOTING SYMPTOM INDEX.

	Troubleshooting Procedure Page
BRAKES	
Brakes Will Not Release	4-7
Handbrake Will Not Hold	4-7
No Brakes (M416A1)	4-8
Weak Brakes (M416A1)	4-8
ELECTRICAL SYSTEM	
Lamps Dim or Flickering	4-6
One or More Lamps (But Not All) Fail to night	4-6

Table 4-2. Organizational Troubleshooting,

MALFUNCTION	TEST OR INSPECTION	CORRECTIVE ACTION
-------------	--------------------	-------------------

ELECTRICAL SYSTEM

1. LAMPS DIM OR FLICKERING.

WARNING

When troubleshooting an electrical malfunction, ALWAYS disconnect intervehicular cable from towing vehicle. Failure to do so may result in injury or death due to electric shock.

NOTE

Refer to paragraph 4-23 to determine routing of electrical wires and location of electrical components.

- Step 1. Check continuity between intervehicular cable pin D and ground wire terminal end,
If no continuity exists, replace intervehicular cable (para 4-20),
- Step 2. Check continuity between ground wire terminal end and trailer frame.
If no continuity exists, remove terminal end from frame and clean mating surfaces.
- Step 3. Check continuity between edge of lamp socket and light assembly mounting hardware.
If no continuity exists, replace light assembly (para 4-15, 4-17, or 4-19).
- Step 4. Check continuity between edge of lamp socket and trailer frame,
If no continuity exists, remove and clean mating surfaces.

2. ONE OR MORE LAMPS (BUT NOT ALL) FAIL TO LIGHT.

WARNING

When troubleshooting an electrical malfunction, ALWAYS disconnect intervehicular cable from towing vehicle. Failure to do so may result in injury or death due to electric shock.

NOTE

Refer to paragraph 4-23 to determine routing of electrical wires and location of electrical components,

- Step 1. Check lamps.
Remove and replace unserviceable lamps (para 4-14, 4-17, or 4-19).
- Step 2. Check continuity between center post of lamp socket and related light assembly plug connector.
If no continuity exists, replace light assembly (para 4-15, 4-17, or 4-19).

Table 4-2. Organizational Troubleshooting (Con't).

MALFUNCTION	TEST OR INSPECTION	CORRECTIVE ACTION
Step 3.	Check continuity between edge of lamp socket and trailer frame. If no continuity exists, remove and clean mating surfaces.	
Step 4.	Disconnect chassis wiring harness from intervehicular cable. Have assistant operate towing vehicle lights. Check voltage in affected lines of intervehicular cable. If 24 volts are present in affected lines, replace chassis wiring harness (para 4-21).	
Step 5.	Disconnect intervehicular cable from towing vehicle receptacle. Have assistant operate towing vehicle lights. Check voltage at towing vehicle receptacle. If voltage is present at all sockets of towing vehicle receptacle, replace intervehicular cable (para 4-20). If voltage is not present at all sockets of towing vehicle receptacle, refer to applicable towing vehicle maintenance manual.	

BRAKES

3. BRAKES WILL NOT RELEASE.

- Step 1. Check for binding or damaged handbrake cable.
Replace handbrake cable (para 4-27).
- Step 2. Check for improperly adjusted brakes.
Adjust brakes (para 4-28 or 4-29).
- Step 3. Check for separation of brakeshoe and lining.
Replace brakeshoes (para 4-30 or 4-31).

4. HANDBRAKE WILL NOT HOLD.

- Step 1. Check for binding handbrake cable or linkage.
Replace handbrake cable or linkage (para 4-27).
- Step 2. Check for improperly adjusted handbrake lever.
Adjust handbrake lever (para 3-6).
- Step 3. Check for improperly adjusted brakes.
Adjust brakes (para 4-28 or 4-29).
- Step 4. Check for worn brakeshoe linings.
If brakeshoe lining thickness is 1/8 in. (3.2 mm) or less, replace brakeshoes (para 4-30 or 4-31).

Table 4-2. Organizational Troubleshooting (Con't).

MALFUNCTION	TEST OR INSPECTION	CORRECTIVE ACTION
-------------	--------------------	-------------------

5. NO BRAKES OR WEAK BRAKES (M416A1).

- Step 1. Check for frozen brake actuator as follows:
- a. Ensure that handbrake lever is applied.
 - b. Check master cylinder for adequate fluid level. Fluid level must be within ½ in. (13mm) from top.
 - c. Apply pressure to drawbar coupler, causing actuator to move.
 - d. Actuator can be checked further by manually pulling on the breakaway chain, thereby setting brake. Breakaway lever can be reset using a screwdriver.
- If actuator does not move, remove and repair (para 4-40).
- Step 2. Check master cylinder for adequate fluid level. Fluid level must be within ½ in, (13 mm) from top.
- Add fluid if level is low (Chapter 3, Section 1).
- Bleed brakes (para 4-33).
- Step 3. Check for improperly adjusted brakes.
- Adjust brakes (para 4-28 or 4-29).
- Step 4. Check for worn brakeshoe linings.
- If brakeshoe lining thickness is 1/8 in. (3.2 mm) or less, replace brakeshoes (para 4-30 or 4-31).
- Step 5. Inspect wheel cylinders for leaks.
- Replace wheel cylinders (para 4-32).

Section V. GENERAL MAINTENANCE INSTRUCTIONS

Paragraph Title	Page Number
Cleaning instruction	4-9
General	4-9
Inspection Instructions	4-10

4-11. GENERAL.

a. This section provides general shop practices and specific methods you must be familiar with to properly maintain the trailers. You should read and understand these practices and methods before performing organizational maintenance tasks.

b. The following "Initial/Setup" information applies to all maintenance procedures in this manual:

(1) Only those resources required to perform the procedure are listed.

(2) Personnel are listed only if the task requires more than one technician. If "Personnel/Required" is not listed, one technician can do the task.

4-12. CLEANING INSTRUCTIONS.

WARNING

Improper cleaning methods and use of unauthorized cleaning liquids or solvents can injure personnel and damage equipment. To prevent this, refer to TM 9-247 for further instructions.

i. **Importance.** The importance of cleaning must be thoroughly understood by maintenance personnel. Care and effort are required in cleaning. Dirt and foreign material are a constant threat to satisfactory maintenance.

b. **Parts/Components.** Cleaning instructions are the same for the majority of parts and components that make up the trailer.

c. **General Cleaning Instructions.** The following apply to all cleaning operations:

(1) Clean all parts before inspection, after repair, and before assembly.

(2) Keep hands as free of grease as possible. Grease can collect dust, dirt, or grit.

(3) After cleaning, cover all parts to protect them from dust and dirt. Lightly oil parts that are subject to rust.

d. **Steam Cleaning.**

(1) Before steam cleaning exterior of trailer, protect all electrical equipment that can be damaged by steam or moisture.

(2) Place disassembled parts in a suitable container to steam clean.

(3) After cleaning, dry and cover all parts. Lightly oil parts that are subject to rust.

4-12, CLEANING INSTRUCTIONS (Con't).

e. Castings, Forgings, and Machined Metal Parts.

WARNING

Dry cleaning solvent P-D-680 is toxic and flammable. Always wear protective goggles and gloves, and use only in a well-ventilated area. Avoid contact with skin, eyes, and clothes, and DO NOT breathe vapors. DO NOT use near open flame or excessive heat. The solvent's flash point is 100°F-130°F (38°C-59°C). If you become dizzy while using cleaning solvent, immediately get fresh air and medical help. If solvent contacts eyes, immediately wash your eyes and get medical aid.

- (1) Clean inner and outer surfaces with dry cleaning solvent (Item 10, Appendix E).
- (2) Remove grease and accumulated deposits with a stiff bristle brush.

WARNING

Compressed air used for cleaning and drying purposes, or for clearing restrictions, should never exceed 30 psi (207 kPa). Wear protective clothing (goggles/shield, gloves, etc.) and use caution to avoid injury to personnel.

- (3) Use compressed air to remove dirt and cleaning fluids from all threaded holes.

f. Electrical Cables and Flexible Hoses.

CAUTION

Do not wash electrical cables and flexible hoses with dry cleaning solvent or mineral spirits. Failure to follow this caution will seriously damage or destroy the material.

Wash electrical cables and flexible hoses with soap (Item 4, Appendix E) and water solution and wipe dry.

g. Bearings. Refer to TM 9-214 for instructions on the inspection, care, and maintenance of antifriction bearings.

4-13. INSPECTION INSTRUCTIONS.

All components and parts must be checked carefully to determine if they are serviceable for reuse. Specific inspection instructions are as follows:

a. Drilled and Threaded Holes and Surfaces.

- (1) Inspect for wear, distortion, cracks, or any other damage in or around holes and threaded surfaces.
- (2) Inspect threaded areas for evidence of cross threading.
- (3) Mark all damaged areas for repair or replacement.

b. Metal Lines, Flexible Lines (Hoses), and Metal Fittings.

- (1) Inspect flexible lines for fraying, evidence of leakage, or loose metal fittings or connectors.
- (2) Inspect metal lines for sharp kinks, cracks, and bad bends or dents.

c. Bushings. Inspect bushings for excessive wear, elongation, or grooving.

d. Machined Surfaces. Inspect machined surfaces for scoring or other obvious damage.

Section VI. ELECTRICAL SYSTEM MAINTENANCE

Paragraph Title	Page Number
Blackout Stoplight Lamp Replacement (M416)	4-15
Blackout Stoplight Replacement (M416)	4-16
Chassis Wiring Harness Replacement	4-22
Composite Light Lamp Replacement (M416A1)	4-11
Composite Light Replacement (M416A1)	4-13
Intervehicular Cable Replacement	4-20
Stoplight Taillight Lamp Replacement (M416)	4-17
Stoplight Taillight Replacement (M416)	4-18
Wiring Diagrams.....	4-26
Wiring Harness Repair	4-24

4-14. COMPOSITE LIGHT LAMP REPLACEMENT (M416A1).

This Task Covers:

- a. Removal
- b. Installation

Initial Setup:

Equipment Conditions:

- Intervehicular cable disconnected from towing vehicle (para 2-8).

Tools/Test Equipment:

- General mechanic's tool kit

a. REMOVAL

1. Loosen 6 captive screws (2).

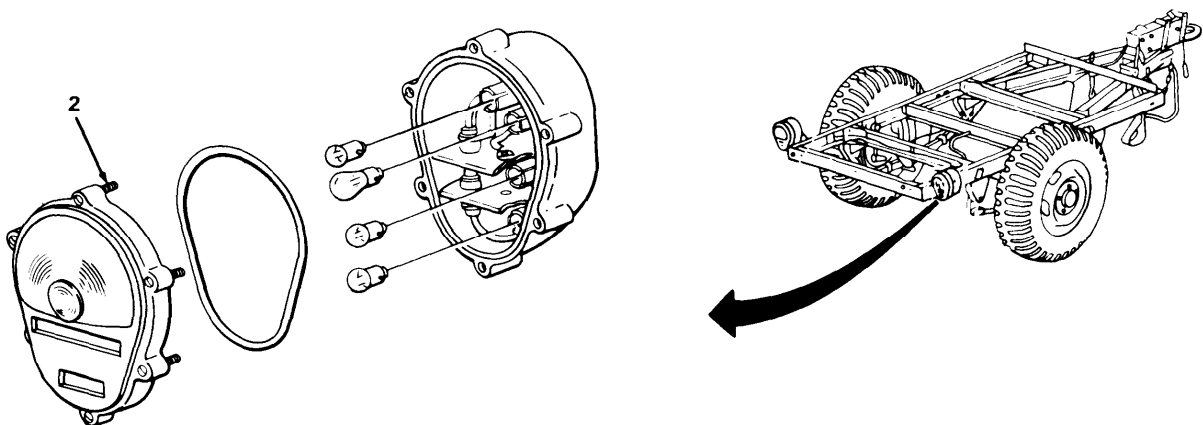

4-14. COMPOSITE LIGHT LAMP REPLACEMENT (M416A1) (Con't).

2. Remove door and lens assembly (1) from body (7). Inspect preformed packing (3) for damage. If damaged, remove and discard.
3. Remove 2 lamps (10) from sockets (9). Remove lamp (5) from socket (6). Remove lamp (4) from socket (8).

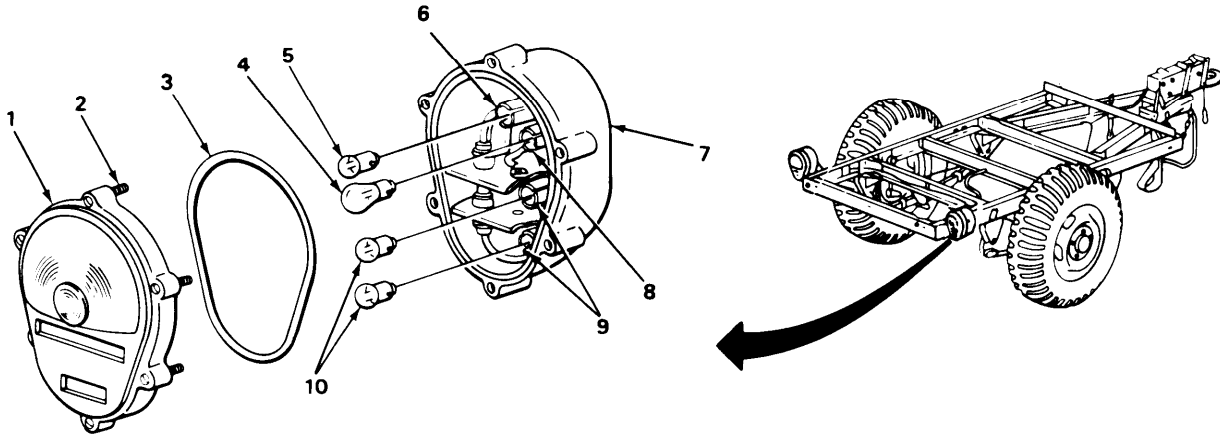

b. INSTALLATION

1. Install 2 lamps (10) in sockets (9). Install lamp (4) in socket (8). Install lamp (5) in socket (6).
2. If removed, install new preformed packing (3) in door and lens assembly (1). Position door and lens assembly on body (7), and tighten 6 captive screws (2).

FOLLOW-ON TASKS:

- Connect intervehicular cable to towing vehicle (para 2-6),
- Check operation of light.

4-15. COMPOSITE LIGHT REPLACEMENT (M416A1).

This Task Covers:

a. Removal

b. Installation

Initial Setup:

Equipment Conditions:

- Intervehicular cable disconnected from towing vehicle (para 2-8).

Tools/Test Equipment:

- General mechanic's tool kit

Materials/Parts:

- Marker tags (as required) (Item 11, Appendix E)
- One grommet
- Four lockwashers

a. REMOVAL

1. Tag wires for installation if identification bands are missing or not legible.
2. Remove 4 connectors (5 and 6) from 2 clip assemblies (2). Disconnect 4 connectors.
3. Remove grommet (4) from framerail (1) and discard.
4. Pull 4 connectors (5) through hole (3) in framerail (1).

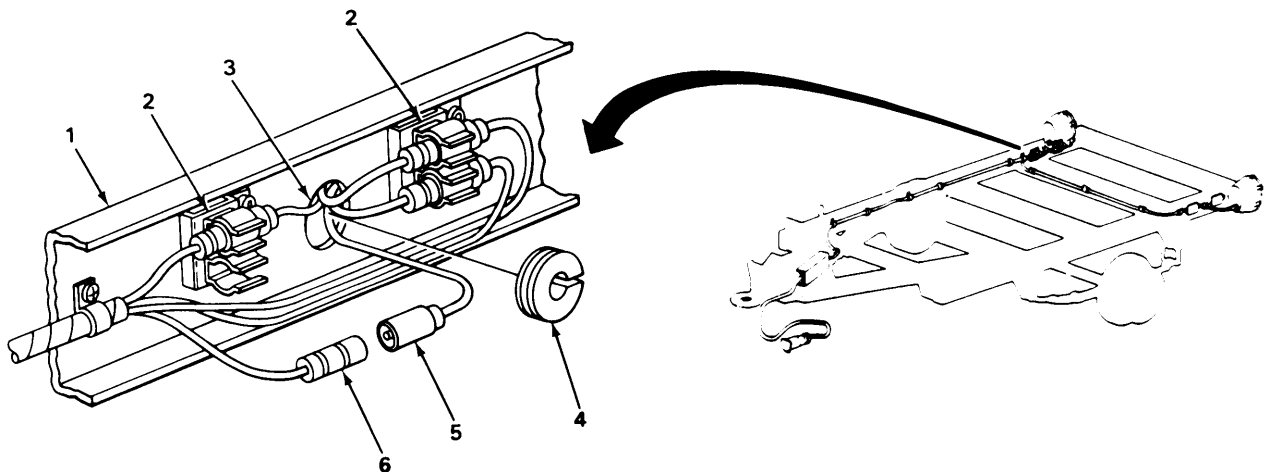

TA503899

4-15. COMPOSITE LIGHT REPLACEMENT (M416A1) (Con't).

5. Remove 2 screws (10), lockwashers (11), and composite light (7) from bracket (13). Discard lockwashers.
6. Remove 2 nuts (8), lockwashers (9), and bolts (12) securing bracket (13) to framerail (1). Remove bracket from framerail. Discard lockwashers.

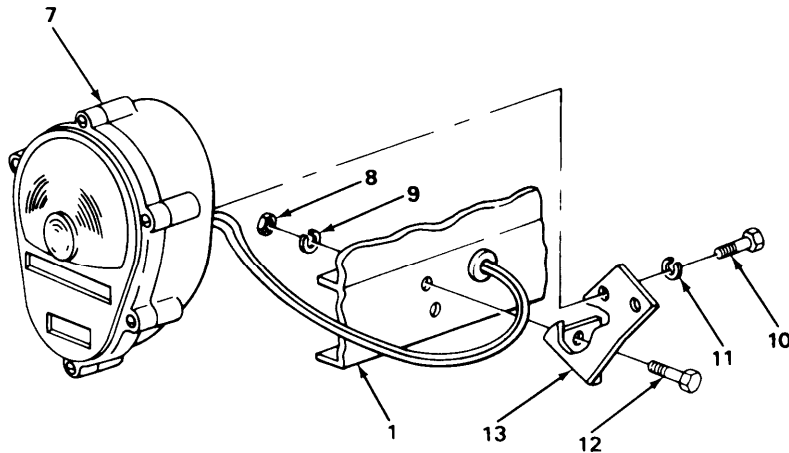

b. INSTALLATION

1. Install bracket (13) on framerail (1) with 2 bolts (12), new lockwashers (9), and nuts (8).
2. Install composite light (7) on bracket (13) with 2 new lockwashers (11) and screws (10).
3. Insert 4 connectors (5) through hole (3) in framerail (1).
4. Install new grommet (4) in hole (3).
5. Connect 4 connectors (5 and 6) and install in 2 clip assemblies (2).

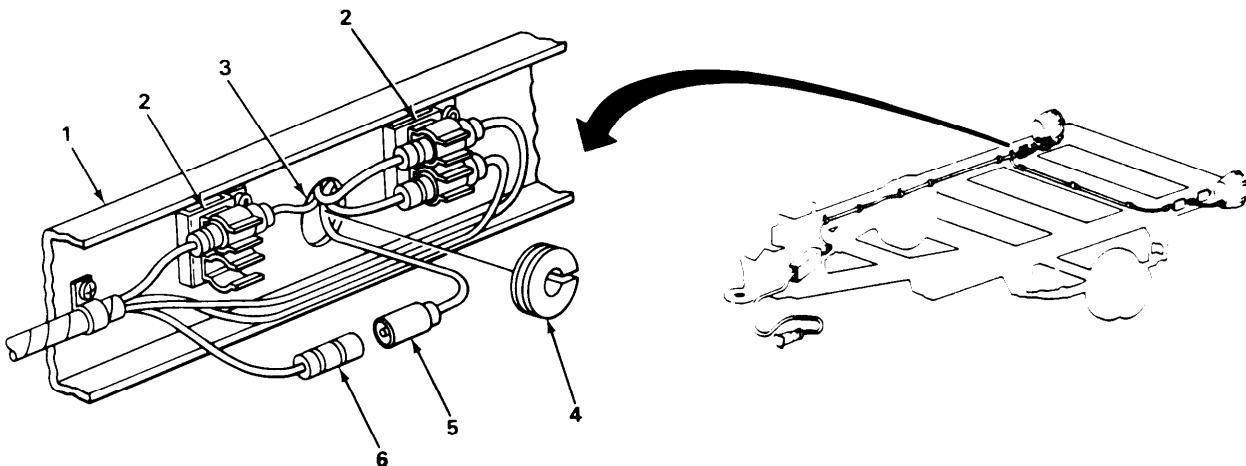

FOLLOW-ON TASKS:

- Connect intervehicular cable to towing vehicle (para 2-6).
- Check operation of light.

TA503900

4-16. BLACKOUT STOPLIGHT LAMP REPLACEMENT (M416).

This Task Covers:

a. Removal

b. Installation

Initial Setup:

Equipment Conditions:

- Intervehicular cable disconnected from towing vehicle (para 2-8).

Tools/Test Equipment:

- General mechanic's tool kit
-

a. REMOVAL

1. Remove 2 screws (1) and lens retainer (2) from housing (4). Inspect gasket (3) for damage. If damaged, remove **and discard**.
2. Remove lamp (6) from socket (5). Discard lamp if unserviceable.

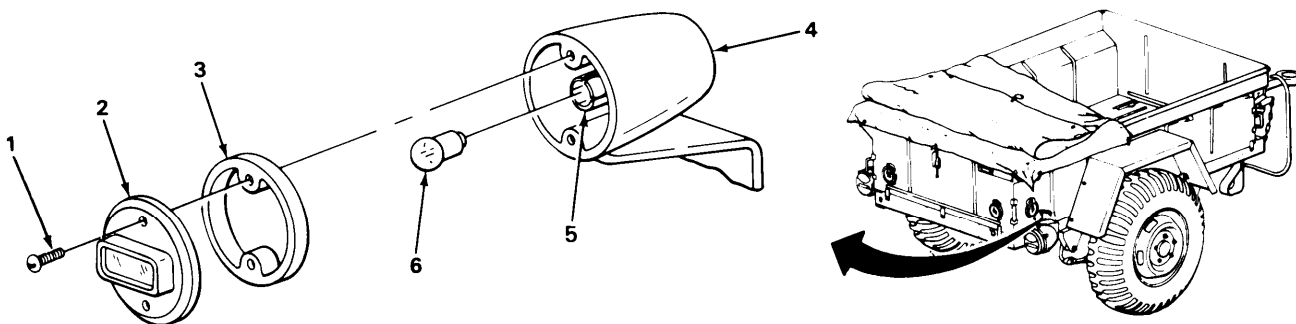

b. INSTALLATION

1. Install lamp (6) in socket (5).
2. If removed, install new gasket (3) in lens retainer (2).
3. Install lens retainer (2) on housing (4) with 2 screws (1).

FOLLOW-ON TASKS:

- Connect intervehicular cable to towing vehicle (para 2-6).
- Check operation of light.

4-17. BLACKOUT STOPLIGHT REPLACEMENT (M416).

This Task Covers:

- a. Removal b. Installation
-

Initial Setup:

Equipment Conditions:

- Intervehicular cable disconnected from towing vehicle (para 2-8).

Materials/Parts:

- One Lockwasher

Tools/Test Equipment:

- General mechanic's tool kit
-

a. REMOVAL

1. Disconnect connector (2) from blackout stoplight (1).
2. Remove screw (5), lockwasher (4), and blackout stoplight (1) from bracket (3). Discard lockwasher.

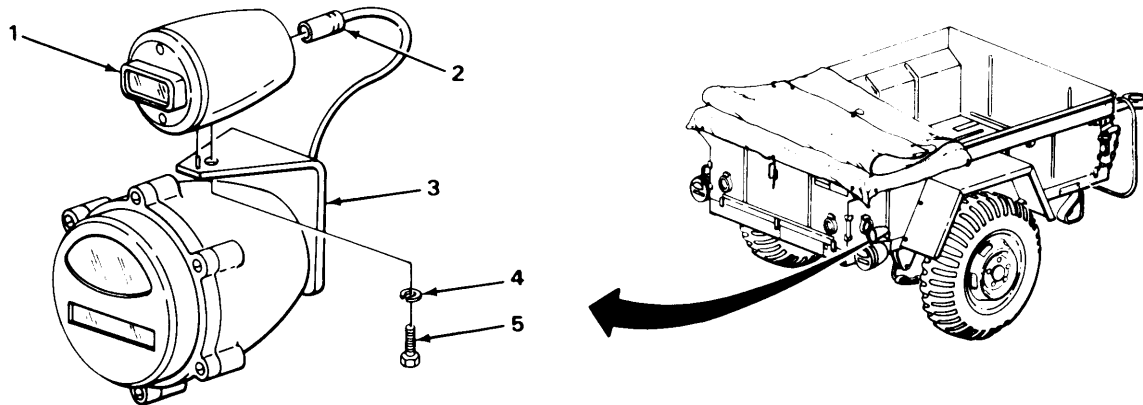

b. INSTALLATION

1. Aline hole in blackout stoplight (1) with pin on bracket (3). Install new lockwasher (4) and screw (5) to secure blackout stoplight to bracket.
2. Connect connector (2) to blackout stoplight (1).

FOLLOW-ON TASKS:

- Connect intervehicular cable to towing vehicle (para 2-6).
- Check operation of light.

4-18. STOPLIGHT TAILLIGHT LAMP REPLACEMENT (M416).

This Task Covers:

- a. Removal b. Installation
-

Initial Setup:

Equipment Conditions:

- InterVehicular cable disconnected from towing vehicle (para 2-8).

Tools/Test Equipment:

- General mechanic's tool kit
-

a. REMOVAL

1. Loosen 6 captive screws (2) and remove door assembly (1) from housing (5).
2. Inspect preformed packing (8) for damage. If damaged, remove and discard.
3. Remove 2 lamps (6) from sockets (3). Remove lamp (7) from socket (4). Discard lamps if unserviceable.

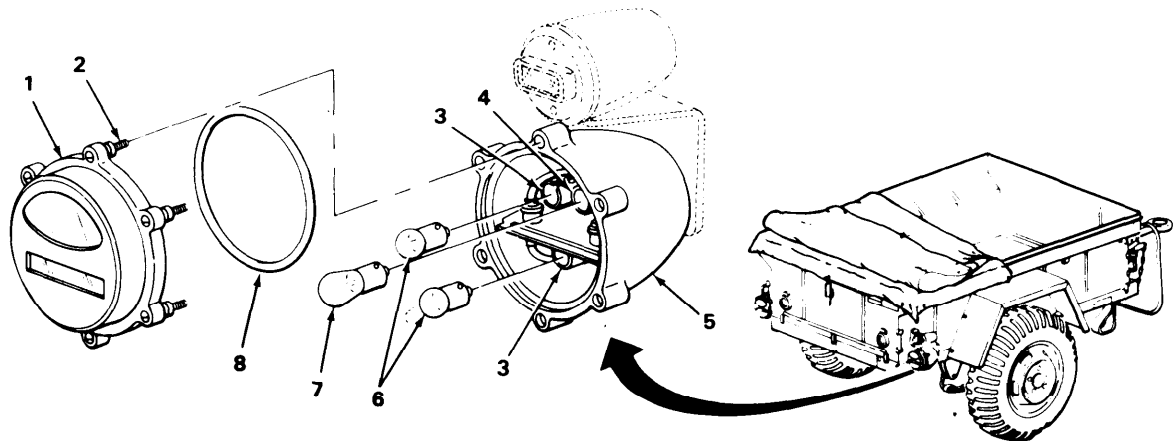

b. INSTALLATION

1. Install 2 lamps (6) in sockets (3). Install lamp (7) in socket (4).
2. If removed, install new preformed packing (8) in door assembly (1).
3. Install door assembly (1) on housing (5). Tighten 6 captive screws (2).

FOLLOW-ON TASKS:

- Connect intervehicular cable to towing vehicle (para 2-6).
- Check operation of light.

TA503903

4-19. STOPLIGHT TAILLIGHT REPLACEMENT (M416).

This Task Covers:

a. Removal

b. Installation

Initial Setup:

Equipment Conditions:

- InterVehicular cable disconnected from towing vehicle (para 2-8).

Tools/Test Equipment:

- General mechanic's tool kit

Materials/Parts:

- Marker tags (as required) (Item 11, Appendix E)
- One grommet
- Six lockwashers

a. REMOVAL

1. Tag wires for installation if identification bands are missing or not legible.
2. Remove 3 connectors (5 and 6) from clip assembly (2) and disconnect,
3. Remove grommet (4) from framerail (1), Discard grommet.
4. Pull 3 connectors (5) through hole (3).

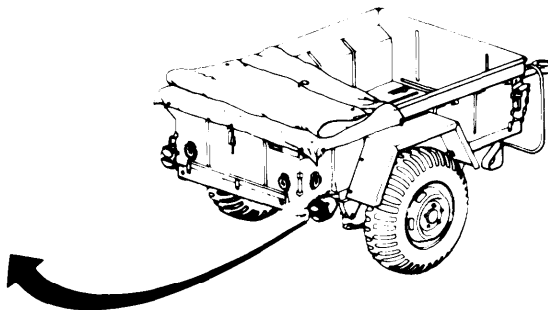
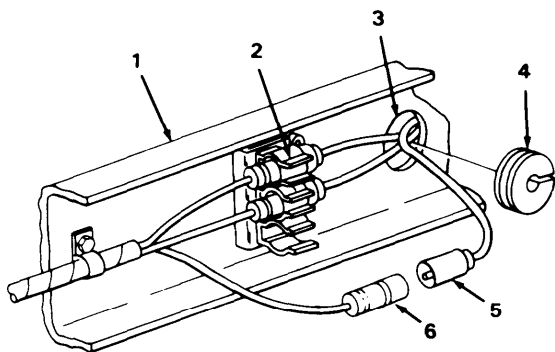

5. Remove 2 screws (8), lockwashers (9), external-tooth lockwashers (11), and stoplight taillight (12) from bracket (10). Discard lockwashers.
6. Remove 2 nuts (14), lockwashers (13), screws (7), and bracket (10) from framerail (1). Discard lockwashers.

b. INSTALLATION

1. Install bracket (10) on framerail (1) with 2 screws (7), new lockwashers (13), and nuts (14).

TA503904

4-19. STOPLIGHT TAILLIGHT REPLACEMENT (M416) (CON'T).

NOTE

To ensure proper grounding of light, external-tooth lockwashers (11) should be installed between stoplight taillight (12) and bracket (10).

2. Install stoplight taillight (12) on bracket (10) with 2 new external-tooth lockwashers (11), new lockwashers (9), and screws (8).
3. Insert 3 connectors (5) through hole (3).
4. Install new grommet (4) in framerrail (1).
5. Connect 3 connectors (5 and 6) and install in clip assembly (2).

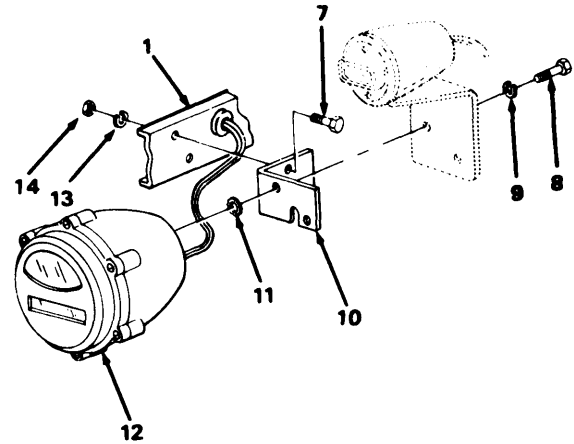
**FOLLOW-ON TASKS:**

- Connect intervehicular cable to towing vehicle (para 2-6).
- Check operation of light.

4-20. INTERVEHICULAR CABLE REPLACEMENT.

This Task Covers:

- a. Removal b. Installation

Initial Setup:

Equipment Conditions:

- Intervehicular cable disconnected from towing vehicle (para 2-8).

Tools/Test Equipment:

- General mechanic's tool kit

Materials/Parts:

- Marker tags (as required) (Item 11, Appendix E)
- Eight lockwashers

a. REMOVAL

1. Tag wires for installation if identification bands are missing or not legible.
2. Remove 4 screws (2), lockwashers (1), and cover (3) from drawbar (4), Discard lockwashers.

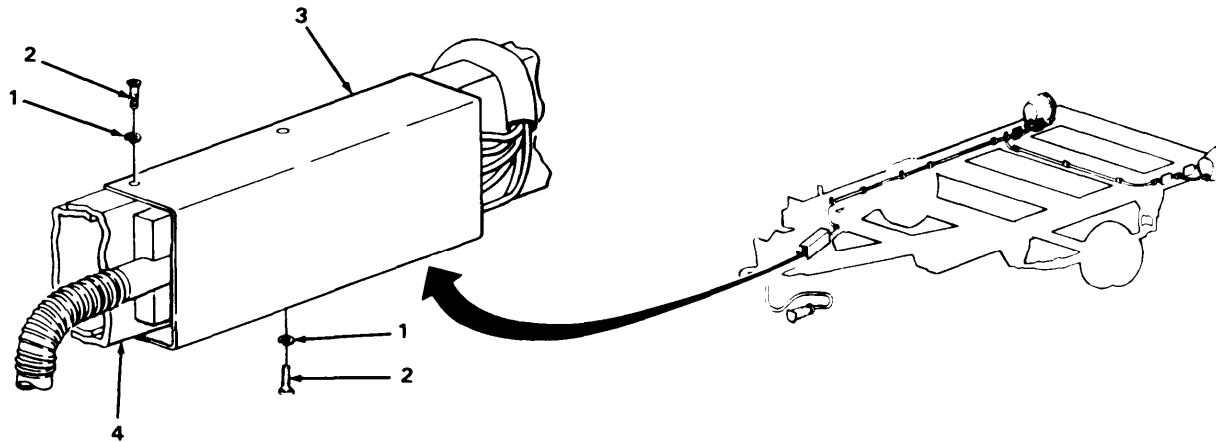

3. Remove 6 connectors (10) from 2 clip assemblies (6). Disconnect connectors.
4. Remove screw (9), lockwasher (8), and terminal (7) from clip assembly (6). Discard lockwasher.
5. Remove 2 screws (11), lockwashers (12), and strap (13) from drawbar (4). Discard lockwashers,
6. Remove nut (15), lockwasher (14), screw (17), and clamp (16) from drawbar (4). Remove intervehicular cable (5). Discard lockwashers,
7. Remove clamp (16) from intervehicular cable (5).

b. INSTALLATION

1. Install clamp (16) on intervehicular cable (5).

TA503906

4-20. INTERVEHICULAR CABLE REPLACEMENT (Con't).

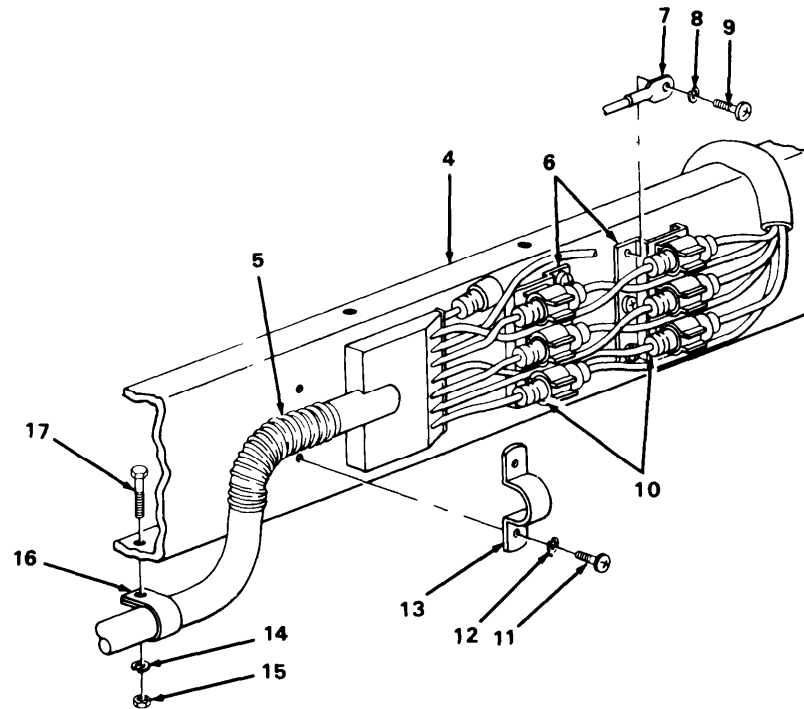

2. Install clamp (16) and intervehicular cable (5) on drawbar (4) with screw (17), new lockwasher (14), and nut (15).
3. Install strap (13) on drawbar (4) with 2 new lockwashers (12) and screws (11).
4. Connect terminal (7) to clip assembly (6) with new lockwasher (8) screw (9).
5. Connect 6 connectors (10) and insert in 2 clip assemblies (6).
6. Install cover (3) on drawbar (4) with 4 new lockwashers (1) and screws (2).

FOLLOW-ON TASKS:

- . Connect intervehicular cable to towing vehicle (para 2-6).
- Check operation of lights.

4-21. CHASSIS WIRING HARNESS REPLACEMENT.

This Task Covers:

- | | |
|------------|-----------------|
| a. Removal | b. Installation |
|------------|-----------------|

Initial Setup:

Equipment Conditions:

- Intervehicular cable disconnected from towing vehicle (para 2-8).

Tools/Test Equipment:

- General mechanic's tool kit

Materials/Parts:

- Marker tags (as required) (Item 11, Appendix E)
- Three grommets
- Four lockwashers

1. Tag wires for installation if identification bands are missing or not legible.
2. Remove 4 connectors (5) from 2 clip assemblies (4). Disconnect connectors. Repeat for opposite side.
3. Remove 4 screws (13), lockwashers (12), and cover (11) from drawbar (10). Discard lockwashers.

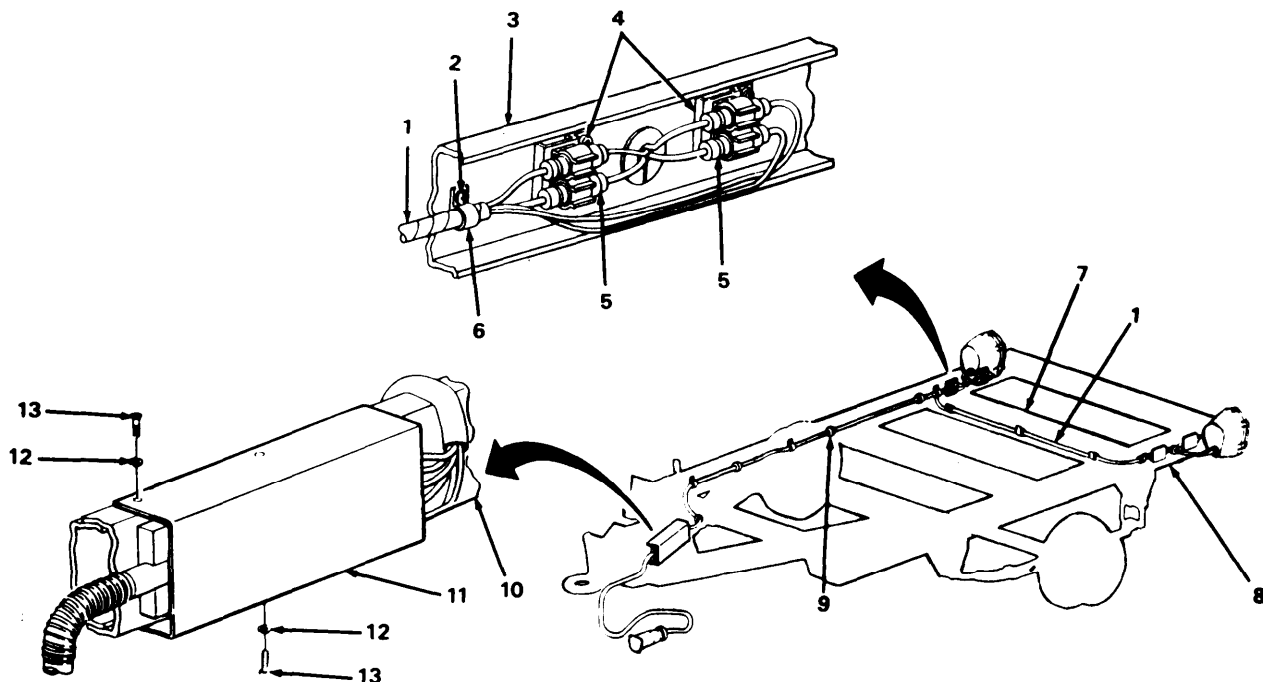

TA503908

4-21. CHASSIS WIRING HARNESS REPLACEMENT (Con't).

4. Remove 6 connectors (15) from 2 clip assemblies (14). Disconnect connectors.

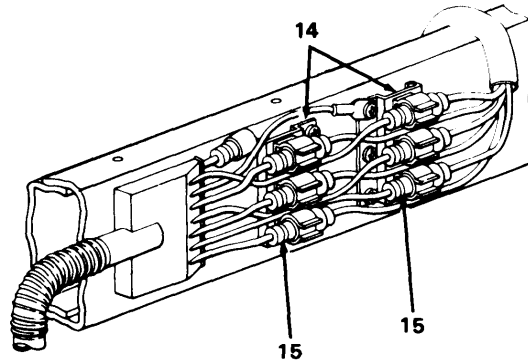

5. Remove 10 screws (2) from clamps (6) securing chassis wiring harness (1) to right framerail (3), crossmember (7), and left framerail (8).
6. Remove 10 clamps (6) from chassis wiring harness (1).
7. Remove 3 grommets (9) and discard.
8. Remove chassis wiring harness (1) from trailer.

b. INSTALLATION

1. Position chassis wiring harness (1) for installation.
2. Install 3 new grommets (9).
3. Install 10 clamps (6) on chassis wiring harness (1).
4. Secure clamps (6) to right framerail (3), crossmember (7), and left framerail (8) with 10 screws (2).
5. Connect 6 connectors (15) and insert in 2 clip assemblies (14).
6. Install cover (11) on drawbar (10) with 4 new lockwashers (12) and screws (13).
7. Connect 4 connectors (5) and insert in 2 clip assemblies (4). Repeat for opposite side.

FOLLOW-ON TASKS:

- Connect intervehicular cable to towing vehicle (para 2-6).
- Check operation of lights.

4-22. WIRING HARNESS REPAIR.

This Task Covers:

- | | |
|----------------------------|---|
| a. Male Connector Repair | c. Terminal Replacement |
| b. Female Connector Repair | d. Wire Identification Band Replacement |

Initial Setup:

Equipment Conditions:

- Intervehicular cable disconnected from towing vehicle (para 2-8).

Tools/Test Equipment:

- General mechanic's tool kit
- Common no. 2 shop set
- Electric etcher

Materials/Parts:

- Contacts (as required)
- Identification bands (as required)
- Terminals (as required)

a. MALE CONNECTOR REPAIR

1. Slide back shell (1) and remove washer (2) from wire (3).
2. Cut off and discard contact (4).
3. Remove shell (1) and discard if unserviceable.
4. Strip wire (3) to depth of new contact (4).
5. Slide shell (1) over wire (3).
6. Crimp new contact (4) onto wire (3).
7. Install washer (2) on wire (3) and slide shell (1) over washer.

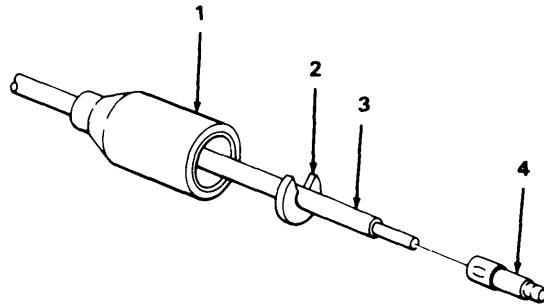

b. FEMALE CONNECTOR REPAIR

1. Slide shell (5) and insulator (6) back.
2. Cut off and discard terminal (8).
3. Slide insulator (6) and shell (5) off wire (7). Discard shell and insulator if unserviceable.
4. Strip wire (7) to depth of new terminal (8).
5. Slide shell (5) and insulator (6) over wire (7).
6. Crimp new terminal (8) onto wire (7).
7. Slide insulator (6) and shell (5) over terminal (8).

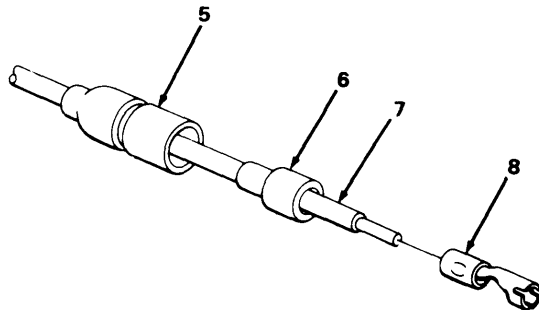

TA503910

4-22. WIRING HARNESS REPAIR (Con't).

c. TERMINAL REPLACEMENT

1. Cutoff and discard terminal (10).
2. Strip wire (9) to depth of new terminal (10).
3. Crimp new terminal (10) onto wire (9).

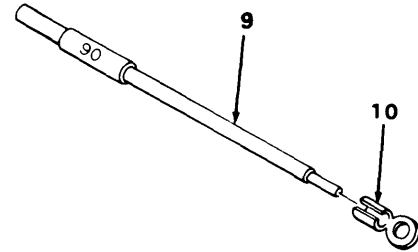

d. WIRE IDENTIFICATION BAND REPLACEMENT

1. Open tabs and remove identification band (12) from wire (11). Discard identification band.
2. Mark new identification band (12) with proper identification number. Refer to chart.
3. Position new identification band (12) over wire (11) and bend over tabs.

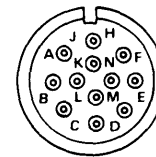
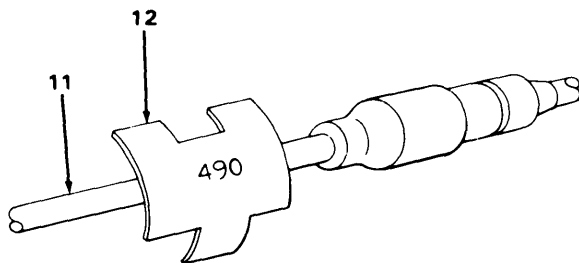

TERMINAL DESIGNATION	CIRCUIT NO.	TERMINAL DESIGNATION	CIRCUIT NO.
A	24-484	H	490
B	22-461	J	22-460
C	24-483	K	BLANK
D	90	L	BLANK
E	21-489	M	BLANK
F	23	N	BLANK

FOLLOW-ON TASKS:

- Connect intervehicular cable to towing vehicle (para 2-6).
- Check operation of lights.

4-23. WIRING DIAGRAMS.

NOTE

- This paragraph contains wiring diagrams for the M416 and M416A1 Cargo Trailers.
- Refer to these wiring diagrams when performing electrical troubleshooting and maintenance.

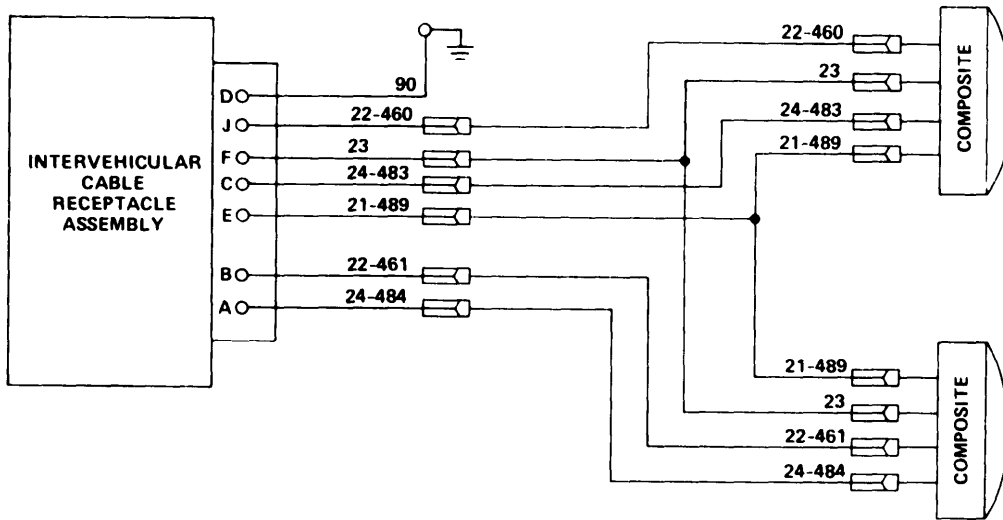

M416A1

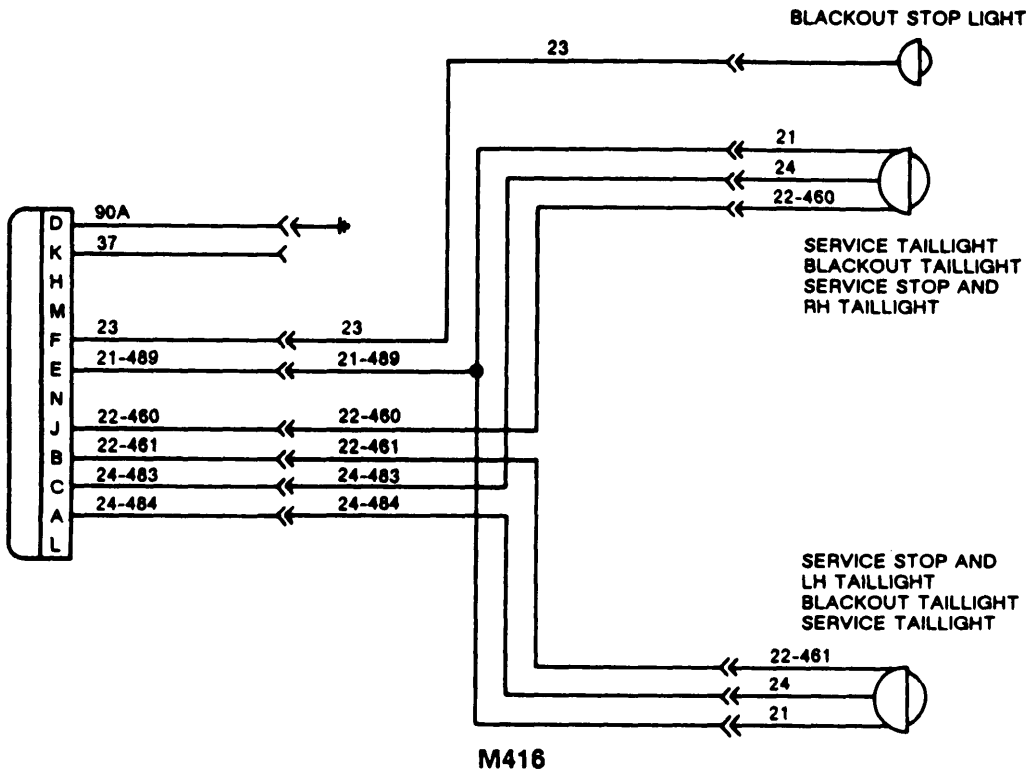

M416

TA503912

Section VII. AXLE MAINTENANCE

Paragraph Title	Page Number
Axle Replacement (M416)	4-27
Axle Replacement (M416A1)	4-29

4-24. AXLE REPLACEMENT (M416).

This Task Covers:

a. Removal

b. Installation

Initial Setup:

Equipment Conditions:

- Hubs and brakedrums removed (para 4-36).

Materials/Parts:

- Twenty lockwashers

Tools/Test Equipment:

- General mechanic's tool kit
- Floor jack

Personnel Required: Two

a. REMOVAL

1. Place a suitable floor jack under midpoint of axle (2).
2. Remove 6 nuts (10), lockwashers (9), and **screws (4) securing** backing plate (3) to axle (2). Remove backing plate. Discard lockwashers.

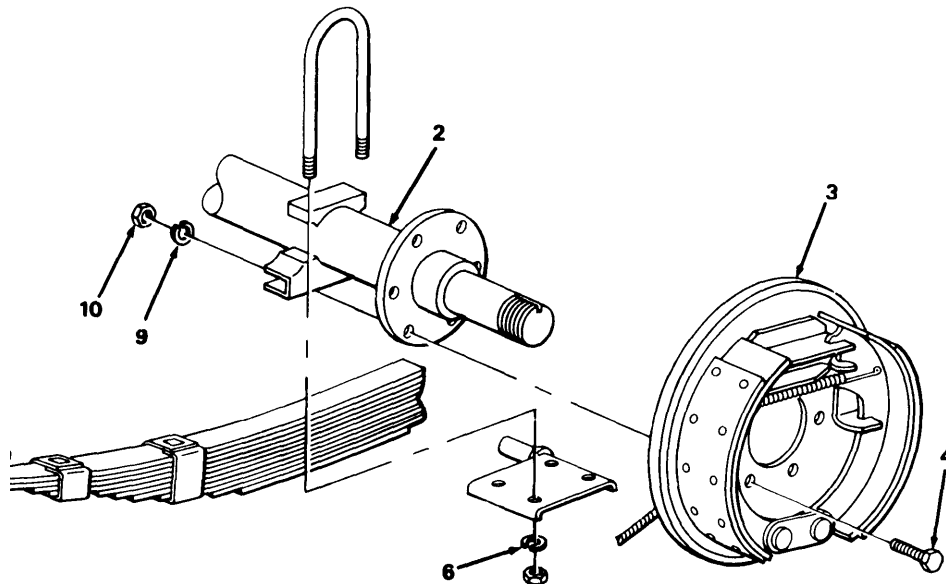

TA503913

4-24. AXLE REPLACEMENT (M416) (Con't).

3. Remove 4 nuts (5) and lockwashers (6) securing 2 U-bolts (1) to plate assembly (7). Remove U-bolts. Discard lockwashers.
4. Repeat steps 2 and 3 for opposite side.
5. Remove axle (2) from spring assemblies (8).

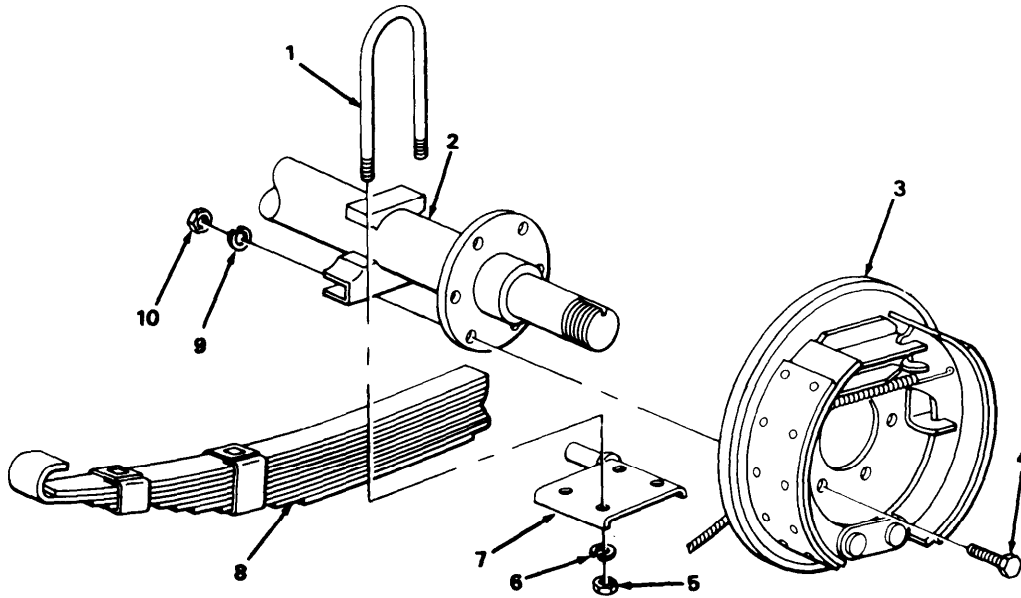

b. INSTALLATION

1. Place a suitable floor jack under midpoint of axle (2) and raise axle into position on spring assemblies (8).
2. Secure 2 U-bolts (1) to plate assembly (7) with 4 new lockwashers (6) and nuts (5).
3. Install backing plate (3) on axle (2) with 6 screws (4), new lockwashers (9), and nuts (10).
4. Repeat steps 2 and 3 for opposite side.
5. Remove floor jack.

FOLLOW-ON TASKS:

- Install hubs and brakedrums (para 4-36).

4-25. AXLE REPLACEMENT (M416A1).

This Task Covers:

a. Removal

b. Installation

Initial Setup:

Equipment Conditions:

- Hubs and brakedrums removed (para 4-37).

Tools/Test Equipment:

- General mechanic's tool kit
- Drain pan
- Floor jack

Materials/Parts:

- Rags (Item 9, Appendix E)
- Seventeen lockwashers

Personnel Required: Two

a. REMOVAL

NOTE

A suitable container should be used to catch any draining brake fluid. Ensure that all spills are cleaned up.

1. Place a suitable floor jack under midpoint of axle (4).
2. Loosen inverted nut (1) and disconnect tube assembly (3) from wheel cylinder (2).

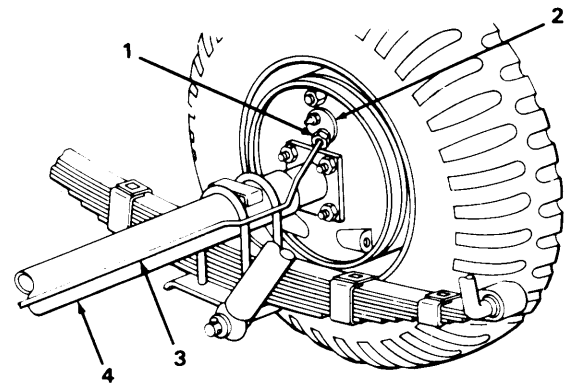

4-25. AXLE REPLACEMENT (M416A1) (Con't).

3. Remove 4 nuts (10), lockwashers (9), and screws (7) securing backing plate (6) to axle (4). Remove backing plate. Discard lockwashers.
4. Repeat steps 2 and 3 for opposite side.
5. Remove nut (16), lockwasher (15), and flatwasher (14) securing tee (17) to axle (4). Discard lockwasher.
6. Remove 2 screws (18) and clamps (19) securing tube assemblies (3) to axle (4). Remove tee (17) and tube assemblies from axle.
7. Remove 4 nuts (11) and lockwashers (12) securing 2 U-bolts (5) to plate assembly (13). Discard lockwashers.
8. Repeat step 7 for opposite side.
9. Remove axle (4) from spring assemblies (8).

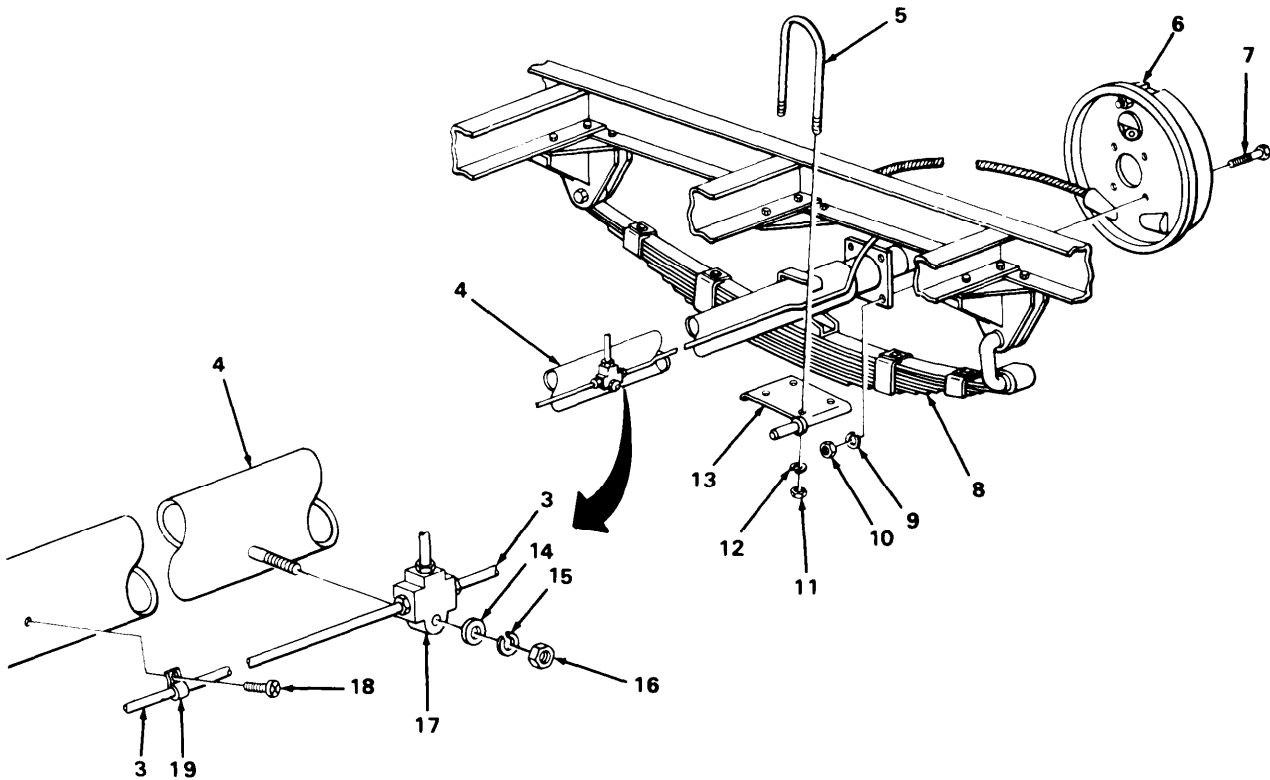

4-25. AXLE REPLACEMENT (M416A1) (Con't).

b. INSTALLATION

1. Place a suitable floor jack under midpoint of axle (4) and raise axle into position on spring assemblies (8).
2. Secure 2 U-bolts (5) to plate assembly (13) with 4 new lockwashers (12) and nuts (11).
3. Repeat step 2 for opposite side.
4. Position tee (17) and tube assemblies (3) at axle (4). Secure tube assemblies to axle with 2 clamps (19) and screws (18).
5. Secure tee (17) to axle (4) with flatwasher (14), new lockwasher (15), and nut (16).
6. Install backing plate (6) on axle (4) with 4 screws (7), new lockwashers (9), and nuts (10).
7. Connect tube assembly (3) to wheel cylinder (2) and tighten inverted nut (1).
8. Repeat steps 6 and 7 for opposite side.
9. Remove floor jack.

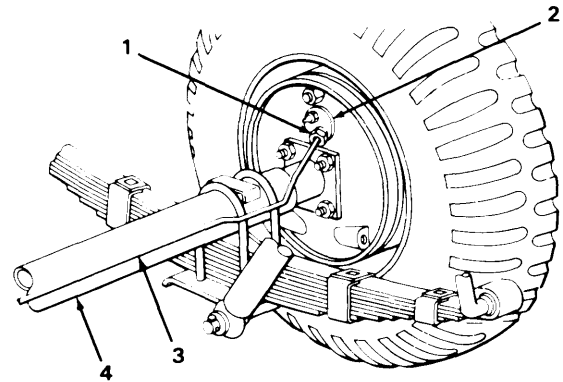

FOLLOW-ON TASKS:

- Install hubs and brakedrums (para 4-37).
- Bleed brakes (para 4-33).

Section VIII. BRAKE SYSTEM MAINTENANCE

Paragraph Title	Page Number
Bleeding Hydraulic Brake System (M416A1)	4-49
Brakeshoe Adjustment (M416)	4-39
Brakeshoe Adjustment (M416A1)	4-40
Brakeshoe Replacement (M416)	4-41
Brakeshoe Replacement (M416A1)	4-44
Handbrake Cable Assembly Replacement	4-34
Handbrake Lever Replacement	4-32
Hydraulic Brake Lines, Hoses, and Fittings Replacement (M416A1)	4-51
Master Cylinder Replacement (M416A1)	4-57
Wheel Cylinder Replacement (M416A1)	4-48

4-26. HANDBRAKE LEVER REPLACEMENT.

This Task Covers:

a. **Removal**

b. **Installation**

Initial Setup:

Materials/Parts:

- One cotter pin
- Two locknuts
- Two lockwashers

Tools/Test Equipment:

- General mechanic's tool kit
- Floor jack

WARNING

If trailer is not coupled to towing vehicle, ensure that wheels are securely chocked. Failure to do so may cause trailer to roll, resulting in injury to personnel or damage to equipment.

1. Remove cotter pin (12), flatwasher (n), and pin (3) and disconnect clevis (2) from handbrake lever (1). Discard cotter pin.
2. Remove 2 nuts (7), lockwashers (6), and screws (10) securing handbrake lever (1) to bracket (4). Remove handbrake lever. Discard lockwashers.
3. Remove 2 locknuts (5) and U-bolt (9) securing bracket (4) to crossmember (8), Remove bracket. Discard locknuts.

4-26. HANDBRAKE LEVER REPLACEMENT (Con't).

b. INSTALLATION

WARNING

If trailer is not coupled to towing vehicle, ensure that wheels are securely chocked. Failure to do so may cause trailer to roll, resulting in injury to personnel or damage to equipment.

1. Install bracket (4) on crossmember (8) with U-bolt (9) and 2 new locknuts (5).
2. Install handbrake lever (1) on bracket (4) with 2 screws (10), new lockwashers (6), and nuts (7).
3. Connect clevis (2) to handbrake lever (1) with pin (3), flatwasher (11), and new cotter pin (12).

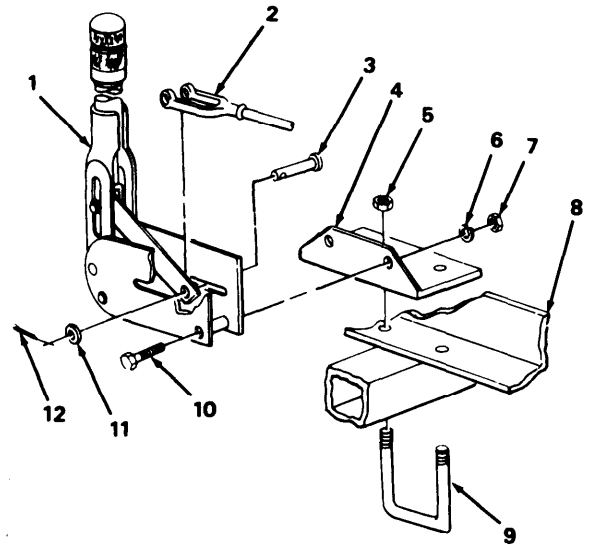

FOLLOW-ON TASKS:

- Lubricate handbrake lever (Chapter 3, Section 1).
- Adjust handbrake lever (para 3-6).

4-27. HANDBRAKE CABLE ASSEMBLY REPLACEMENT.

This Task Covers:

- a. Removal b. Installation
-

Initial Setup:

Equipment Conditions:

- Hubs and brakedrums removed (M416A1) (para 4-37).

Tools/Test Equipment:

- General mechanic's tool kit

Materials/Parts:

M416:

- Five cotter pins
- Six lockwashers

M416A1:

- Three cotter pins
 - Four lockwashers
-

a. REMOVAL

WARNING

if trailer is not coupled to towing vehicle, ensure that wheels are securely chocked. Failure to do so may cause trailer to roll, resulting in injury to personnel or damage to equipment.

1. Remove cotter pin (8), flatwasher (7), and pin (6) and disconnect clevis (2) from handbrake lever (1). Discard cotter pin.
2. Remove cotter pin (5) and connecting link (3) with clevis (2) from bell crank (4). Discard cotter pin.

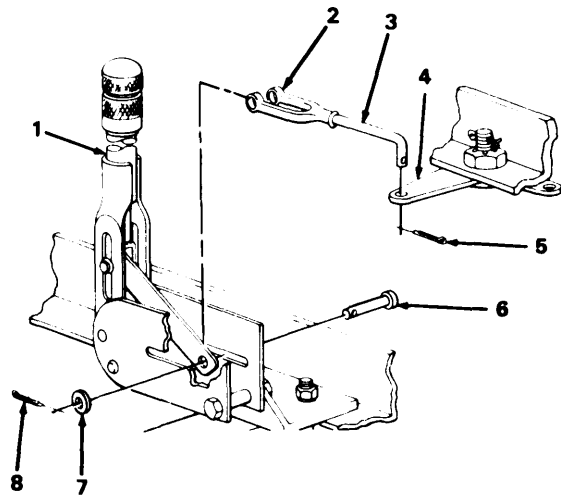

3. Remove cotter pin (9), slotted nut (10), and shoulder bolt (22) securing bell crank (4) to crossmember (11). Remove bell crank from crossmember and adjusting rod (21). Discard cotter pin.

TA503919

4-27. HANDBRAKE CABLE ASSEMBLY REPLACEMENT (Con't).

4. Remove 2 nuts (13) from adjusting rod (21). Remove adjusting rod and cable nut (1 2). Leave cable nut on adjusting rod.
5. Remove equalizer (20) from handbrake cable assembly (19).
6. Remove 2 nuts (15), lockwashers (16), and bolts (18) securing strap (17) to crossmember (14). Remove strap. Discard lockwashers.
7. Repeat step 6 for opposite side.

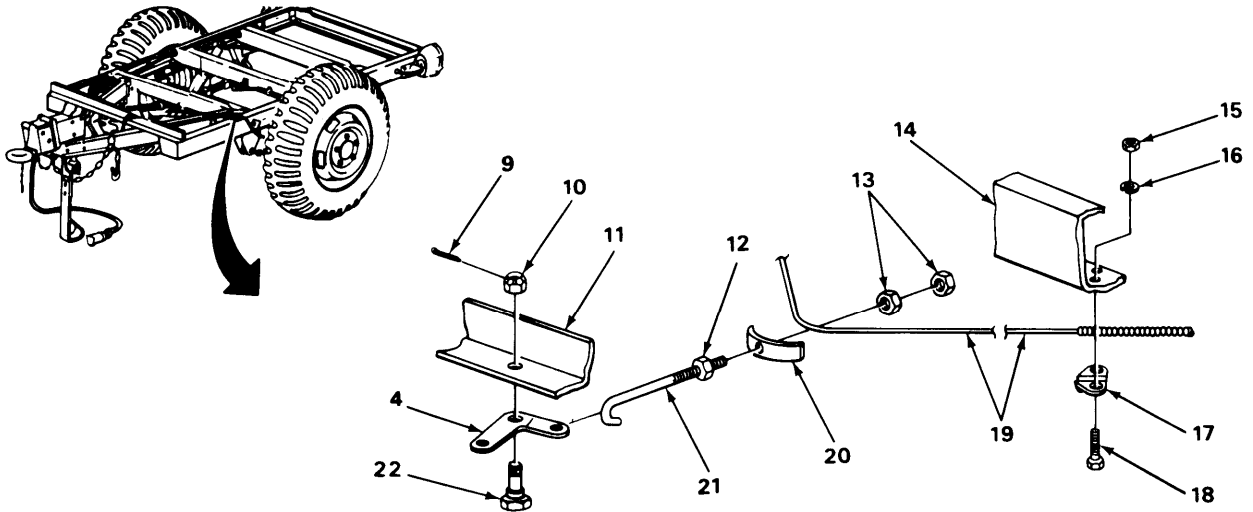

NOTE

Steps 8 through 10 are for M416 only.

8. Remove cotter pin (23) and pin (25) and disconnect handbrake cable assembly (19) from pawl (24). Discard cotter pin.
9. Remove nut (28), lockwasher (27), and screw (26) securing handbrake cable assembly (19) to backing plate (29). Remove handbrake cable assembly. Discard lockwasher.
10. Repeat steps 8 and 9 for opposite side.

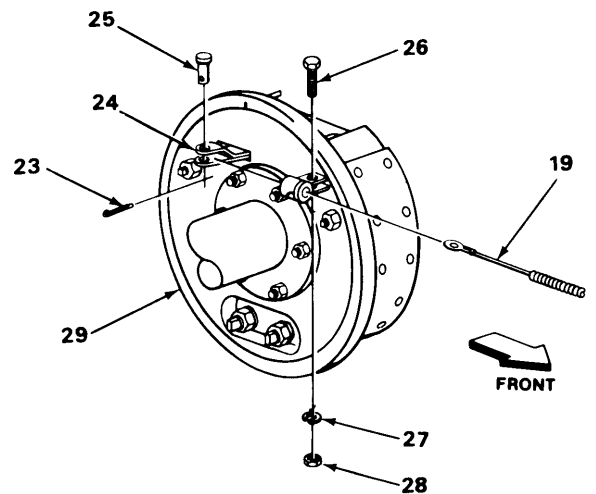

TA503920

4-27. HANDBRAKE CABLE ASSEMBLY REPLACEMENT (Con't).

NOTE

Steps 11 through 13 are for M416A1 only.

11. Unhook handbrake cable assembly (19) from lever (30).
12. Remove handbrake cable assembly (19) from backing plate (29).
13. Repeat steps 11 and 12 for opposite side.

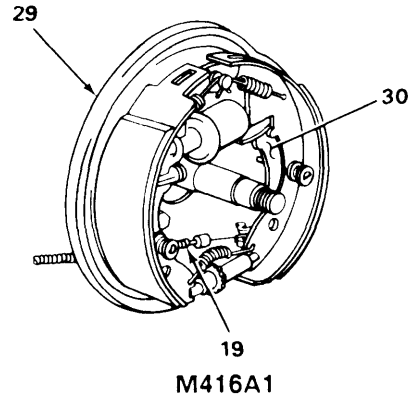

b. INSTALLATION

WARNING

If trailer is not coupled to towing vehicle, ensure that wheels are securely chocked. Failure to do so may cause trailer to roll, resulting in injury to personnel or damage to equipment.

NOTE

Steps 1 through 3 are for M416A1 only.

1. Thread handbrake cable assembly (19) through backing plate (29).
2. Connect handbrake cable assembly (19) to lever (30).
3. Repeat steps 1 and 2 for opposite side.

NOTE

Steps 4 through 6 are for M416 only.

4. Install handbrake cable assembly (19) on backing plate (29) with screw (26), new lockwasher (27), and nut (28).
5. Connect handbrake cable assembly (19) to pawl (24) with pin (25) and new cotter pin (23).
6. Repeat steps 4 and 5 for opposite side.

4-27. HANDBRAKE CABLE ASSEMBLY REPLACEMENT (Con't).

7. Install handbrake cable assembly (19) on crossmember (14) with strap (17), 2 bolts (18), new lockwashers (16), and nuts (15).
8. Repeat step 7 for opposite side.

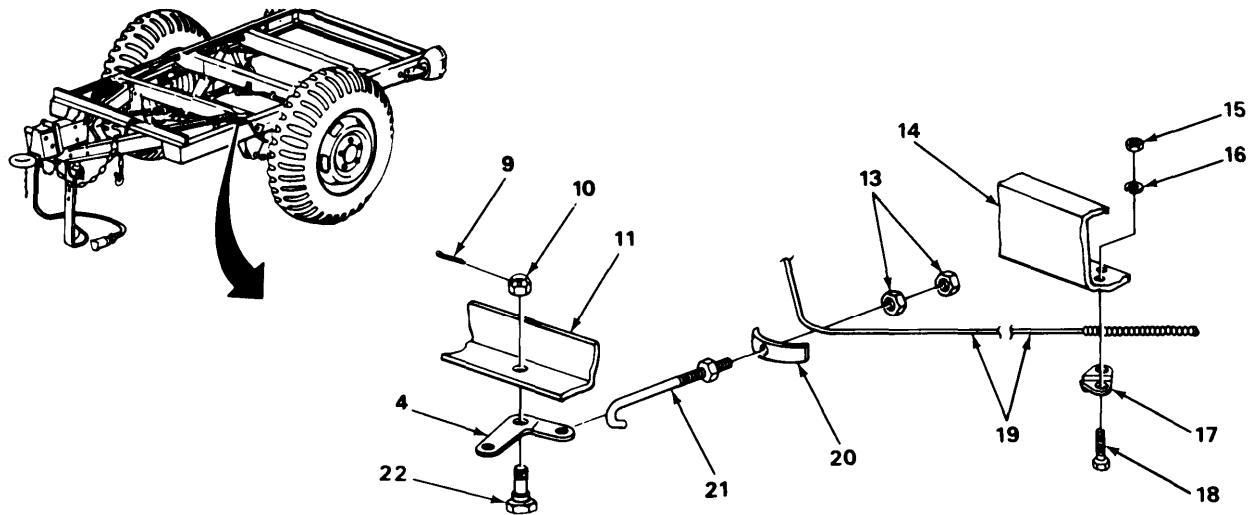

9. Install adjusting rod (21) and equalizer (20) on handbrake cable assembly (19) with 2 nuts (13).
10. Connect bell crank (4) to adjusting rod (21).
11. Install bell crank (4) on crossmember (11) with shoulder bolt (22), slotted nut (10), and new cotter pin (9) .

4-27. HANDBRAKE CABLE ASSEMBLY REPLACEMENT (Con't).

12. Secure connecting link (3) with clevis (2) to bell crank (4) with new cotter pin (5).
13. Connect clevis (2) to handbrake lever (1) with pin (6), flatwasher (7), and new cotter pin (8).

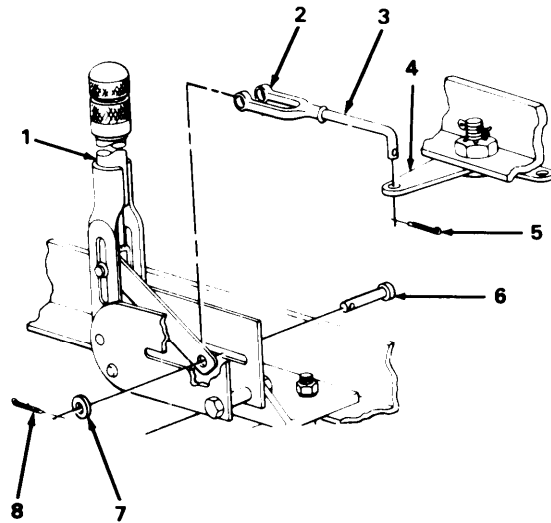

FOLLOW-ON TASKS:

- Install hubs and brakedrums (M416A1) (para 4-37).
- Lubricate handbrake bell crank and cable assembly retaining straps (Chapter 3, Section 1).
- Adjust handbrake lever (para 3-6).

4-28. BRAKESHOE ADJUSTMENT (M416).

This Task Covers: Adjustment

Initial Setup:

Tools/Test Equipment:

- General mechanic's tool kit
 - Floor jack
-

ADJUSTMENT

NOTE

Procedure given is for 1 wheel. Procedure for opposite side is the same.

1. Position floor jack under end of axle (1) and raise until wheel (2) is off ground.
2. Turn pin (5) on backing plate (3) counterclockwise until wheel just locks.
3. Back off pin (5) until wheel just turns freely.
4. Turn pin (4) clockwise until wheel just locks.
5. Back off pin (4) until wheel just turns freely.
6. Lower wheel (2) to ground. Remove floor jack.

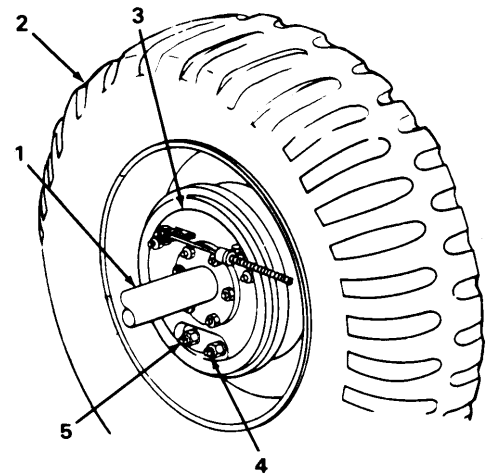

FOLLOW-ON TASKS:

- Adjust handbrake lever (para 3-6).

4-29. BRAKESHOE ADJUSTMENT (M416A1).

This Task Covers: Adjustment

Initial Setup:

Tools/Test Equipment:

- General mechanic's tool kit
- Common no. 1 shop set
- Brakeshoe adjusting tool
- Floor jack

ADJUSTMENT

NOTE

- To ensure that brake adjustment is accurate, adjustment should be performed when brakedrums are cool.
- Procedure given is for 1 wheel. Procedure for opposite side is the same.

1. Position floor jack under end of axle (1) and raise until wheel (3) is off ground.
2. Remove cover (5) from backing plate (2).
3. Turn adjuster (4) downward until wheel just locks. Back off until wheel just turns freely.
4. Install cover (5) in backing plate (2).
5. Lower wheel (3) to ground. Remove floor jack.

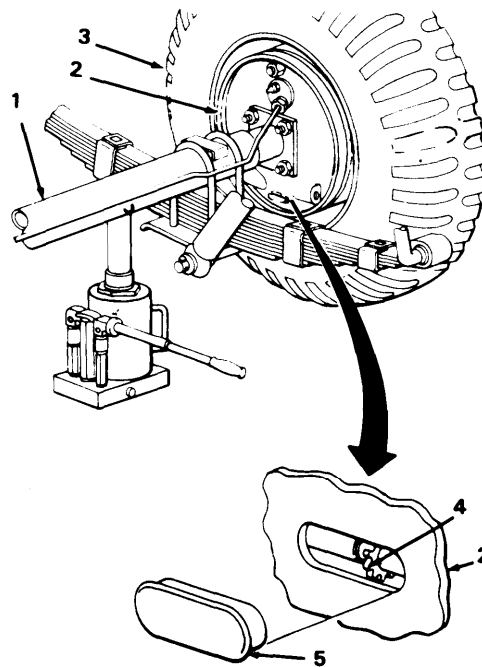

FOLLOW-ON TASKS:

- Adjust handbrake lever (para 3-6).

TA503925

4-30. BRAKESHOE REPLACEMENT (M416).

This Task Covers:

- a. Removal
 - b. Cleaning and Inspection
 - c. Installation
-

Initial Setup:

Equipment Conditions:

- Hub and brakedrum removed (para 4-36).

Tools/Test Equipment:

- General mechanic's tool kit
- Common no. 1 shop set
- Brake repair pliers

Materials/Parts:

- Dry cleaning solvent (Item 10, Appendix E)
 - Two cotter pins
 - Two lockwashers
-

a. REMOVAL

WARNING

DO NOT handle brakeshoes, brakedrums, or other brake components unless area has been properly cleaned. There may be asbestos dust on these components which can be dangerous if you touch it or breathe it. Wear an approved filter mask and gloves. Never use compressed air or a dry brush to clean brake components. Dust may be removed using an industrial-type vacuum cleaner. Clean dust or mud away from brake components with water and a wet, soft brush or cloth. Failure to follow this warning may result in serious illness or death to personnel.

4-30. BRAKESHOE REPLACEMENT (M416) (Con't).

1. Remove cotter pin (16) and pin (2) securing handbrake cable assembly (1) to pawl (4). Discard cotter pin.
2. Remove spring (8) from brakeshoes (7 and 12).
3. Remove 2 nuts (14) and lockwashers (13) securing 2 anchor pins (9) to backing plate (5). Remove anchor pins, plate (10), and 2 cams (11). Discard lockwashers.

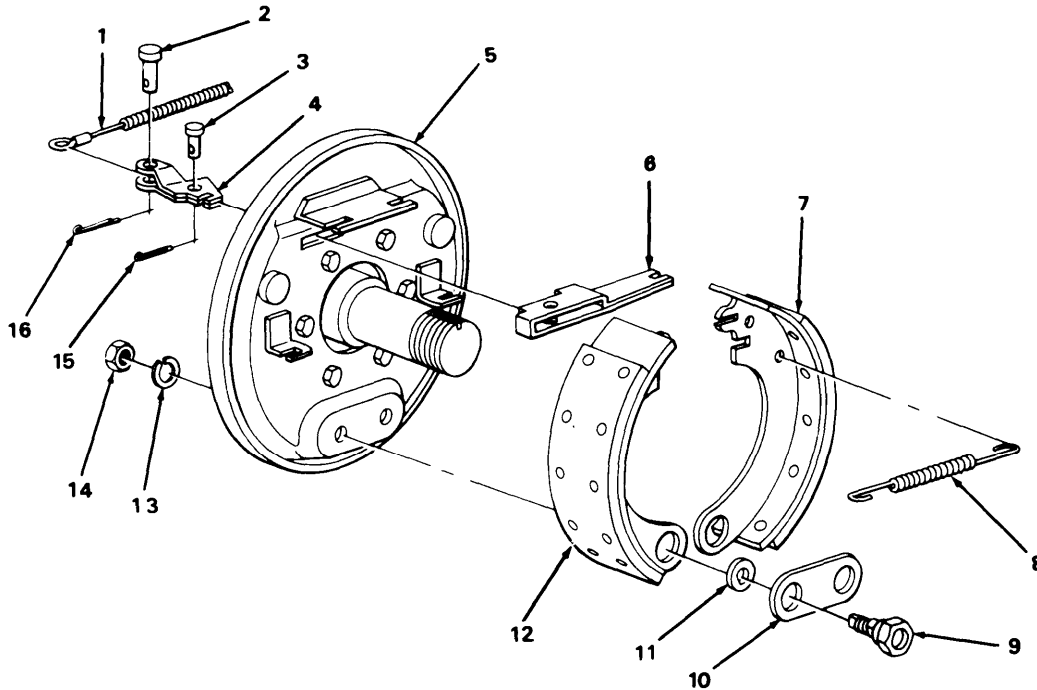

4. Remove brakeshoe (7) from backing plate (5).
5. Remove strut (6) from backing plate (5).
6. Remove cotter pin (15) and pin (3) securing pawl (4) to strut (6). Remove pawl. Discard cotter pin,
7. Remove brakeshoe (12) from backing plate (5).

b. CLEANING AND INSPECTION

WARNING

DO NOT handle brakeshoes, brakedrums, or other brake components unless area has been properly cleaned. There may be asbestos dust on these components which can be dangerous if you touch it or breathe it. Wear an approved filter mask and gloves. Never use compressed air or a dry brush to clean brake components. Dust may be removed using an industrial-type vacuum cleaner. Clean dust or mud away from brake components with water and a wet, soft brush or cloth. Failure to follow this warning may result in serious illness or death to personnel.

TA503926

4-30. BRAKESHOE REPLACEMENT (M416) (Con't).

WARNING

Dry cleaning solvent P-D-680 is toxic and flammable. Always wear protective goggles and gloves, and use only in a well-ventilated area. Avoid contact with skin, eyes, and clothes, and DO NOT breathe vapors. DO NOT use near open flame or excessive heat. The solvent's flash point is 100°F-130°F (38°C-59°C). If you become dizzy while using cleaning solvent, immediately get fresh air and medical help. If solvent contacts eyes, immediately wash your eyes and get medical aid.

1. Clean all parts with dry cleaning solvent. Dry thoroughly.
2. inspect brakeshoes for cracks.
3. Inspect linings (18) for cracks or looseness.
4. Inspect rivets (17) for looseness. Rivets should be at least 1/16 in. (1.6 mm) below surface of lining (18).
5. Measure thickness of linings (18). Minimum thickness is 1/8 in. (3.2 mm).
6. If brakeshoes are worn, send to direct support maintenance for repair.

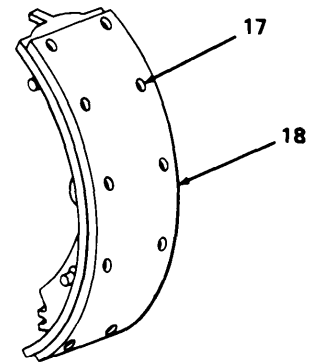

c. INSTALLATION

1. Position brakeshoe (12) on backing plate (5).
2. Install pawl (4) on strut (6) with pin (3) and new cotter pin (15).
3. Position strut (6) and brakeshoe (7) on backing plate (5).
4. Install 2 cams (11), plate (10), and 2 anchor pins (9) on backing plate (5) with 2 new lockwashers (13) and nuts (14).
5. install spring (8) on brakeshoes (7 and 12).
6. Connect handbrake cable assembly (1) to pawl (4) with pin (2) and new cotter pin (16).

FOLLOW-ON TASKS:

- Install hub and brakedrum (para 4-36).
- Adjust brakes (para 4-28).

4-31. BRAKESHOE REPLACEMENT (M416A1).

This Task Covers:

- a. Removal
- b. Cleaning and Inspection
- c. Installation

Initial Setup:

Equipment Conditions:

- Hub and brakedrum removed (para 4-37).

Tools/Test Equipment:

- General mechanic's tool kit
- Common no, 1 shop set
- Brake repair pliers
- Brake retaining hold down spring tool

Materials/Parts:

- Dry cleaning solvent (Item 10, Appendix E)
- One retainer

a. REMOVAL

WARNING

DO NOT handle brakeshoes, brakedrums, or other brake components unless area has been properly cleaned. There may be asbestos dust on these components which can be dangerous if you touch it or breathe it. Wear an approved filter mask and gloves. Never use compressed air or a dry brush to clean brake components. Dust may be removed using an industrial-type vacuum cleaner. Clean dust or mud away from brake components with water and a wet, soft brush or cloth. Failure to follow this warning may result in serious illness or death to personnel.

1. Remove 2 springs (4) from brakeshoes (1 and 3) and anchor pin (2).
2. Remove guide plate (9) from anchor pin (2).
3. Remove adjusting screw spring (15) from brakeshoes (1 and 3).
4. Remove adjuster (14).
5. Using brake retaining hold down spring tool, remove two seats (16) and spring (17).
6. Remove brakeshoe (1) from backing plate (6).
7. Remove hold down pin (19).
8. Remove strut (12) from brakeshoe (3). Remove spring (13) from strut.
9. Using brake retaining hold down spring tool, remove 2 seats (10) and spring (11).

4-31. BRAKESHOE REPLACEMENT (M416A1) (Con't).

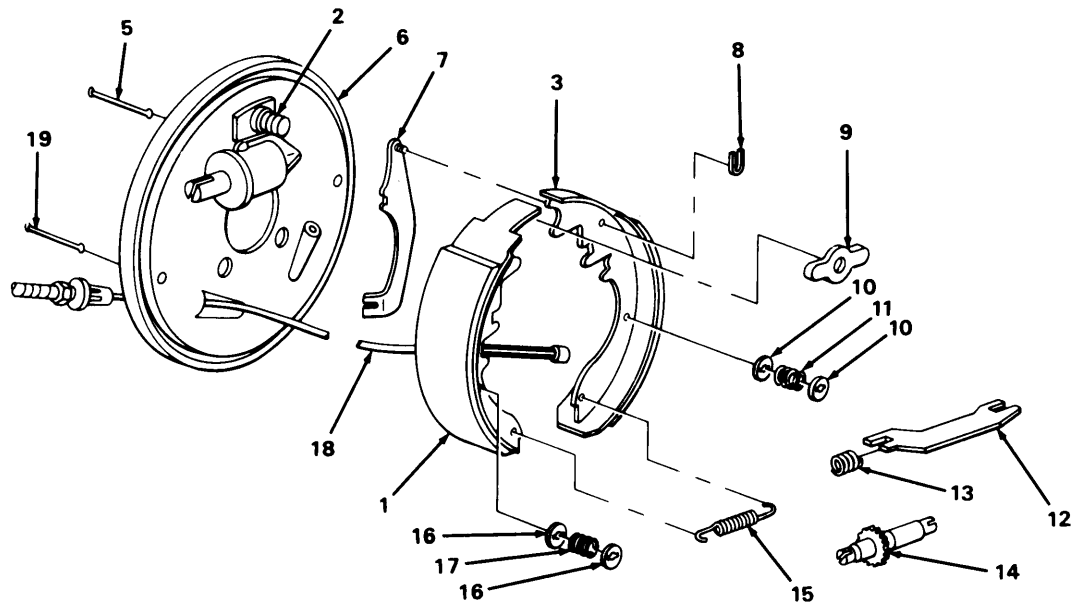
**NOTE**

Handbrake cable assembly (18) and handbrake lever (7) will still be attached to brakeshoe (3).

10. Remove brakeshoe (3) from backing plate (6).
11. Remove hold down pin (5).
12. Disconnect handbrake cable assembly (18) from handbrake lever (7).
13. Remove retainer (8) and handbrake lever (7) from brakeshoe (3). Discard retainer.

4-31. BRAKESHOE REPLACEMENT (M416A1) (Con't).

b. CLEANING AND INSPECTION

WARNING

- **DO NOT** handle brakeshoes, brakedrums, or other brake components unless area has been properly cleaned. There may be asbestos dust on these components which can be dangerous if you touch it or breathe it. Wear an approved filter mask and gloves. Never use compressed air or a dry brush to clean brake components. Dust may be removed using an industrial-type vacuum cleaner. Clean dust or mud away from brake components with water and a wet, soft brush or cloth. Failure to follow this warning may result in serious illness or death to personnel.
 - **Dry cleaning solvent P-D-680 is toxic and flammable. Always wear protective goggles and gloves, and use only in a well-ventilated area. Avoid contact with skin, eyes, and clothes, and DO NOT breathe vapors. DO NOT use near open flame or excessive heat. The solvent's flash point is 100°F-130°F (38°C-59°C). If you become dizzy while using cleaning solvent, immediately get fresh air and medical help. If solvent contacts eyes, immediately wash your eyes and get medical aid.**
1. Clean all parts with dry cleaning solvent. Dry thoroughly.
 2. Inspect brakeshoes for cracks.
 3. Inspect linings for cracks or looseness.
 4. Measure thickness of linings. Minimum thickness is 1/8 in. (3,2 mm).
 5. If brakeshoes are damaged, or linings are worn or damaged, replace brakeshoes.

c. INSTALLATION

1. Install handbrake lever (7) on brakeshoe (3) with new retainer (8).
2. Connect handbrake cable assembly (18) to handbrake lever (7),
3. Position hold down pin (5) and brakeshoe (3) at backing plate (6).
4. Using brake retaining hold down spring tool, install 2 seats (10) and spring (11).
5. Install spring (13) on strut (12) and position strut on brakeshoe (3).
6. Position hold down pin (19) and brakeshoe (1) at backing plate (6).
7. Using brake retaining hold down spring tool, install 2 seats (16) and spring (17),
8. Install adjuster (14) and adjusting screw spring (15).
9. Install guide plate (9) on anchor pin (2).

4-31. BRAKESHOE REPLACEMENT (M416A1) (Con't).

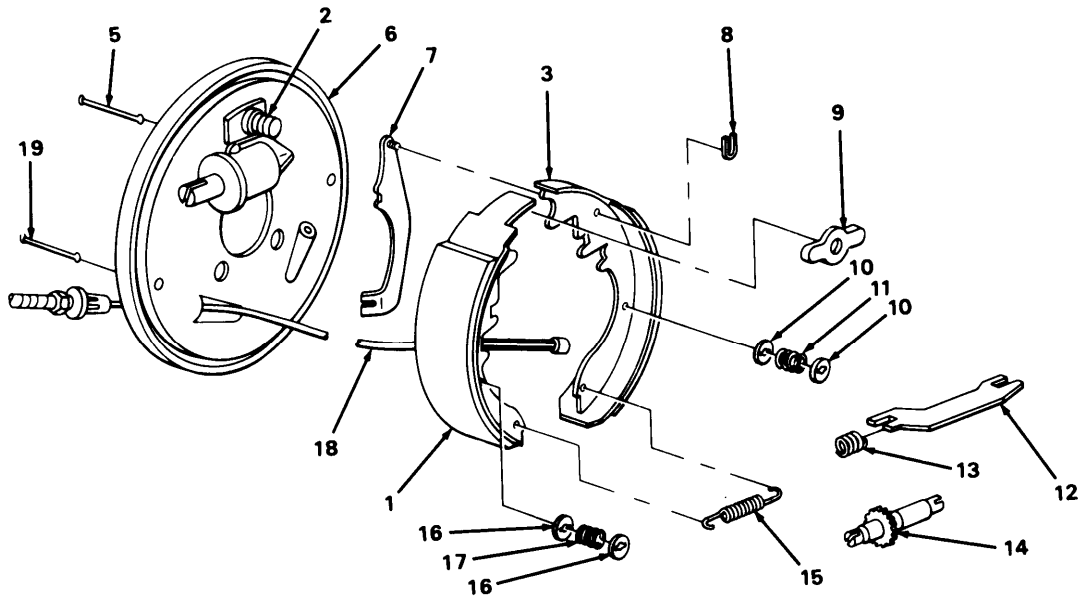

10. Install 2 springs (4) on brakeshoes (1 and 3) and anchor pin (2).

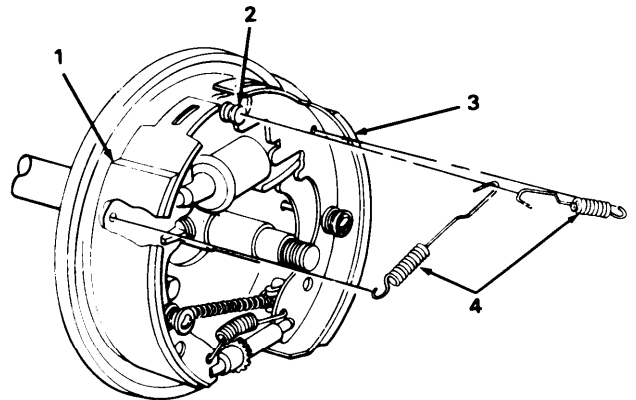

FOLLOW-ON TASKS:

- Install hub and brakedrum (para 4-37).
- Adjust brakes (para 4-29).

4-32. WHEEL CYLINDER REPLACEMENT (M416A1).

This Task Covers:

- | | |
|------------|-----------------|
| a. Removal | b. Installation |
|------------|-----------------|

Initial Setup:

Equipment Conditions:

- Brakeshoe removed (para 4-31).

Tools/Test Equipment:

- General mechanic's tool kit
- Drain pan

Materials/Parts:

- Rags (Item 9, Appendix E)

a. REMOVAL

NOTE

A suitable container should be used to catch any draining brake fluid. Ensure that all spills are cleaned up.

1. Loosen inverted nut (1) and disconnect tube assembly (2) from wheel cylinder (5).
2. Remove 2 screws (3) and wheel cylinder (5) from backing plate (4).

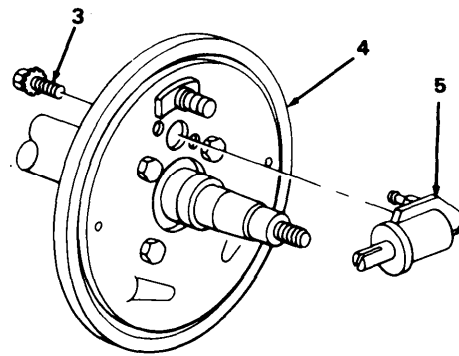
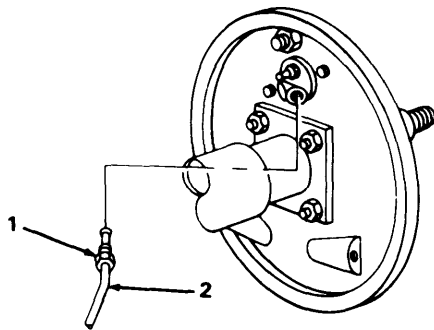

b. INSTALLATION

1. Install wheel cylinder (5) on backing plate (4) with 2 screws (3).
2. Connect tube assembly (2) to wheel cylinder (5) and tighten inverted nut (1).

FOLLOW-ON TASKS:

- Install brakeshoe (para 4-31).
- Bleed brakes (para 4-33).

TA503931

4-33. BLEEDING HYDRAULIC BRAKE SYSTEM (M416A1).

This Task Covers:

- | | |
|--------------------|----------------------|
| a. Manual Bleeding | b. Pressure Bleeding |
|--------------------|----------------------|

Initial Setup:

Materials/Parts:

- Brake fluid (Item 2, Appendix E)
- Rags (Item 9, Appendix E)
- One locknut
- Plastic tubing

Personnel Required: Two

References:

- TB 43-0002-87
- TM 9-4910 -709-14&P

Tools/Test Equipment:

- General mechanic's tool kit
- Common no. 1 shop set
- Drain pan
- Pressure bleeder
- Quart container

a. MANUAL BLEEDING

NOTE

- This procedure is typical for both left and right wheels.
 - Manual bleeding procedure should be used only if a pressure bleeder is not available.
 - Fluid level of master cylinder (2) should be checked frequently during bleeding procedure and fluid added as required. Failure to keep master cylinder filled will allow air to enter hydraulic brake system.
 - A suitable container should be used to catch any draining brake fluid. Ensure that all spills are cleaned up.
1. Remove locknut (1) and screw (5) securing shock absorber (4) to channel assembly (3). Discard locknut.

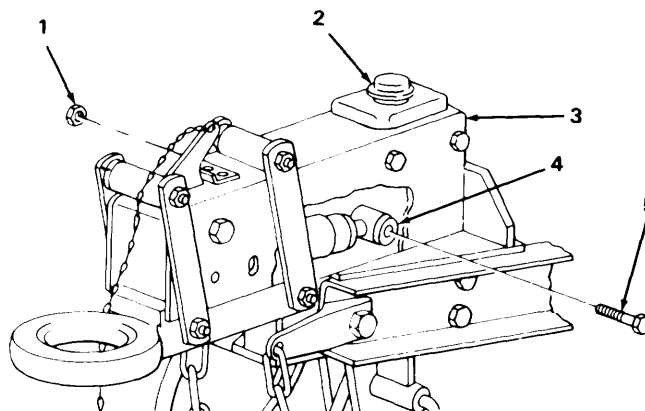

TA503932

4-33. BLEEDING HYDRAULIC BRAKE SYSTEM (M416A1) (Con't).

2. Connect plastic tubing (6) to bleed fitting (7) on wheel cylinder. Plastic tubing should be long enough to reach ground when connected.
3. Fill container (8) 1/2 full with brake fluid and position by wheel being bled, Submerge free end of plastic tubing (6) in brake fluid.

NOTE

- Assistant should pump actuator slowly while brakes are bled.
- Ensure that free end of plastic tubing (6) stays submerged in brake fluid.

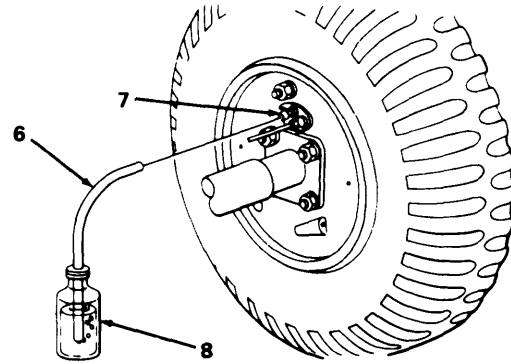

4. Open bleed fitting (7) 3/4 of a turn. Brake fluid and air will be forced through plastic tubing. Continue until no more air bubbles appear in brake fluid.
5. Close bleed fitting (7) and disconnect plastic tubing (6).
6. Repeat steps 2 through 5 for other wheel.
7. Install screw (5) and new locknut (1) to secure shock absorber (4) to channel assembly (3).

b. PRESSURE BLEEDING

NOTE

- Fluid level of master cylinder (2) should be checked frequently during bleeding procedure and fluid added as required. Failure to keep master cylinder filled will allow air to enter the hydraulic brake system.
- A suitable container should be used to catch any draining brake fluid. Ensure that all spills are cleaned up.

1. Connect pressure bleeder to master cylinder (2) and operate in accordance with instructions in TM 9-4910-709-14&P.
2. Bleed hydraulic brake system by performing MANUAL BLEEDING, steps 2 through 6.

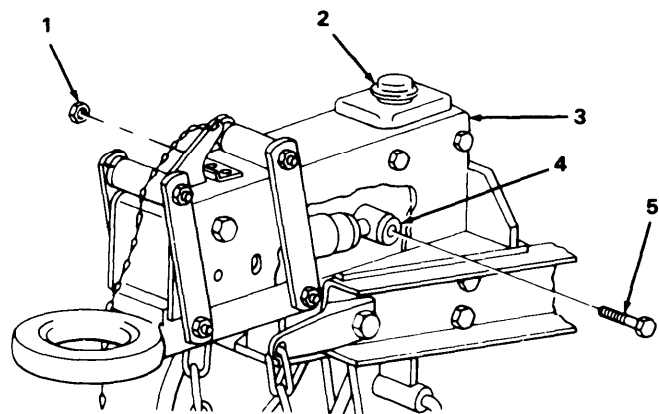

TA503933

4-34. HYDRAULIC BRAKE LINES, HOSES, AND FITTINGS REPLACEMENT (M416A1).

This Task Covers:

- | | |
|---|--|
| a. Tube Assembly Removal, Master Cylinder to Coupling | e. Axle Tube Assembly Installation |
| b. Tube Assembly Removal, Coupling to Hose Assembly | f. Hose Assembly Installation |
| c. Hose Assembly Removal | g. Tube Assembly Installation, Coupling to Hose Assembly |
| d. Axle Tube Assembly Removal | h. Tube Assembly Installation, Master Cylinder to Coupling |

Initial Setup:

Materials/Parts:

- Rags (Item 9, Appendix E)
- One gasket
- One lockwasher

Tools/Test Equipment:

- General mechanic's tool kit
- Drain pan

a. TUBE ASSEMBLY REMOVAL, MASTER CYLINDER TO COUPLING

NOTE

A suitable container should be used to catch any draining brake fluid. Ensure that all spills are cleaned up.

1. Loosen inverted nut (14) and disconnect tube assembly (5) from master cylinder (1).
2. Loosen inverted nut (4) and disconnect tube assembly (5) from coupling (3).

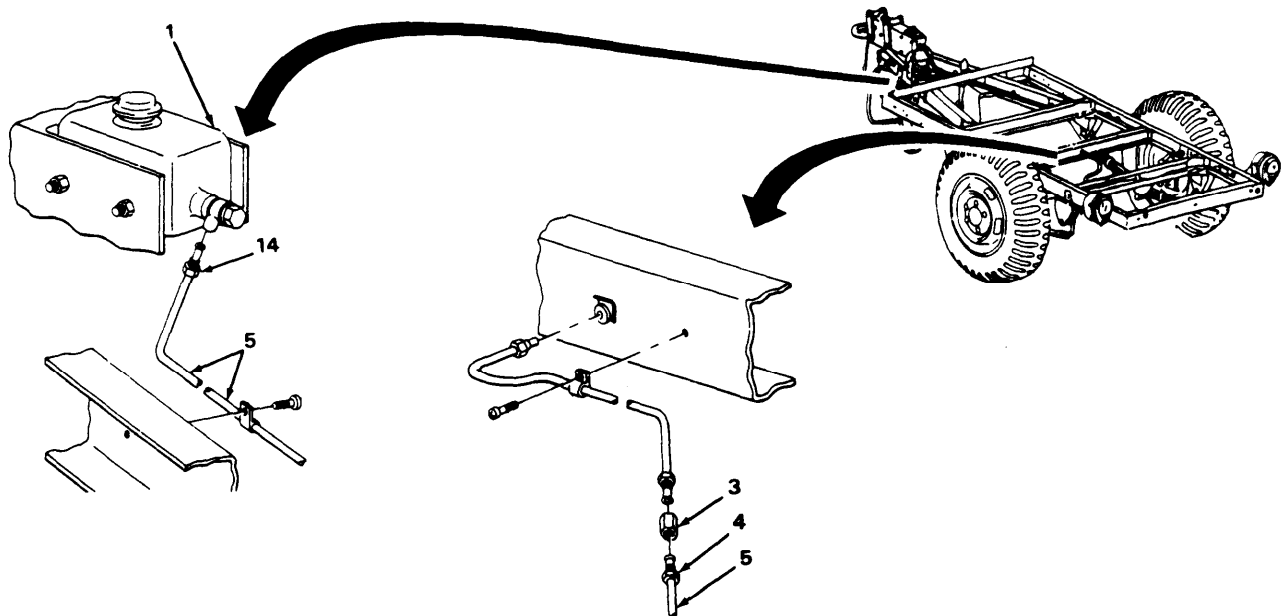

TA503934

4-34. HYDRAULIC BRAKE LINES, HOSES, AND FITTINGS REPLACEMENT (M416A1) (Con't).

3. Remove 3 screws (12) and clamps (13) securing tube assembly (5) to chassis (11). Remove tube assembly.
4. Remove 3 clamps (13) from tube assembly (5).

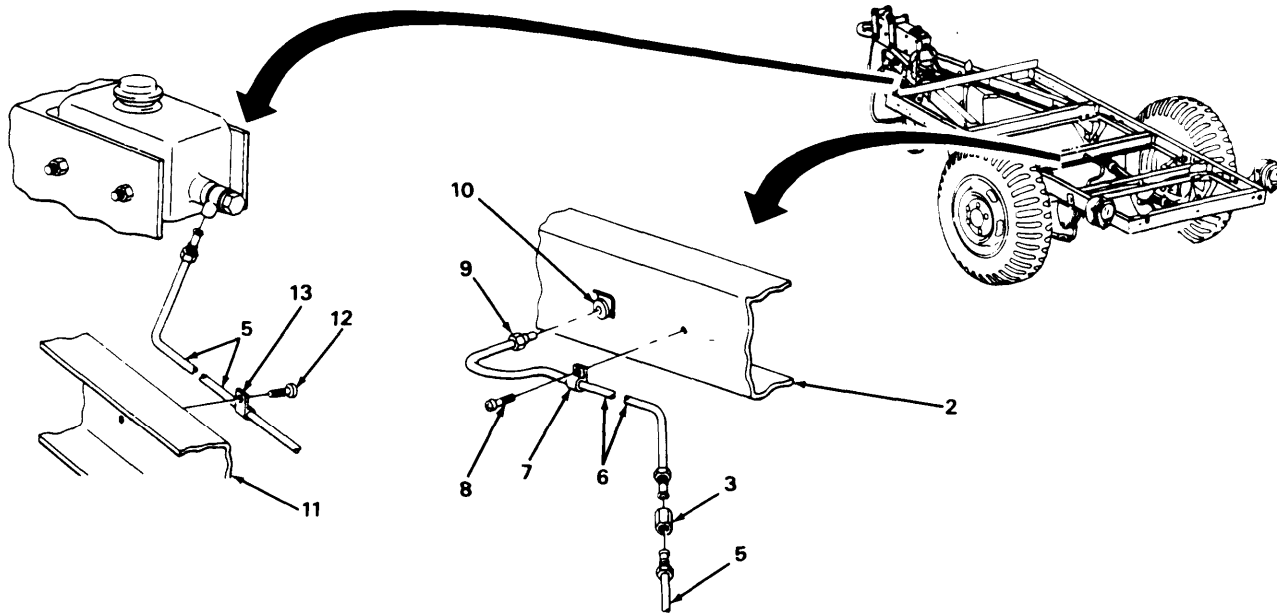

b. TUBE ASSEMBLY REMOVAL, COUPLING TO HOSE ASSEMBLY

NOTE

A suitable container should be used to catch any draining brake fluid. Ensure that all spills are cleaned up.

1. Remove coupling (3) from tube assembly (6).
2. Loosen inverted nut (9) and disconnect tube assembly (6) from hose assembly (10).
3. Remove screw (8) and clamp (7) securing tube assembly (6) to crossmember (2). Remove tube assembly.
4. Remove clamp (7) from tube assembly (6).

4-34. HYDRAULIC BRAKE LINES, HOSES, AND FITTINGS REPLACEMENT (M416A1) (Con't).

HOSE ASSEMBLY REMOVAL**NOTE**

A suitable container should be used to catch any draining brake fluid. Ensure that all spills are cleaned up.

1. Remove clip (15) securing hose assembly (10) to bracket (16). Remove hose assembly from bracket.
2. Remove hose assembly (10) and gasket (17) from tee (18). Discard gasket.

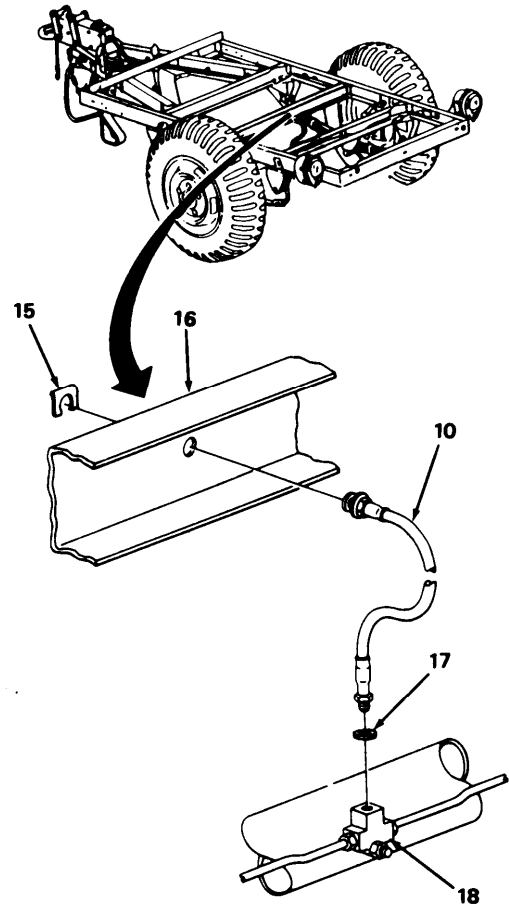

4-34. HYDRAULIC BRAKE LINES, HOSES, AND FITTINGS REPLACEMENT (M416A1) (Con't).

d. AXLE TUBE ASSEMBLY REMOVAL

NOTE

A suitable container should be used to catch any draining brake fluid. Ensure that all spills are cleaned up.

1. Loosen 2 inverted nuts (22) and disconnect 2 tube assemblies (23) from tee (18).
2. Loosen 2 inverted nuts (20) and disconnect 2 tube assemblies (23) from wheel cylinders (19).
3. Remove 2 screws (27) and clamps (28) securing 2 tube assemblies (23) to axle (21). Remove tube assemblies.
4. Remove 2 clamps (28) from tube assemblies (23),
5. Remove nut (24), lockwasher (25), flatwasher (26), and tee (18) from axle (21). Discard lockwasher.

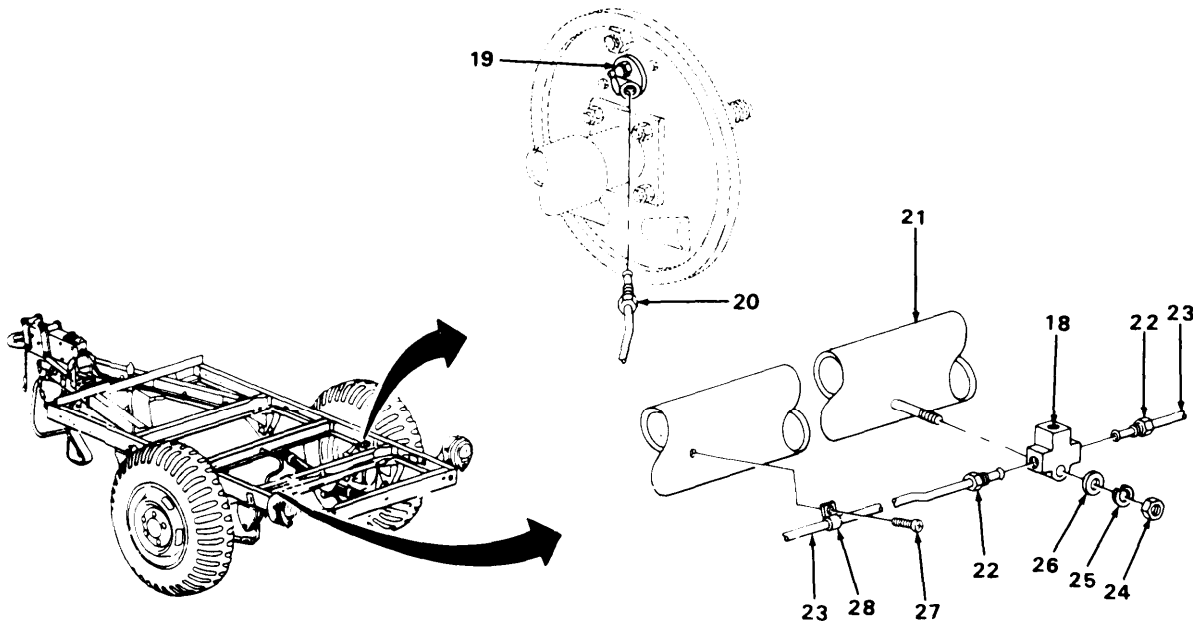

e. AXLE TUBE ASSEMBLY INSTALLATION

NOTE

For information on manufacturing tube assemblies (23), refer to Appendix G.

1. Install tee (18) on axle (21) with flatwasher (26), new lockwasher (25), and nut (24),
2. Install 2 clamps (28) on 2 tube assemblies (23).

TA503937

4-34. HYDRAULIC BRAKE LINES, HOSES, AND FITTINGS REPLACEMENT (M416A1) (Con't).

3. Install 2 clamps (28) and tube assemblies (23) on axle (21) with 2 screws (27).
4. Connect 2 tube assemblies (23) to wheel cylinders (19) and tighten 2 inverted nuts (20).
5. Connect 2 tube assemblies (23) to tee (18) and tighten 2 inverted nuts (22).

f. HOSE ASSEMBLY INSTALLATION

1. Install new gasket (17) on hose assembly (10).
2. Connect hose assembly (10) to tee (18).
3. Install hose assembly (10) on bracket (16) with clip (15).

4-34. HYDRAULIC BRAKE LINES, HOSES, AND FITTINGS REPLACEMENT (M416A1) (Con't).

g. TUBE ASSEMBLY INSTALLATION, COUPLING TO HOSE ASSEMBLY

NOTE

For information on manufacturing tube assembly (6), refer to Appendix G.

1. Install clamp (7) on tube assembly (6).
2. Install clamp (7) and tube assembly (6) on crossmember (2) with screw (8).
3. Connect tube assembly (6) to hose assembly (10) and tighten inverted nut (9).
4. Install coupling (3) on tube assembly (6).

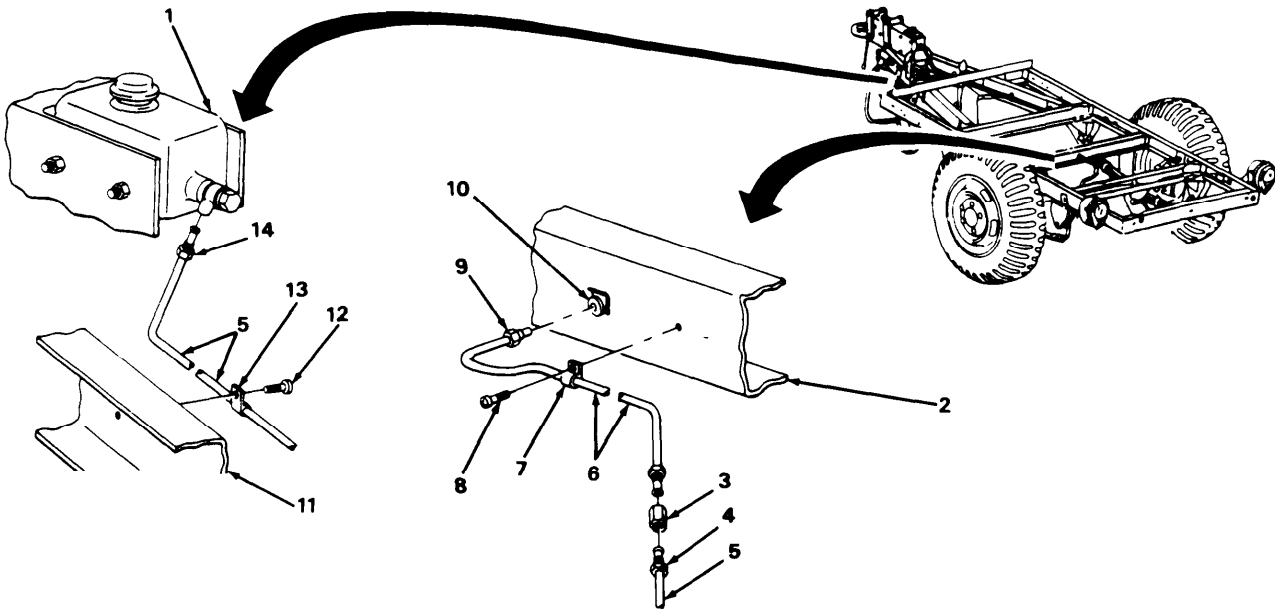

h. TUBE ASSEMBLY INSTALLATION, MASTER CYLINDER TO COUPLING

NOTE

For information on manufacturing tube assembly (5), refer to Appendix G.

1. Install 3 clamps (13) on tube assembly (5).
2. Install 3 clamps (13) and tube assembly (5) on chassis (11) with 3 screws (12).
3. Connect tube assembly (5) to coupling (3) and tighten inverted nut (4).
4. Connect tube assembly (5) to master cylinder (1) and tighten inverted nut (14).

FOLLOW-ON TASKS:

- Bleed brakes (para 4-33).

4-35. MASTER CYLINDER REPLACEMENT (M416A1).

This Task Covers:

- | | |
|------------|-----------------|
| a. Removal | b. Installation |
|------------|-----------------|

Initial Setup:

Materials/Parts:

- Rags (Item 9, Appendix E)
- Two locknuts

Tools/Test Equipment:

- General mechanic's tool kit
- Drain pan

a. REMOVAL

NOTE

A suitable container should be used to catch any draining brake fluid. Ensure that all spills are cleaned up,

1. Loosen inverted nut (6) and disconnect tube assembly (7) from master cylinder (5).
2. Remove 2 locknuts (1) and screws (2) securing master cylinder (5) to channel assembly (3). Remove 4 spacers (4) and master cylinder from channel assembly. Discard locknuts.

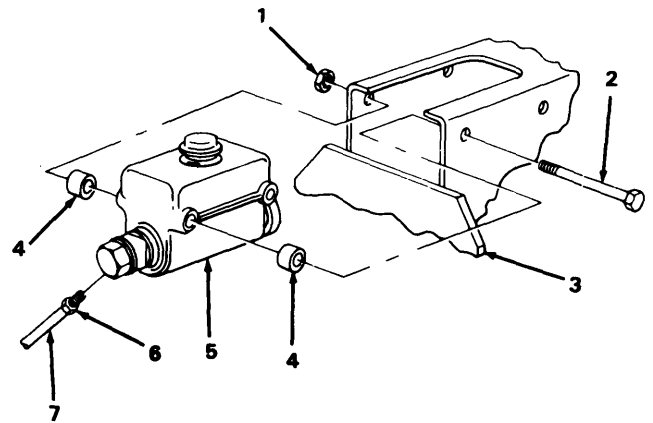
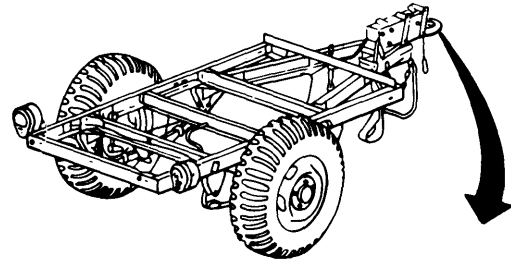

b. INSTALLATION

1. Install master cylinder (5) and 4 spacers (4) in channel assembly (3) with 2 screws (2) and new locknuts (1).
2. Connect tube assembly (7) to master cylinder (5) and tighten inverted nut (6).

FOLLOW-ON TASKS:

- Bleed brakes (para 4-33).

TA503940

Section IX. WHEELS, HUBS, AND BRAKEDRUMS MAINTENANCE

Paragraph Title	Page Number
Hub, Wheel Bearing, and Brakedrum Maintenance (M416)	4-58
Hub, Wheel Bearing, and Brakedrum Maintenance (M416A1)	4-62
Tires and Tubes Maintenance	4-65

4-36. HUB, WHEEL BEARING, AND BRAKEDRUM MAINTENANCE (M416).

This Task Covers:

- | | |
|--|---|
| <ul style="list-style-type: none"> a. Removal b. Disassembly c. Cleaning and Inspection | <ul style="list-style-type: none"> d. Assembly e. Installation f. Wheel Bearing Adjustment |
|--|---|

Initial Setup:

Equipment Conditions:

- Wheel removed (para 3-7),

Tools/Test Equipment:

- General mechanic's tool kit
- Floor jack
- Jackstand
- Spindle-nut socket wrench

Materials/Parts:

- Sealing compound (Item 3, Appendix E)
- Grease (Item 5, Appendix E)
- Dry cleaning solvent (Item 10, Appendix E)
- One oil seal

References:

- TM 9-214

a. REMOVAL

WARNING

DO NOT handle brakeshoes, brakedrums, or other brake components unless area has been properly cleaned. There may be asbestos dust on these components which can be dangerous if you touch it or breathe it. Wear an approved filter mask and gloves. Never use compressed air or a dry brush to clean brake components. Dust may be removed using an industrial-type vacuum cleaner. Clean dust or mud away from brake components with water and a wet, soft brush or cloth. Failure to follow this warning may result in serious illness or death to personnel.

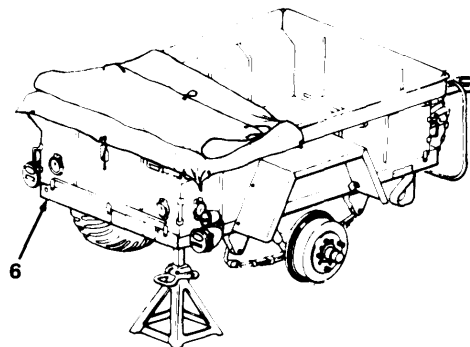

1. Position a suitable jackstand at rear corner of chassis (6). Lower and remove floor jack.

TA503941

4-36. HUB, WHEEL BEARING, AND BRAKEDRUM MAINTENANCE (M416) (Con't).

2. Remove dust cap (14) from hub (7).
3. Remove nut (13) and keywasher (12).
4. Remove nut (11) and keywasher (10).
5. Remove outer bearing (9) from hub (7).
6. Remove hub (7) and brakedrum (2) assembly from spindle (15).

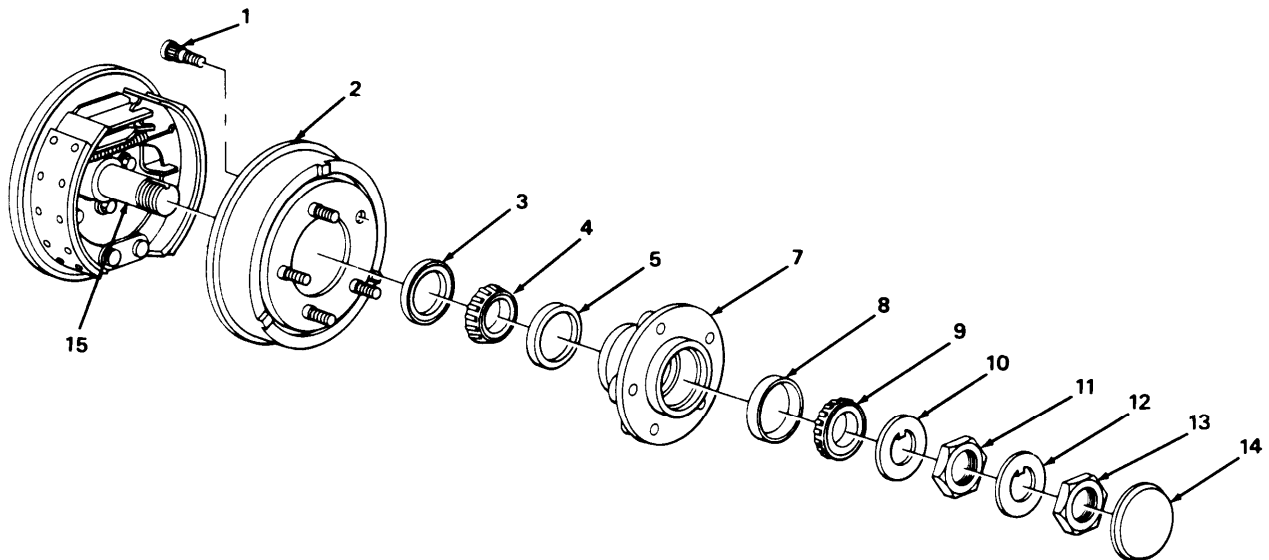
b. DISASSEMBLY

1. Remove oil seal (3) from hub (7) and discard.
2. Remove inner bearing (4) from hub (7).

NOTE

Hub (7) and brakedrum (2) assembly with inner and outer bearing cups (5 and 8) should remain assembled if brakedrum is to be repaired at direct support maintenance. If complete disassembly is required, continue with step 3.

3. Remove inner and outer bearing cups (5 and 8).
4. Tap out 5 shoulder bolts (1). Separate hub (7) from brakedrum (2).

4-36. HUB, WHEEL BEARING, AND BRAKEDRUM MAINTENANCE (M416) (Con't).

c. CLEANING AND INSPECTION

WARNING

- **DO NOT** handle brakeshoes, brakedrums, or other brake components unless area has been properly cleaned. There may be asbestos dust on these components which can be dangerous if you touch it or breathe it. Wear an approved filter mask and gloves. Never use compressed air or a dry brush to clean brake components. Dust may be removed using an industrial-type vacuum cleaner. Clean dust or mud away from brake components with water and a wet, soft brush or cloth. Failure to follow this warning may result in serious illness or death to personnel.
- Dry cleaning solvent P-D-680 is toxic and flammable. Always wear protective goggles and gloves, and use only in a well-ventilated area. Avoid contact with skin, eyes, and clothes, and **DO NOT** breathe vapors. **DO NOT** use near open flame or excessive heat. The solvent's flash point is 100°F-130°F (38°C-59°C). If you become dizzy while using cleaning solvent, immediately get fresh air and medical help. If solvent contacts eyes, immediately wash your eyes and get medical aid.

NOTE

If inner and outer bearings need replacing, inner and outer bearing cups must also be replaced.

1. Clean all removed parts with dry cleaning solvent and dry thoroughly.
2. Clean and inspect bearings and bearing cups in accordance with TM 9-214.
3. Replace any damaged part.

d. ASSEMBLY

1. Install hub (7) on brakedrum (2) with 5 shoulder bolts (1).
2. Install inner and outer bearing cups (5 and 8) squarely into hub (7) until fully seated.
3. Pack inner bearing (4) with grease and install in hub (7).
4. Install new oil seal (3) in hub (7).

e. INSTALLATION

1. Install hub (7) and brakedrum (2) assembly on spindle (15).
2. Pack outer bearing (9) with grease and install in hub (7).
3. Install keywasher (10) and nut (11) on spindle (15). Do not tighten nut.

f. WHEEL BEARING ADJUSTMENT

NOTE

Inner and outer bearings (4 and 9) are adjusted properly when there is almost no noticeable movement between brakedrum (2) and top edge of brake backing plate when hub rocks on spindle (15) and turns freely.

1. Tighten nut (11) until a slight drag is felt when hub (7) and brakedrum (2) are rotated.

4-36. HUB, WHEEL BEARING, AND BRAKEDRUM MAINTENANCE (M416) (Con't).

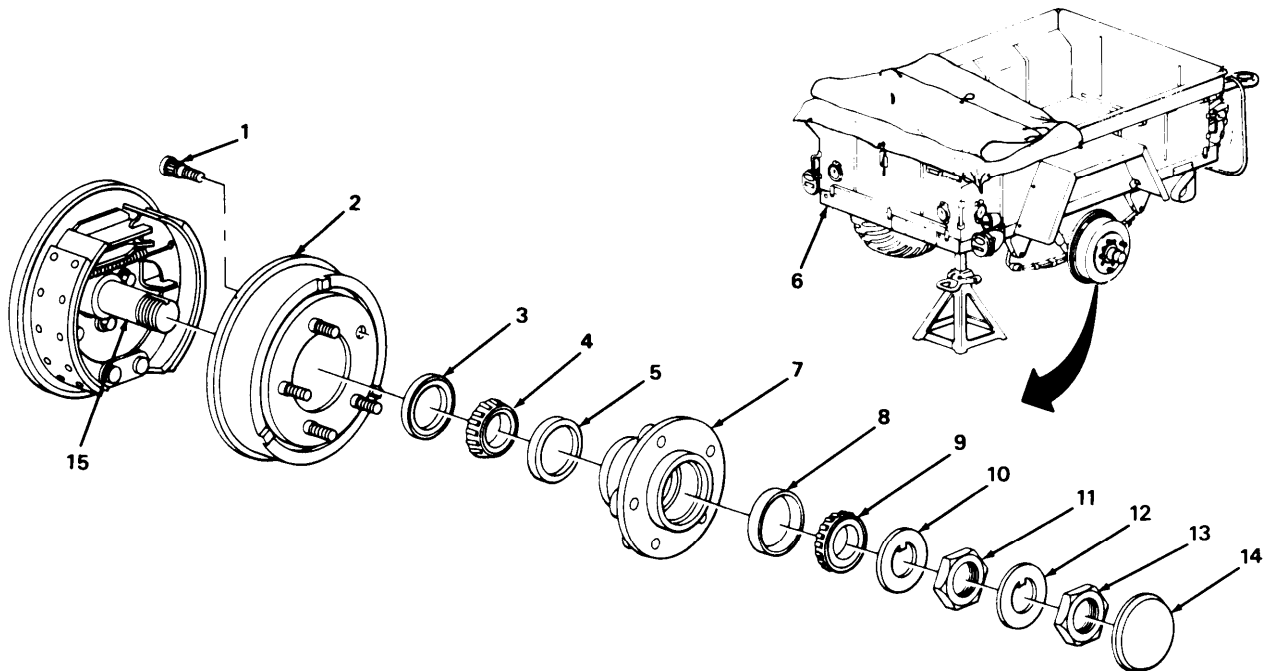

2. Rotate hub (7) and brakedrum (2) 1 full turn.
3. While rocking hub (7) and brakedrum (2) back and forth, loosen nut (11) until a slight looseness is felt.
4. While rocking hub (7) and brakedrum (2), slowly tighten nut (11) until looseness disappears.
5. Install keywasher (12) and nut (13) on spindle (15). Fully tighten nut.
6. Lightly coat flange of dust cap (14) with sealing compound. Install dust cap on hub (7).
7. Raise chassis (6) using a suitable floor jack positioned under axle near wheel. Remove jackstand from chassis.

FOLLOW-ON TASKS:

- Install wheel (para 3-7).
- Adjust brakes (para 4-28).

4-37. HUB, WHEEL BEARING, AND BRAKEDRUM MAINTENANCE (M416A1).

This Task Covers:

- | | |
|----------------------------|-----------------------------|
| a. Removal | d. Assembly |
| b. Disassembly | e. Installation |
| c. Cleaning and Inspection | f. Wheel Bearing Adjustment |
-

Initial Setup:

Equipment Conditions:

- Wheel removed (para 3-7) .

Tools/Test Equipment:

- General mechanic's tool kit
- Floor jack
- Jackstand

References:

- TM 9-214

Materials/Parts:

- Sealing compound (Item 3, Appendix E)
 - Grease (Item 5, Appendix E)
 - Dry cleaning solvent (Item 10, Appendix E)
 - One cotter pin
 - One oil seal
-

WARNING

DO NOT handle brakeshoes, brakedrums, or other brake components unless area has been properly cleaned. There may be asbestos dust on these components which can be dangerous if you touch it or breathe it. Wear an approved filter mask and gloves. Never use compressed air or a dry brush to clean brake components. Dust may be removed using an industrial-type vacuum cleaner. Clean dust or mud away from brake components with water and a wet, soft brush or cloth. Failure to follow this warning may result in serious illness or death to personnel.

1. Position a suitable jackstand under rear corner of chassis (4). Lower and remove floor jack,
2. Remove dust cap (10) from brakedrum (11).
3. Remove cotter pin (9) from slotted nut (8) and spindle (13). Discard cotter pin,
4. Remove slotted nut (8) from spindle (1 3).
5. Remove keywasher (7) and outer bearing (6) from brakedrum (11),
6. Remove brakedrum (11) from spindle (13).

b. DISASSEMBLY

1. Remove oil seal (1) from brakedrum (11) and discard.
2. Remove inner bearing (2) from brakedrum (11).

4-37. HUB, WHEEL BEARING, AND BRAKEDRUM MAINTENANCE (M416A1) (Con't).

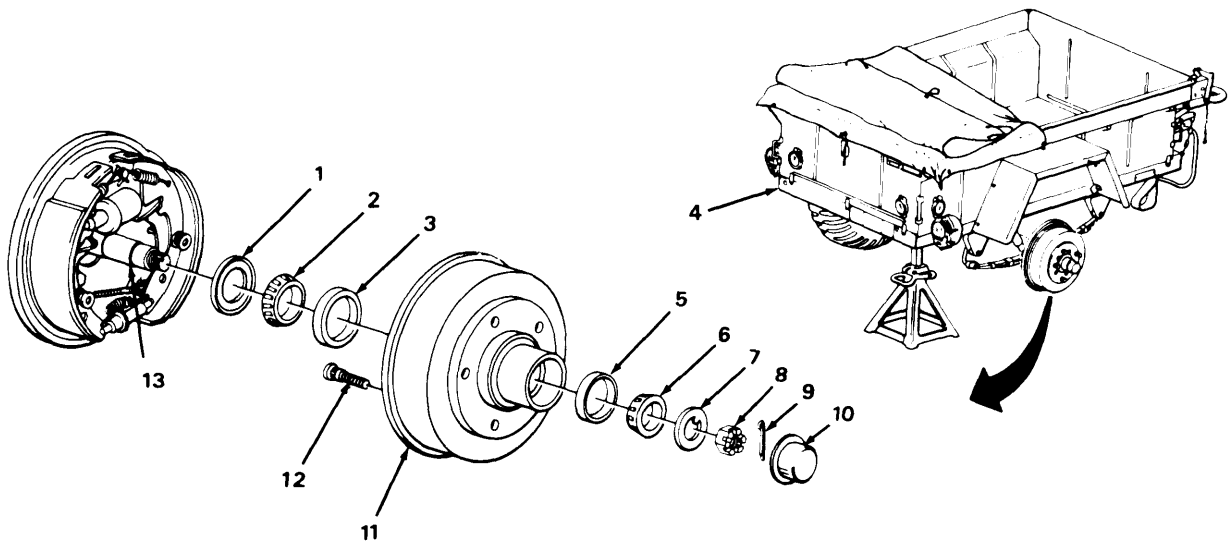
**NOTE**

Brakedrum (11) with inner and outer bearing cups (3 and 5) should remain assembled if brakedrum is to be repaired at direct support maintenance. If complete disassembly is required, continue with step 3.

3. Remove inner and outer bearing cups (3 and 5).
4. Tap out 5 shoulder bolts (12) from brakedrums (11).

c. CLEANING AND INSPECTION

WARNING

- **DO NOT** handle brakeshoes, brakedrums, or other brake components unless area has been properly cleaned. There may be asbestos dust on these components which can be dangerous if you touch it or breathe it. Wear an approved filter mask and gloves. Never use compressed air or a dry brush to clean brake components. Dust may be removed using an industrial-type vacuum cleaner. Clean dust or mud away from brake components with water and a wet, soft brush or cloth. Failure to follow this warning may result in serious illness or death to personnel.
- Dry cleaning solvent P-D-680 is toxic and flammable. Always wear protective goggles and gloves, and use only in a well-ventilated area. Avoid contact with skin, eyes, and clothes, and **DO NOT** breathe vapors. **DO NOT** use near open flame or excessive heat. The solvent's flash point is 100 °F-1300F (38 °C-590C). If you become dizzy while using cleaning solvent, immediately get fresh air and medical help. If solvent contacts eyes, immediately wash your eyes and get medical aid.

NOTE

If inner and outer bearings need replacing, inner and outer bearing cups must also be replaced.

1. Clean all removed parts with dry cleaning solvent and dry thoroughly.

TA503944

4-37. HUB, WHEEL BEARING, AND BRAKEDRUM MAINTENANCE (M416A1) (Con't).

2. Clean and inspect bearings and bearing cups in accordance with TM 9-214.
3. Replace any damaged part.

d. ASSEMBLY

1. Tap 5 shoulder bolts (12) into brakedrum (11),
2. Install inner and outer bearing cups (3 and 5) squarely into brakedrum (11).
3. Pack inner bearing (2) with grease and install in brakedrum (11).
4. Install new oil seal (1).

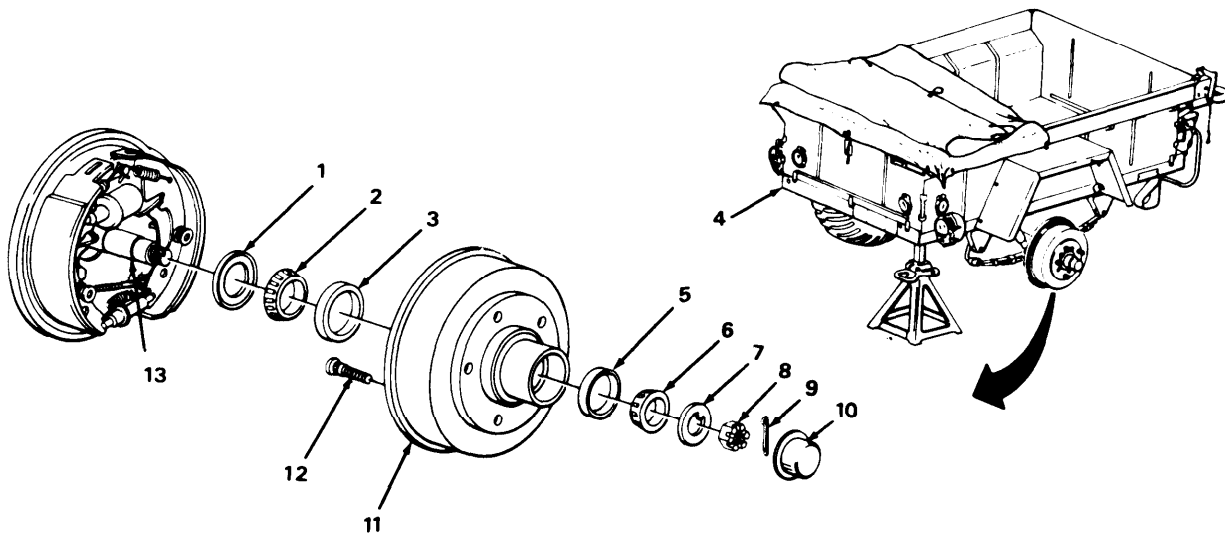

e. INSTALLATION

1. Install brakedrum (11) on spindle (13).
2. Pack outer bearing (6) with grease and install in brakedrum (11).
3. Install keywasher (7) and slotted nut (8) on spindle (13). Do not tighten slotted nut.

f. WHEEL BEARING ADJUSTMENT

NOTE

Inner and outer bearings (2 and 6) are adjusted properly when there is almost no noticeable movement between brakedrum (11) and top edge of brake backing plate when brakedrum rocks on spindle (13) and turns freely.

1. While rotating brakedrum (11), tighten slotted nut (8) until a slight drag is felt.
2. Rotate brakedrum (11) 1 full turn.

TA503945

4-37. HUB, WHEEL BEARING, AND BRAKEDRUM MAINTENANCE (M416A1) (Con't).

3. While rocking brakedrum (11) back and forth, loosen slotted nut (8) until a slight looseness is felt.
4. While rocking brakedrum (11), slowly tighten slotted nut (8) until looseness disappears.
5. Install new cotter pin (9) in slotted nut (8) and spindle (13).
6. Lightly coat flange of dust cap (10) with sealing compound. Install dust cap on brakedrum (11).
7. Raise chassis (4) using a suitable floor jack positioned under axle near wheel. Remove jackstand from chassis.

FOLLOW-ON TASKS:

- Install wheel (para 3-7).
- Adjust brakes (para 4-29).

4-38. TIRES AND TUBES MAINTENANCE.

Replace tires and tubes and repair tubes in accordance with TM 9-2610-200-24.

Section X. FRAME AND TOWING ATTACHMENTS MAINTENANCE

Paragraph Title	Page Number
Actuator With Drawbar Coupler Maintenance (M416A1)	4-68
Channel Replacement	4-66
Drawbar Coupler Maintenance (M416)	4-74
Landing Leg Replacement	4-77

4-39. CHANNEL REPLACEMENT.

This Task Covers:

- | | |
|------------|-----------------|
| a. Removal | b. Installation |
|------------|-----------------|

Initial Setup:

Equipment Conditions:

- Actuator with drawbar coupler removed (M416A1) (para 4-40).
- Drawbar coupler disassembled (M416) (para 4-41).
- Intervehicular cable removed (para 4-20).
- Tube assembly removed (master cylinder to coupler) (M416A1) (para 4-34).

Materials/Parts:

- Two locknuts
- Two lockwashers

Personnel Required: Two

Tools/Test Equipment:

- General mechanic's tool kit
- Common No. 1 shop set
- Torque wrench, 0-175 lb.-ft. (0-237 N.m)

a. REMOVAL

1. Remove 2 nuts (7), lockwashers (6) ,and screws (3) securing channel (8) to chassis bracket (4), Discard lockwashers.

NOTE

On right side only, handbrake lever and mounting bracket are removed when U-bolt (9) is removed.

2. Remove 2 locknuts (2) from U-bolt (9) securing channel (8) to front crossmember (1). Remove U-bolt and channel from chassis (5). Discard locknuts.

b. INSTALLATION

1. Position channel (8) for installation.

4-39. CHANNEL REPLACEMENT (Con't).

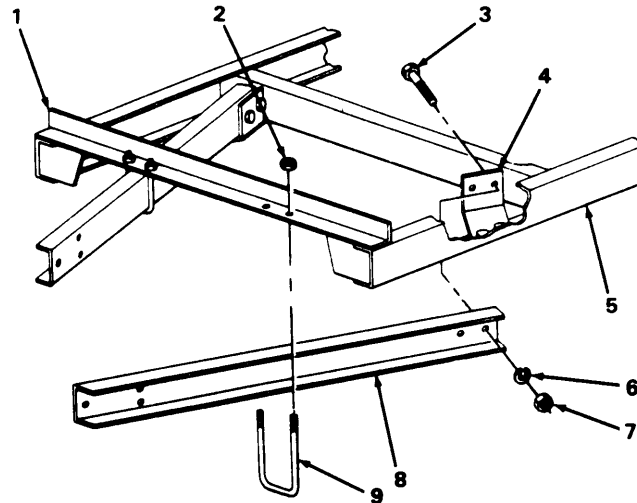
**NOTE**

On right side only, handbrake lever and mounting bracket are installed when U-bolt (9) is installed.

2. Loosely install channel (8) to front crossmember (1) with U-bolt (9) and 2 new locknuts (2).
3. Loosely install channel (8) to chassis bracket (4) with 2 screws (3), new lockwashers (6), and nuts (7).
4. Tighten 2 locknuts (2) to 40 lb.-ft. (54 N•m). Tighten 2 nuts (7) to 75 lb.-ft. (102 N•m).

FOLLOW-ON TASKS:

- Install tube assembly (master cylinder to coupling) (M416A1) (para 4-34).
- Install intervehicular cable (para 4-20).
- Assemble drawbar coupler (M416) (para 4-41).
- Install actuator with drawbar coupler (M416A1) (para 4-40).

4-40. ACTUATOR WITH DRAWBAR COUPLER MAINTENANCE (M416A1).

This Task Covers:

- | | |
|----------------------------|-----------------|
| a. Removal | d. Assembly |
| b. Disassembly | e. Installation |
| c. Cleaning and Inspection | |
-

Initial Setup:

Equipment Conditions:

- Landing leg removed (para 4-42).

Tools/Test Equipment:

- General mechanic's tool kit
- Common No. 1 shop set
- Retaining ring pliers

Materials/Parts:

- Dry cleaning solvent (Item 10, Appendix E)
- One snapping
- Seventeen locknuts

Personnel Required: Two

a. REMOVAL

1. Loosen inverted nut (2) and disconnect tube assembly (3) from master cylinder (1).

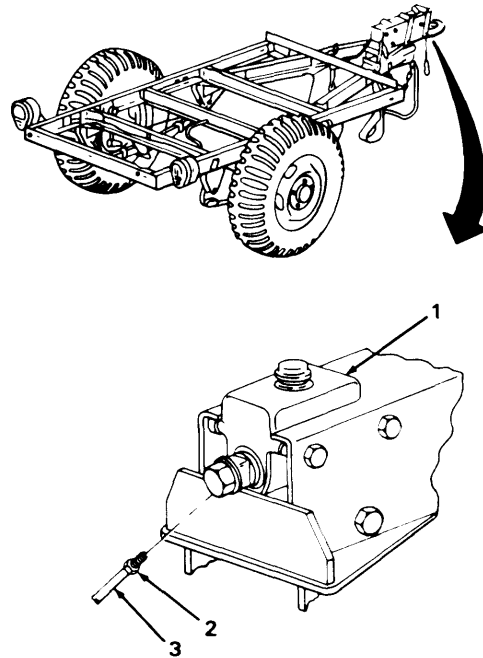

TA503947

4-40, ACTUATOR WITH DRAWBAR COUPLER MAINTENANCE (M416A1) (Con't).

2. Remove 4 screws (8) and locknuts (6) securing actuator (10) to channels (7). Discard locknuts.

NOTE

Ensure that assistant supports actuator (10) for steps 3 and 4.

3. Remove nut (4) and screw (9) securing 2 safety chains (5) to channels (7). Remove safety chains.
4. Remove actuator (10) from channels (7).

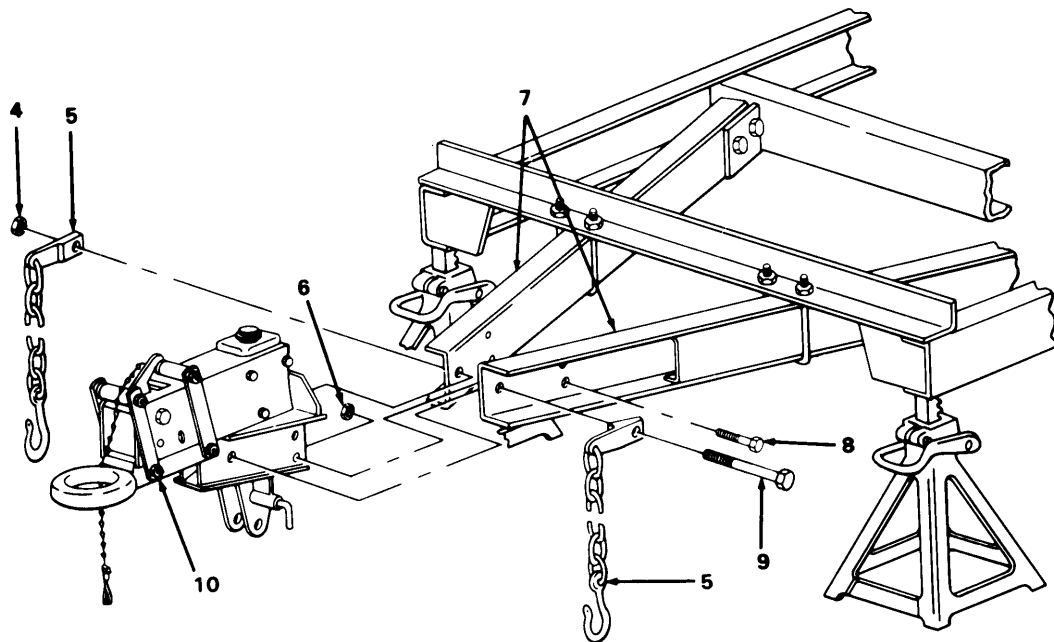

4-40. ACTUATOR WITH DRAWBAR COUPLER MAINTENANCE (M416A1) (Con't).

b. DISASSEMBLY

1. Remove plug (35) from lockpin (34) and channel (16).
2. Bend lockpin (34) until straight. Remove lockpin and spring (33) from channel (16).
3. Remove locknut (20) and screw (19) securing drawbar coupler bracket (21) to channel (16). Remove drawbar coupler bracket. Discard locknut,
4. Remove 2 locknuts (24) and screws (22) securing master cylinder (1) to channel (16). Remove master cylinder and 4 spacers (23). Discard locknuts,
5. Remove pin (30), washer (31), spring (32), and push rod (25) from channel (16).

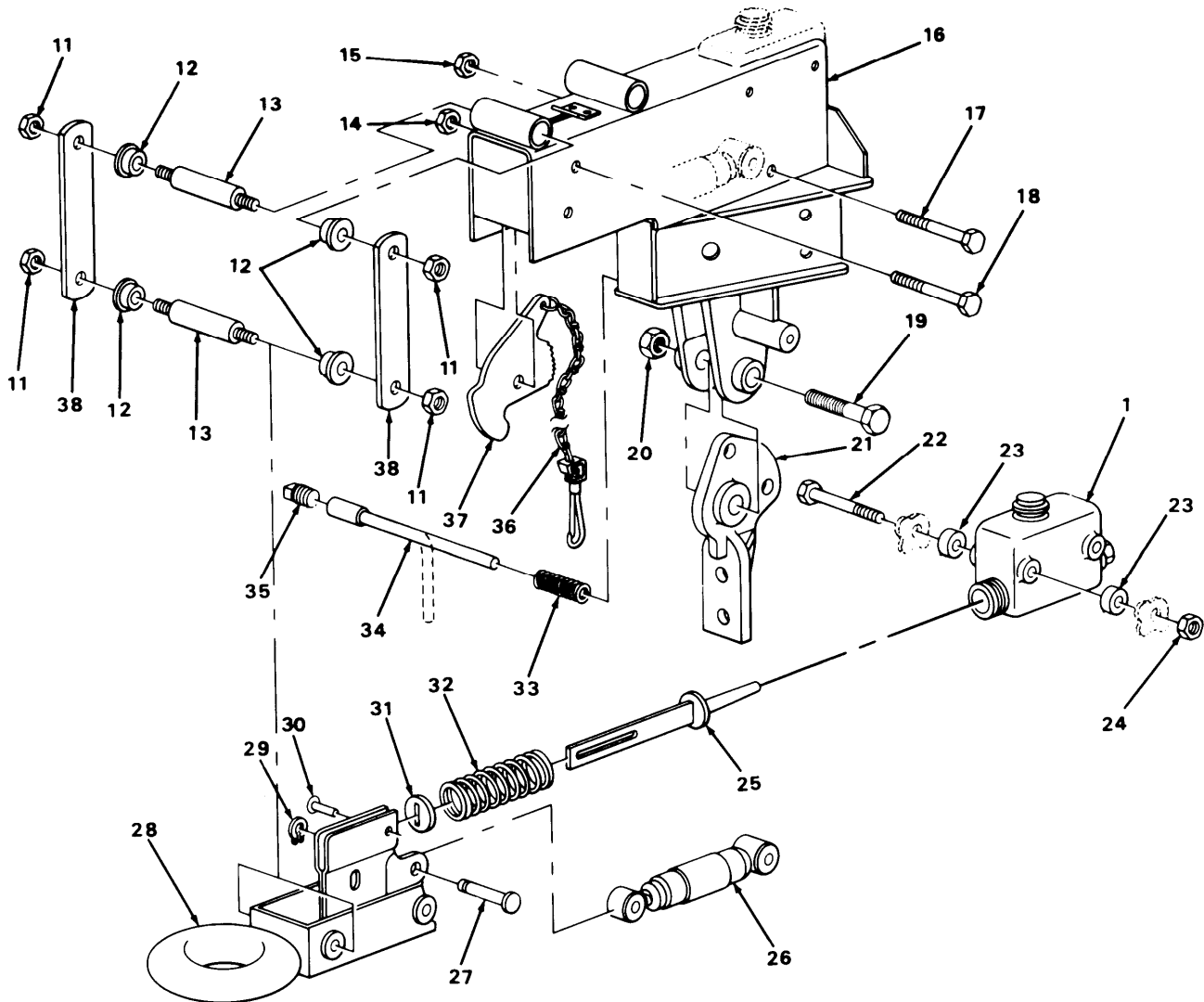

TA503949

4-40. ACTUATOR WITH DRAWBAR COUPLER MAINTENANCE (M416A1) (Con't).

6. Remove 8 locknuts (11), 4 connecting links (38), 8 bearings (12), and 4 shafts (13). Discard locknuts.
7. Remove locknut (15) and screw (17) securing shock absorber (26) to channel (1 6). Remove drawbar coupler (28) with shock absorber from channel. Discard locknut.
8. Remove snapping (29) and pin (27) and separate shock absorber (26) from drawbar coupler (28). Discard snapping.
9. Remove locknut (14) and screw (18) securing breakaway lever (37) to channel (1 6). Remove breakaway lever. Discard locknut.
10. If damaged, open link and remove breakaway chain (36) from breakaway lever (37).

c. CLEANING AND INSPECTION

WARNING

Dry cleaning solvent P-D-680 is toxic and flammable. Always wear protective goggles and gloves, and use only in a well-ventilated area. Avoid contact with skin, eyes, and clothes, and DO NOT breathe vapors. DO NOT use near open flame or excessive heat. The solvent's flash point is 100°F-130°F (38°C-59°C). If you become dizzy while using cleaning solvent, immediately get fresh air and medical help. If solvent contacts eyes, immediately wash your eyes and get medical aid.

1. Clean all removed parts with dry cleaning solvent and dry thoroughly.
2. Inspect all parts for cracks, distortion, damaged threads, excessive corrosion, or other damage.
3. Replace all damaged parts.

d. ASSEMBLY

1. If removed, install breakaway chain (36) on breakaway lever (37). Close link to secure breakaway chain.
2. Install breakaway lever (37) on channel (16) with screw (18) and new locknut (14).
3. Install shock absorber (26) on drawbar coupler (28) with pin (27) and new snapping (29).
4. Position drawbar coupler (28) with shock absorber (26) in channel (1 6). Secure shock absorber to channel with screw (17) and new locknut (15).
5. Secure drawbar coupler (28) to channel (16) with 4 shafts (13), 8 bearings (12), 4 connecting links (38), and 8 new locknuts (11).
6. Install washer (31), spring (32), push rod (25), and pin (30) on drawbar coupler (28).
7. Install master cylinder (1) on channel (16) with 4 spacers (23), 2 screws (22), and new locknuts (24).
8. Install drawbar coupler bracket (21) on channel (16) with screw (19) and new locknut (20).
9. Install lockpin (34) and spring (33) in channel (16). Bend lockpin to a 90° angle.
10. Install plug (35) in channel (16).

4-40. ACTUATOR WITH DRAWBAR COUPLER MAINTENANCE (M416A1) (Con't).

e. INSTALLATION

1. With assistance, position actuator (10) in channels (7).
2. Install 2 safety chains (5) with screw (9) and nut (4).
3. install 4 screws (8) and new locknuts (6) to secure actuator (10) to channels (7).

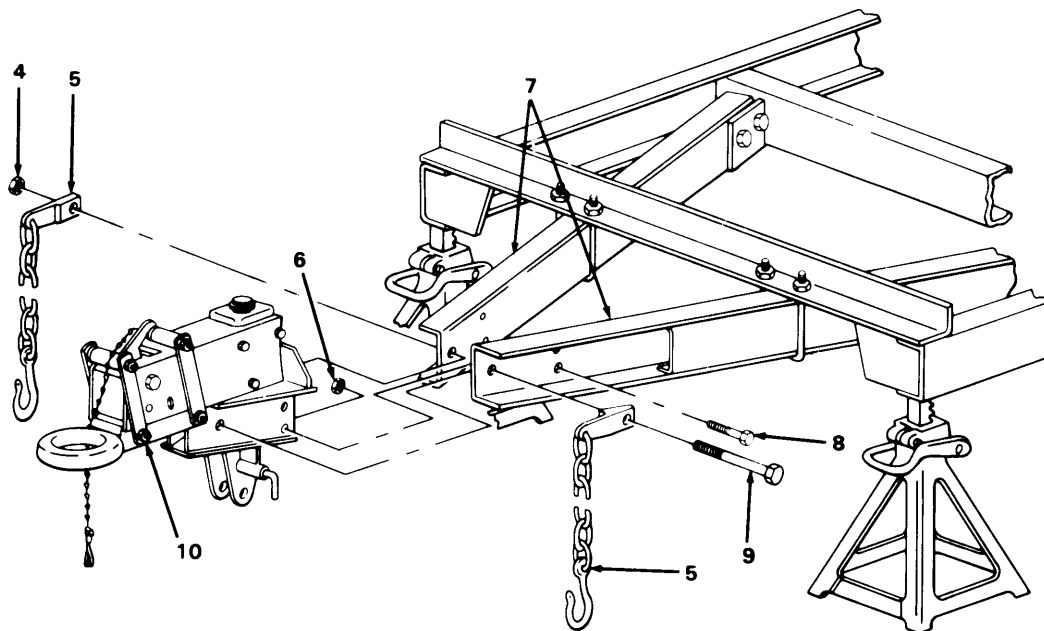

4-40. ACTUATOR WITH DRAWBAR COUPLER MAINTENANCE (M416A1) (Con't).

4. Connect tube assembly (3) to master cylinder (1) and tighten inverted nut (2).

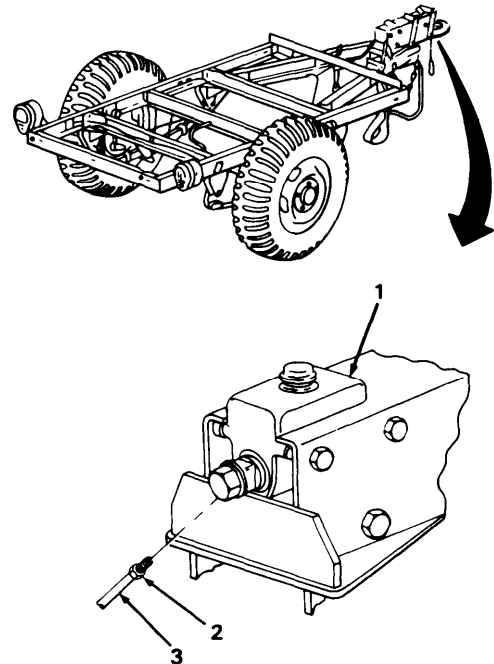
**FOLLOW-ON TASKS:**

- Install landing leg (para 4-42).
- Lubricate landing leg lockpin and pivot bolt (Chapter 3, Section 1).
- Bleed brakes (para 4-33).

4-41. DRAWBAR COUPLER MAINTENANCE (M416).

This Task Covers:

- | | |
|----------------------------|-------------|
| a. Disassembly | c. Assembly |
| b. Cleaning and Inspection | |
-

Initial Setup:

Equipment Conditions:

- Landing leg removed (para 4-42).

Tools/Test Equipment:

- General mechanic's tool kit
- Feeler gage

Materials/Parts:

- Dry cleaning solvent (Item 10, Appendix E)
 - One cotter pin
 - Six locknuts
-

a. DISASSEMBLY

1. Remove plug (10) from lockpin (11).
2. Bend lockpin (11) until straight. Remove lockpin and spring (1 2).
3. Remove locknut (20) and screw (13) securing drawbar coupler bracket (19) to drawbar bracket (2). Remove drawbar coupler bracket. Discard locknut.
4. Remove cotter pin (7) and slotted nut (8) securing drawbar coupler (1) to drawbar bracket (2). Remove keywasher (6), spring (5), flatwasher (4), and drawbar coupler from drawbar bracket. Discard cotter pin,
5. Remove 2 lubrication fittings (3) from drawbar bracket (2).
6. Remove locknut (18) and screw (16) securing 2 safety chains (17) to drawbar bracket (2) and channels (14). Remove safety chains. Discard locknut.
7. Remove 4 locknuts (9) and screws (15) securing drawbar bracket (2) to channels (14). Remove drawbar bracket. Discard locknuts.

b. CLEANING AND INSPECTION

WARNING

Dry cleaning solvent P-D-680 is toxic and flammable. Always wear protective goggles and gloves, and use only in a well-ventilated area. Avoid contact with skin, eyes, and clothes, and DO NOT breathe vapors. DO NOT use near open flame or excessive heat. The solvent's flash point is 100°F-130°F (38°C-59°C). If you become dizzy while using cleaning solvent, immediately get fresh air and medical help, if solvent contacts eyes, immediately wash your eyes and get medical aid.

1. Clean all removed parts with dry cleaning solvent and dry thoroughly.
2. Inspect all parts for cracks, distortion, damaged threads, excessive corrosion, or other damage.
3. Replace all damaged parts.

4-41. DRAWBAR COUPLER MAINTENANCE (M416) (Con't).

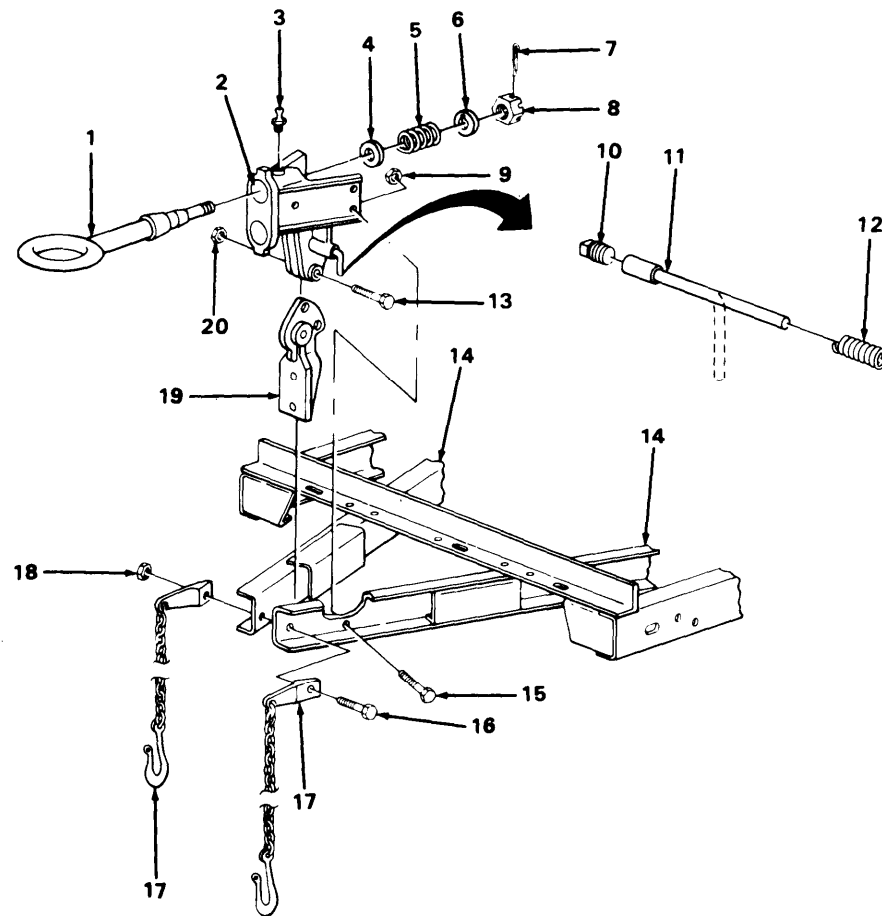
c. ASSEMBLY

1. Install drawbar bracket (2) on channels (14) with 4 screws (15) and new locknuts (9).
2. Install 2 safety chains (17) on drawbar bracket (2) and channels (14) with screw (16) and new locknut (18).
3. Install 2 lubrication fittings (3) in drawbar bracket (2).

NOTE

Drawbar coupler (1) may be positioned in either of 2 positions. Determine height needed before assembling.

4. install drawbar coupler (1) in high or low position in drawbar bracket (2).
5. Install flatwasher (4), spring (5), keywasher (6), and slotted nut (8) on drawbar coupler (1). Tighten slotted nut until a 0.010 in. (0.25 mm) feeler gage inserted between coils of spring can be removed with a slight drag.

TA503952

4-41. DRAWBAR COUPLER MAINTENANCE (M416) (Con't).

6. Secure slotted nut (8) to drawbar coupler (1) with new cotter pin (7).
7. Install drawbar coupler bracket (19) on drawbar bracket (2) with screw (13) and new locknut (20).
8. Install spring (12) and lockpin (11). Bend lockpin to a 90° angle. Install plug (10),

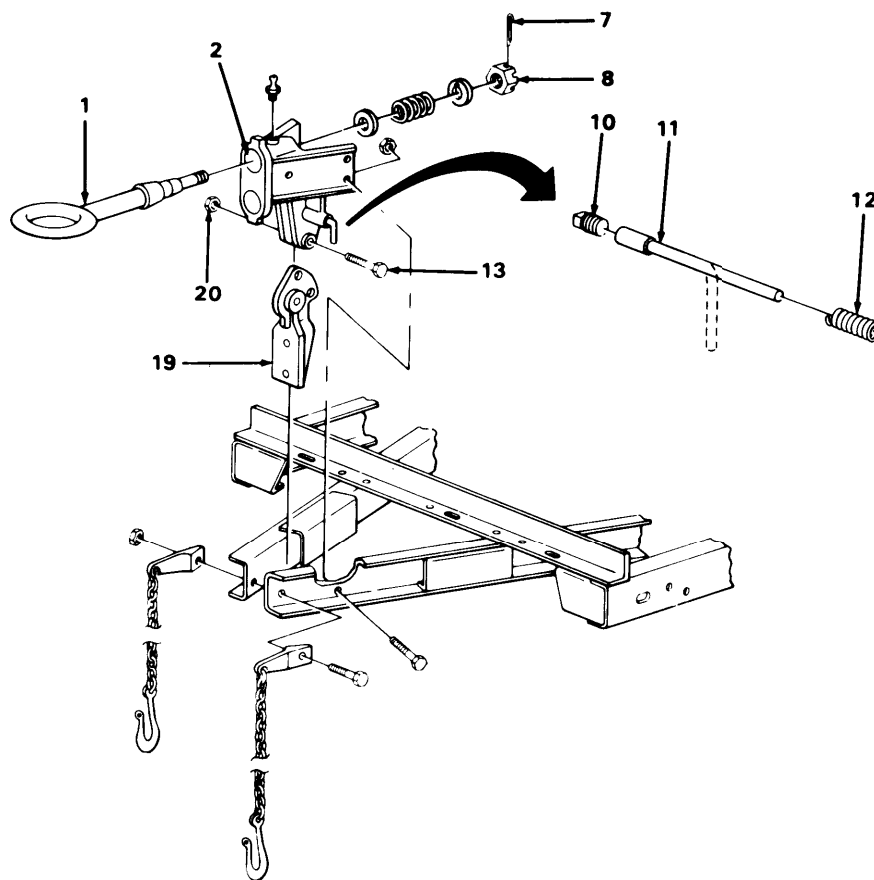

FOLLOW-ON TASKS:

- Install landing leg (para 4-42).
- Lubricate landing leg lockpin and pivot bolt, and drawbar bracket (Chapter 3, Section 1).

4-42. LANDING LEG REPLACEMENT.

This Task Covers:

- a. Removal b. Installation
-

Initial Setup:

Materials/Parts:

- Two locknuts

Tools/Test Equipment:

- General mechanic's tool kit
 - Floor jack
 - Two jackstands
-

a. REMOVAL

1. Raise front of trailer and position 2 jackstands under framerails (1) at front crossmember (2). Support front of trailer on jackstands.
2. Remove 2 locknuts (3) and screws (6) securing landing leg (5) to drawbar coupler bracket (4). Remove landing leg. Discard locknuts.

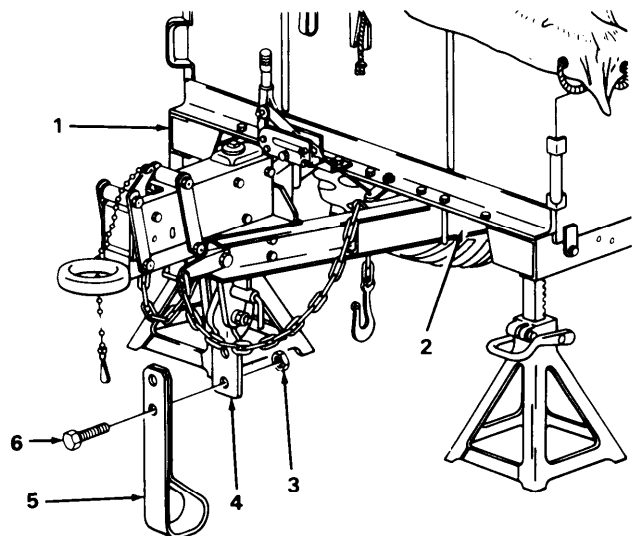

b. INSTALLATION

1. Install landing leg (5) on drawbar coupler bracket (4) with 2 screws (6) and new locknuts (3).

WARNING

Ensure that landing leg is locked in the down position before continuing with task. Failure to follow this warning could cause trailer to fall, resulting in injury to personnel or damage to equipment.

2. Ensure that landing leg (5) is locked in the down position (para 2-8).
3. Raise front of trailer and remove 2 jackstands from framerails (1) at front crossmember (2). Rest weight of trailer on landing leg (5).

TA503954

Section XI. SPRINGS AND SHOCK ABSORBERS MAINTENANCE

Paragraph Title	Page Number
Shock Absorber Replacement.....	4-84
Spring Assembly Maintenance.....	4-78
Spring Bumper Replacement.....	4-83

4-43. SPRING ASSEMBLY MAINTENANCE.

This Task Covers:

- | | |
|--|---|
| <ul style="list-style-type: none"> a. Spring Assembly Removal b. U-Bolt Removal c. Front and Rear Bracket Removal d. Cleaning and Inspection | <ul style="list-style-type: none"> e. Front and Rear Bracket Installation f. U-Bolt Installation g. Spring Assembly installation |
|--|---|

Initial Setup:

Materials/Parts:

- Detergent (Item 4, Appendix E)
- Dry cleaning solvent (Item 10, Appendix E)
- One cotter pin
- Two bushings
- Twelve lockwashers

Tools/Test Equipment:

- General mechanic's tool kit
- Floor jack
- Jackstand

a. SPRING ASSEMBLY REMOVAL

1. Position a suitable floorjack under axle (1) and raise trailer until tires clear ground.
2. Position jackstand under rear corner of chassis (2).
3. Lower floor jack until tires rest on ground. Remove floorjack. Jackstand holds weight of trailer off spring.

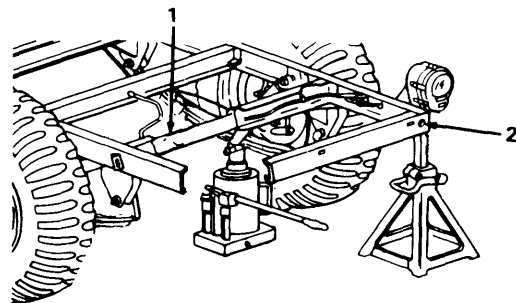

4-43. SPRING ASSEMBLY MAINTENANCE (Con't).

4. Remove 4 nuts (6), lockwashers (7), and 2 U-bolts (3) and move plate assembly (5) away from spring assembly (4). Discard lockwashers.
5. Position floor jack under center of spring assembly (4) to support weight of spring.

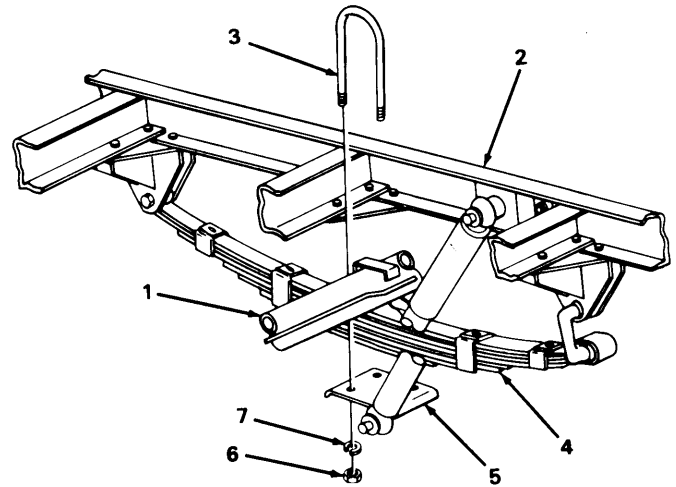

6. Remove cotter pin (16), nut (15), and bolt (8) securing spring assembly (4) to front bracket (14). Discard cotter pin.
7. Remove fitting (9) from bolt (8).
8. Remove bearing (12) securing spring assembly (4) to U-bolt (13).
9. Remove fitting (11) from bearing (12).
10. Lower floor jack and remove spring assembly (4) from U-bolt (13).

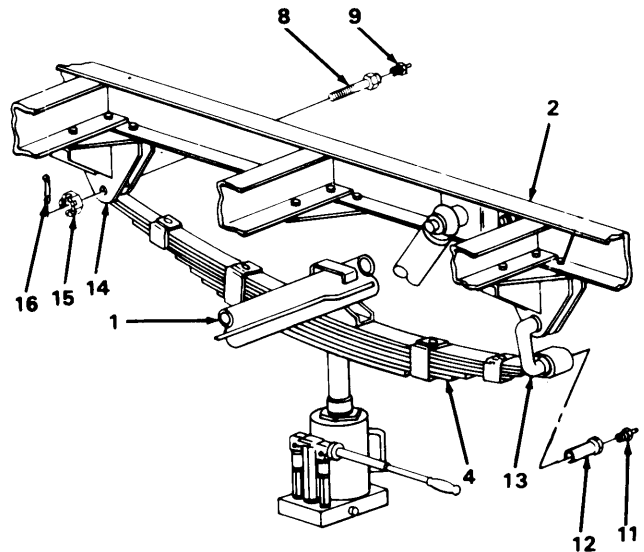

4-43. SPRING ASSEMBLY MAINTENANCE (Con't).

b. U-BOLT REMOVAL

1. Remove bearing (21) and U-bolt (13) from rear bracket (10).
2. Remove fitting (20) from bearing (21).
3. Remove 2 bushings (22) and retainers (23) from U-bolt (13). Discard bushings.

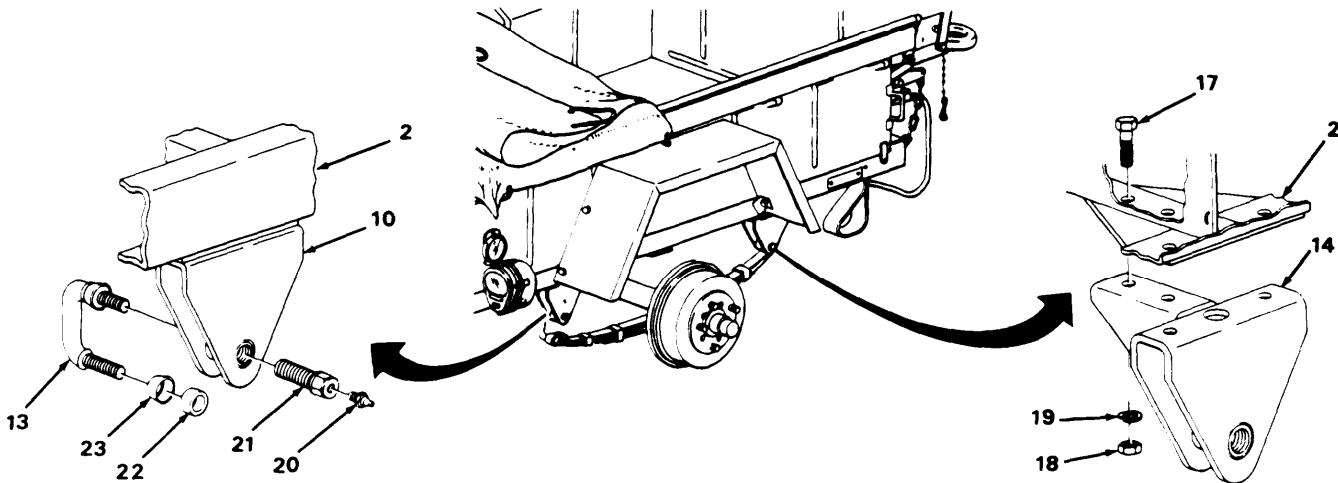

c. FRONT AND REAR BRACKET REMOVAL

1. Remove 4 nuts (18), lockwashers (19), screws (17), and front bracket (14) from chassis (2). Discard lockwashers.
2. Repeat step 1 to remove rear bracket (10) from chassis (2).

d. CLEANING AND INSPECTION

WARNING

Dry cleaning solvent P-D-680 is toxic and flammable. Always wear protective goggles and gloves, and use only in a well-ventilated area. Avoid contact with skin, eyes, and clothes, and DO NOT breathe vapors. DO NOT use near open flame or excessive heat. The solvent's flash point is 100°F-130°F (38°C-59°C). If you become dizzy while using cleaning solvent, immediately get fresh air and medical help. If solvent contacts eyes, immediately wash your eyes and get medical aid.

1. Clean all removed metal parts in dry cleaning solvent. Use soap and water solution to clean all other parts. Dry thoroughly.

TA503957

4-43. SPRING ASSEMBLY MAINTENANCE (Con't).

2. Inspect all parts for cracks, distortion, damaged threads, excessive corrosion, or other damage.
3. Replace all damaged parts.

e. FRONT AND REAR BRACKET INSTALLATION

1. Install front bracket (14) on chassis (2) with 4 screws (17), new lockwashers (19), and nuts (18).
2. Repeat step 1 to install rear bracket (10) on chassis (2).

f. U-BOLT INSTALLATION

1. Install 2 retainers (23) and new bushings (22) on U-bolt (13).
2. Install fitting (20) in bearing (21).
3. Install U-bolt (13) on rear bracket (10) with bearing (21).

g. SPRING ASSEMBLY INSTALLATION

1. Install fitting (11) in bearing (12).
2. Use a floor jack to raise spring assembly (4) into position on U-bolt (13).
3. Secure spring assembly (4) to U-bolt (13) with bearing (12).
4. Install fitting (9) in bolt (8).
5. Secure spring assembly (4) to front bracket (14) with bolt (8), nut (15), and new cotter pin (16).
6. Lower floor jack and remove.

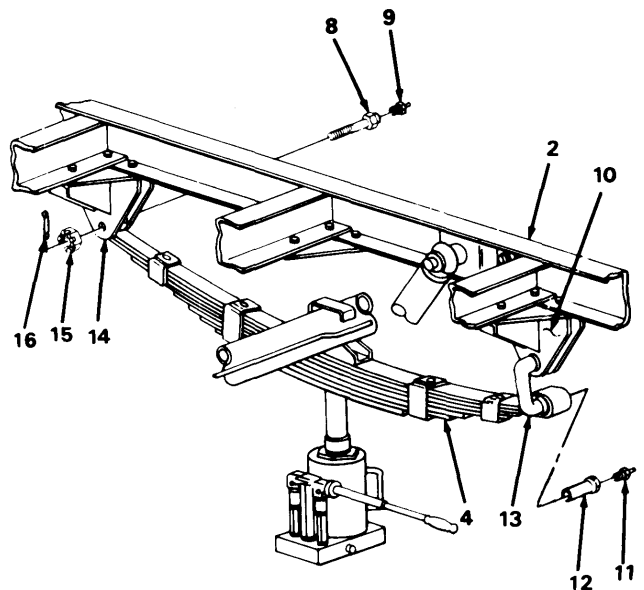

4-43. SPRING ASSEMBLY MAINTENANCE (Con't).

7. Position plate assembly (5) under spring assembly (4) and axle (1).
8. Secure spring assembly (4) to axle (1) with 2 U-bolts (3), 4 new lockwashers (7), and nuts (6).
9. Use a floor jack to raise axle (1) so that tires are off ground.
10. Remove jackstand.
11. Lower floor jack and remove.

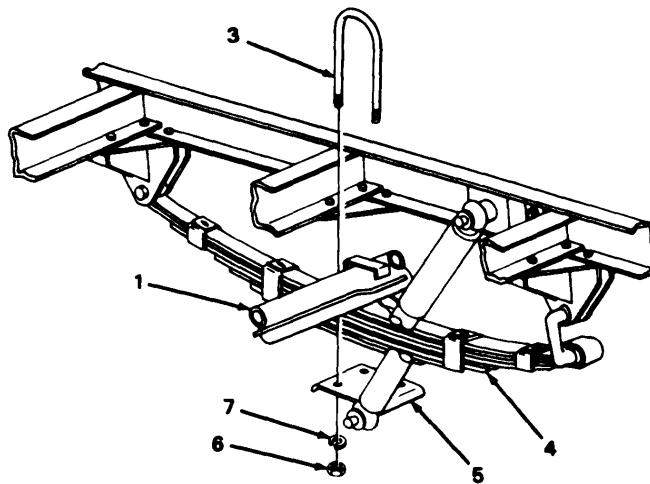

FOLLOW-ON TASKS:

- Lubricate spring assembly (Chapter 3, Section I).

4-44. SPRING BUMPER REPLACEMENT.

This Task Covers:

a. Removal

b. Installation

Initial Setup:

Materials/Parts:

- Two lockwashers

Tools/Test Equipment:

- General mechanic's tool kit
-

a. REMOVAL

Remove 2 nuts (4), lockwashers (5), bolts (1) and spring bumper (3) from chassis (2). Discard lockwashers.

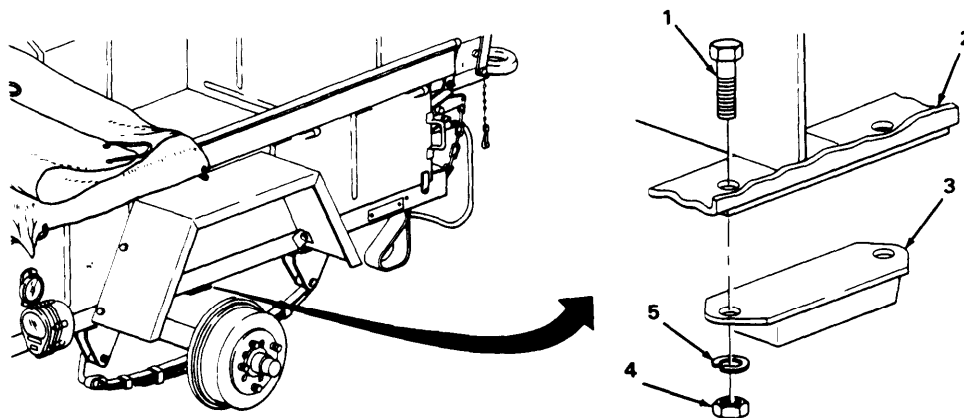

b. INSTALLATION

Install spring bumper (3) on chassis (2) with 2 bolts (1), new lockwashers (5) and nuts (4).

4-45. SHOCK ABSORBER REPLACEMENT.

This Task Covers:

- a. Removal b. Installation

Initial Setup:

Materials/Parts:

- Two cotter pins
- Four bushings
- Four lockwashers

Tools/Test Equipment:

- General mechanic's tool kit

a. REMOVAL

1. Remove 2 cotter pins (6) and discard.
2. Remove 2 washers (5), 4 bushings (4), and shock absorber (7) from bracket (3) and plate assembly (8). Discard bushings.
3. If bracket (3) is damaged, remove 4 nuts (9), lockwashers (10), and screws (1). Remove bracket from framerail (2). Discard lockwashers.

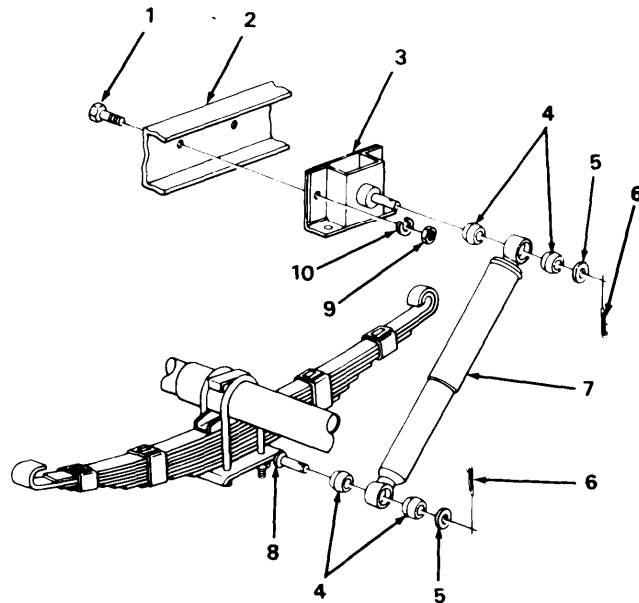

b. INSTALLATION

1. If removed, install bracket (3) on framerail (2) with 4 screws (1), new lockwashers (10), and nuts (9).
2. Install 4 new bushings (4), shock absorber (7), and 2 washers (5) on bracket (3) and plate assembly (8).
3. Secure shock absorber (7) to bracket (3) and plate assembly (8) with 2 new cotter pins (6).

TA503961

Section XII. BODY MAINTENANCE

Paragraph Title	Page Number
Cargo Body Replacement	4-87
Drain Valve Replacement	4-86
Fender Replacement	4-85

4-46. FENDER REPLACEMENT.

This Task Covers:

- | | |
|------------|-----------------|
| a. Removal | b. Installation |
|------------|-----------------|

Initial Setup:

Materials/Parts:

- Five lockwashers

Tools/Test Equipment:

- General mechanic's tool kit

Personnel Required: Two

a. REMOVAL

1. Remove 2 nuts (7), lockwashers (8), 4 flatwashers (9), and 2 screws (11) securing fender (1) to chassis (4). Discard lockwashers.
2. While assistant supports fender (1), remove 3 nuts (6), lockwashers (5), 6 flatwashers (2), and 3 screws (3) securing fender (1) to body (10). Remove fender. Discard lockwashers.

b. INSTALLATION

1. With assistance, position fender (1) for installation.
2. Loosely install fender (1) to body (10) with 3 screws (3), 6 flatwashers (2), 3 new lockwashers (5), and nuts (6).
3. Loosely install fender (1) to chassis (4) with 2 screws (11), 4 flatwashers (9), 2 new lockwashers (8), and nuts (7).
4. Fully tighten 3 nuts (6) and 2 nuts (7).

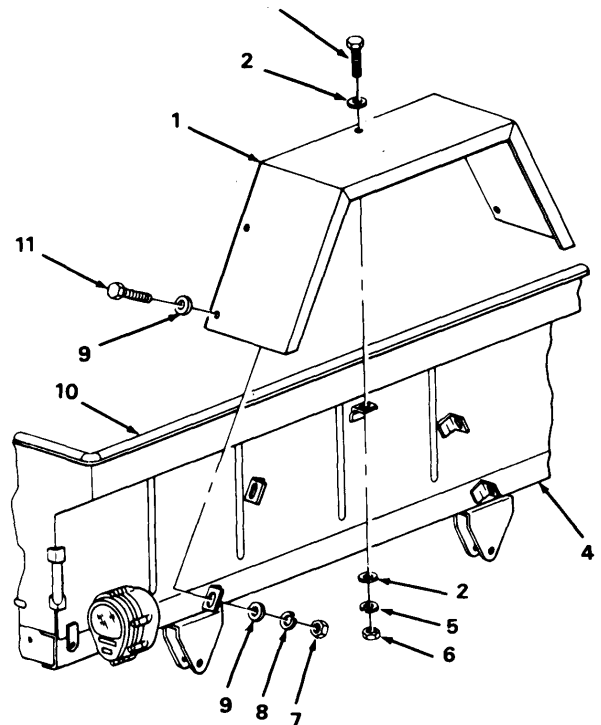

TA503962

4-47. DRAIN VALVE REPLACEMENT.

This Task Covers:

- a. Removal b. Installation
-

Initial Setup:

Materials/Parts:

- Two lockwashers

Tools/Test Equipment:

- General mechanic's tool kit
-

a. REMOVAL

Remove 2 screws (1) and lockwashers (2) from support (4). Remove support and drain valve (3). Discard lockwashers.

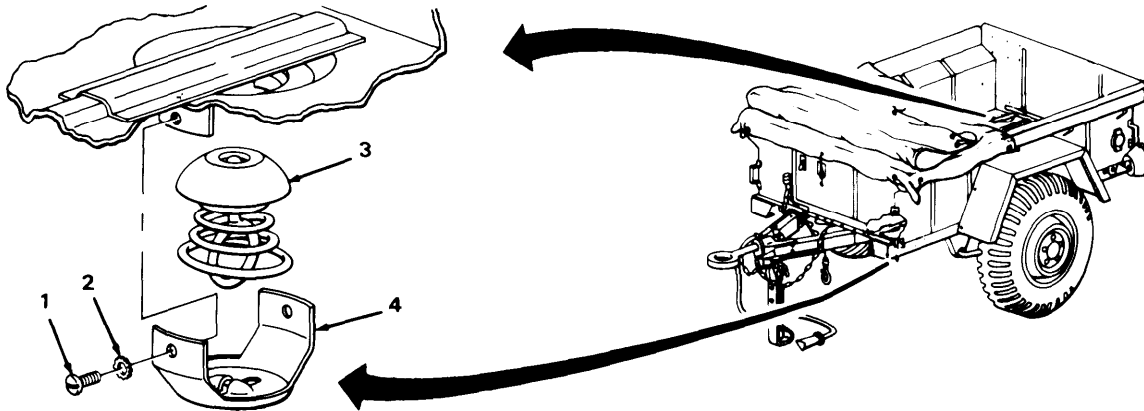

b. INSTALLATION

Install drain valve (3) and support (4) with 2 new lockwashers (2) and screws (1).

4-48. CARGO BODY REPLACEMENT.

This Task Covers:

- | | |
|------------|-----------------|
| a. Removal | b. Installation |
|------------|-----------------|
-

Initial Setup:

Equipment Conditions:

- Fender disconnected from chassis (para 4-46).

Tools/Test Equipment:

- General mechanic's tool kit

Materials/Parts:

- Eight lockwashers

Personnel Required: Two

4-48. CARGO BODY REPLACEMENT (Con't).

WARNING

Stand clear of lifting device when raising or lowering cargo body (1). Failure to follow this warning may result in serious injury to personnel.

1. Remove 8 nuts (6), lockwashers (5), 16 flatwashers (2), and 8 screws (3) securing cargo body (1) to chassis (4). Discard lockwashers,
2. Use a suitable lifting device to lift cargo body (1) from chassis (4),

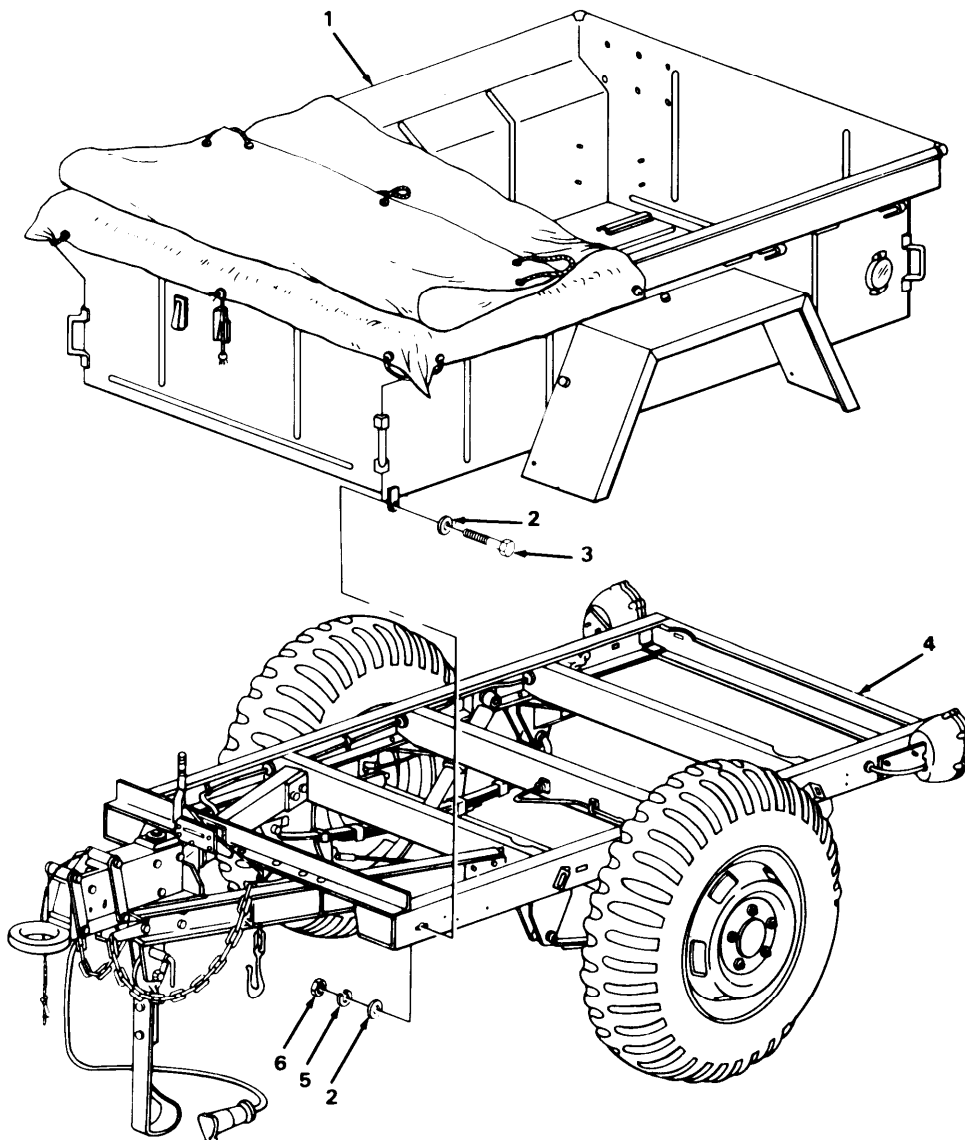

TA503964

4-48. CARGO BODY REPLACEMENT (Con't).

b. INSTALLATION

WARNING

Stand clear of lifting device when raising or lowering cargo body (1). Failure to follow this warning may result in serious injury to personnel.

1. Position cargo body (1) on chassis (4).
2. Secure cargo body (1) to chassis (4) with 8 screws (3), 16 flatwashers (2), 8 new lockwashers (5), and nuts (6).

FOLLOW-ON TASKS:

- Connect fender to chassis (para 4-46).

Section XIII. BODY ACCESSORIES MAINTENANCE

Paragraph Title	Page Number
Identification Plate Replacement	4-91
Reflector Replacement	4-90

4-49. REFLECTOR REPLACEMENT.

This Task Covers:

- | | |
|------------|-----------------|
| a. Removal | b. Installation |
|------------|-----------------|

Initial Setup:

Materials/Parts:

- Two lockwashers

Tools/Test Equipment:

- General mechanic's tool kit

a. REMOVAL

Remove 2 nuts (5) , lockwashers (4), screws (1), flatwashers (2), and reflector (3) from cargo body (6). Discard lockwashers.

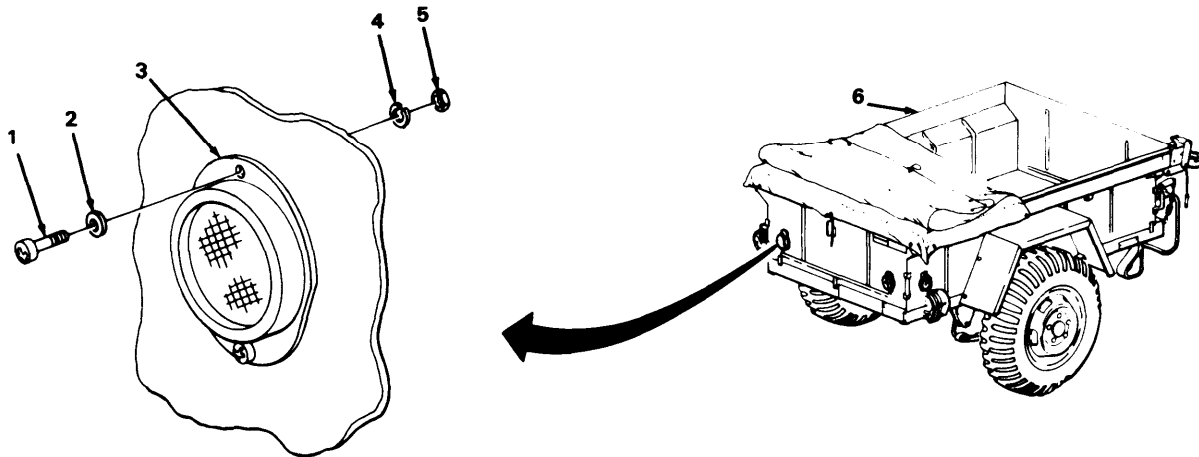

b. INSTALLATION

Install reflector (3) on cargo body (6) with 2 screws (1), flatwashers (2), new lockwashers (4), and nuts (5).

4-50. IDENTIFICATION PLATE REPLACEMENT.

This Task Covers:

a. Removal

b. Installation

Initial Setup:

Materials/Parts:

- Two lockwashers
- Six rivets

Tools/Test Equipment:

- General mechanic's tool kit
 - Common no. 1 shop set
 - Hand riveter, blind
 - Safety goggles
-

a. REMOVAL

1. Remove 2 nuts (4), lockwashers (5), and screws (6) securing identification plate (7) to right side of chassis (8). Remove identification plate. Discard lockwashers.
2. Remove 8 screws (9) and identification plate (10) from rear of chassis (8).

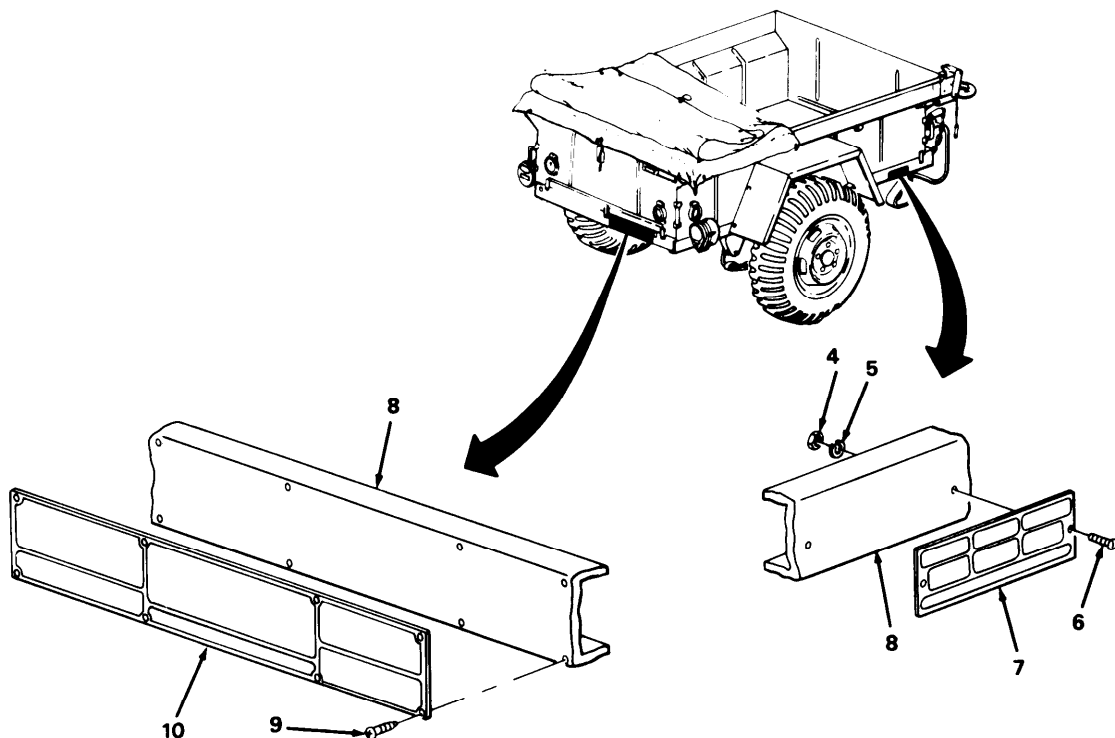

TA503966

4-50. IDENTIFICATION PLATE REPLACEMENT (Con't).

WARNING

Safety goggles must be worn when removing rivets (3) from identification plate (1). Failure to follow this warning may result in serious eye injury.

3. Using hammer and chisel, cut heads off 6 rivets (3). Remove identification plate (1) from cargo body (2).
4. Drive 6 rivet (3) bodies out of cargo body (2). Discard rivets.

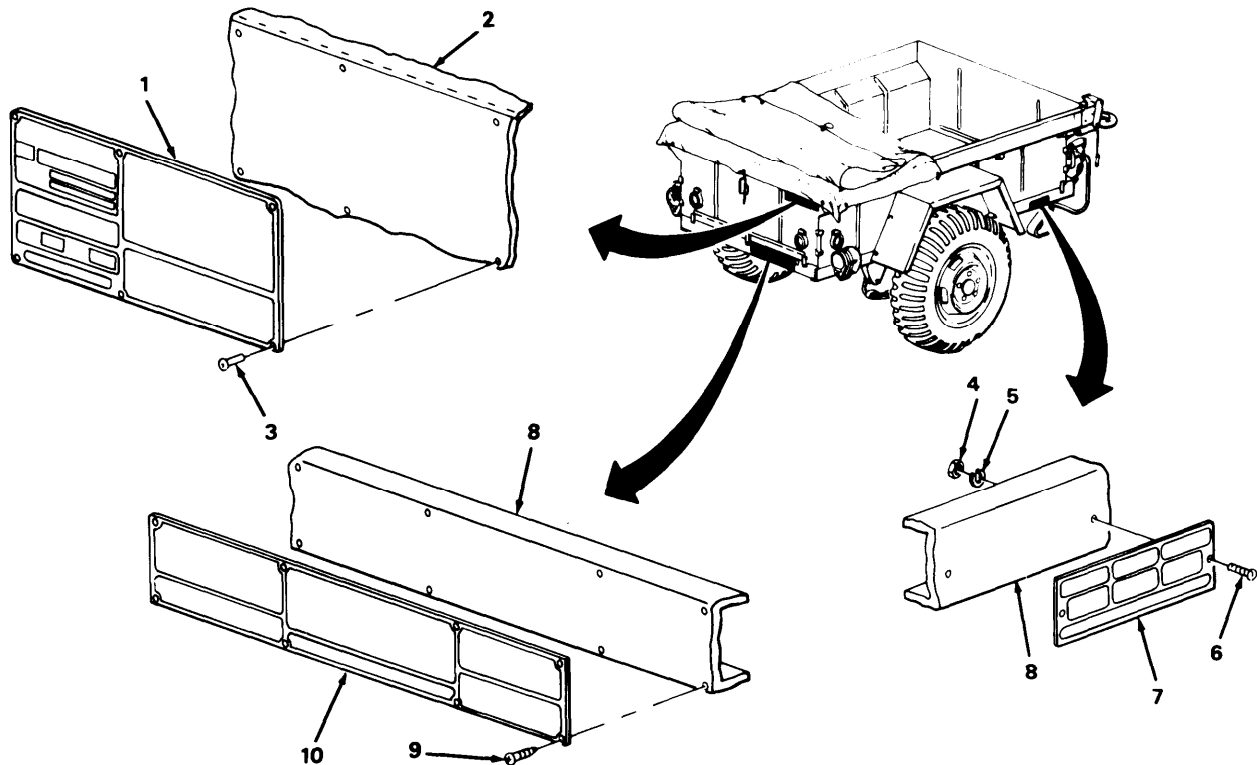

b. INSTALLATION

NOTE

Ensure that information on all plates is legible.

1. Install identification plate (1) on cargo body (2) with 6 new rivets (3).
2. Install identification plate (10) on rear of chassis (8) with 8 screws (9).
3. Install identification plate (7) on right side of chassis (8) with 2 screws (6), new lockwashers (5), and nuts (4).

TA503967

Section XIV. PREPARATION FOR STORAGE OR SHIPMENT

Paragraph Title	Page Number
Care of Equipment in Administrative Storage	4-95
Definition of Administrative Storage	4-93
Exercise Schedule, Table 4-3.	4-96
General	4-93
Preparation of Equipment for Administrative Storage	4-93
Preparation of Equipment for Shipment	4-96
Procedures for Common Components and Miscellaneous Items	4-96
Removal of Equipment from Administrative Storage	4-96

4-51. GENERAL.

- a. This section contains requirements and procedures for administrative storage of equipment that is issued to and in use by Army activities worldwide.
- b. The requirements specified herein are necessary to maintain equipment in administrative storage in such a way as to achieve the maximum readiness condition.
- c. Equipment that is placed in administrative storage should be capable of being readied to perform its mission within a 24-hour period, or as otherwise may be prescribed by the approving authority. Before equipment is placed in administrative storage, a current PMCS should be completed and deficiencies corrected.
- d. Report equipment in administrative storage as prescribed for all reportable equipment.
- e. Perform inspections, maintenance services, and lubrication as specified herein.
- f. Records and reports to be maintained for equipment in administrative storage are those prescribed by DA Pam 738-750 for equipment in use.
- g. A 10% variance is acceptable on time, running hours, or mileage used to determine required maintenance actions.
- h. Accomplishment of applicable PMCS, as mentioned throughout this section, will be on a quarterly basis.

4-52. DEFINITION OF ADMINISTRATIVE STORAGE.

The placement of equipment in administrative storage can be for short periods of time when a shortage of maintenance effort exists. Items should be ready for use within the time factors as determined by the directing authority. During the storage period appropriate maintenance records will be kept.

4-53. PREPARATION OF EQUIPMENT FOR ADMINISTRATIVE STORAGE.

a. Storage Site.

- (1) Select the best available site for administrative storage. Separate stored equipment from equipment in use. Conspicuously mark the area "Administrative Storage".

4-53. PREPARATION OF EQUIPMENT FOR ADMINISTRATIVE STORAGE (Con't).

(2) Covered space is preferred.

(3) Open sites should be improved hardstand, if available. Unimproved sites should be firm, well drained, and free of excessive vegetation.

b. Storage Plan.

(1) Store equipment so as to provide maximum protection from the elements and to provide access for inspection, maintenance, and exercising. Anticipate removal or deployment problems and take suitable precautions.

(2) Take into consideration environmental conditions such as extreme heat or cold; high humidity; blowing sand, dust, or loose debris; soft ground; mud; heavy snows; or any combination thereof, and take adequate precautions.

(3) Establish a fire plan and provide for adequate fire fighting equipment and personnel.

c. Maintenance Service and inspection.

(1) Maintenance Service. Prior to storage, perform the next scheduled organizational PMCS.

(2) Inspection. inspect and approve the equipment prior to storage. Do not place nonmission-capable equipment in storage.

d. Auxiliary Equipment and Basic issue Items.

(1) Process auxiliary equipment and basic issue items simultaneously with the major item to which they are assigned.

(2) If possible, store auxiliary equipment and basic issue items with the major item.

(3) if stored apart from the major item, mark auxiliary equipment and basic issue items with tags indicating the major item, its registration or serial number and location, and store in protective type closures. In addition, place a tag or list indicating the location of the removed items in a conspicuous place on the major item.

e. Correction of Shortcomings and Deficiencies. Correct all shortcomings and deficiencies prior to storage, or obtain a deferment from the approving authority.

f. Lubrication. Lubricate equipment in accordance with instructions in Chapter 3, Section 1.

g. General Cleaning, Painting, and Preservation.

CAUTION

Do not direct water or steam, under pressure, against unsealed electrical systems, or any exterior opening if it will damage a component.

(1) **Cleaning.** Clean the equipment of dirt, grease, and other contaminants but do not use vapor decreasing.

(2) **Painting.** Remove rust and damaged paint by scraping, wire brushing, sanding, or buffing. Sand to a smooth finish and spot paint as necessary (TB 43-0209).

(3) **Preservation.** After cleaning and drying, immediately coat unpainted metal surfaces with an oil or grease, as appropriate (Chapter 3, Section I).

4-53. PREPARATION OF EQUIPMENT FOR ADMINISTRATIVE STORAGE (Con't).**CAUTION**

Place a piece of barrier material (Item 1, Appendix E) between desiccant bags and metal surfaces to prevent corrosion.

NOTE

Air circulation under draped covers reduces deterioration from moisture and heat.

(4) Weatherproofing. Sunlight, heat, moisture (humidity), and dirt tend to accelerate deterioration. Install all covers (including vehicle protective closures) authorized for the equipment. Close and secure all openings except those required for venting and draining. Seal openings to prevent the entry of rain, snow, or dust. Insert desiccant when complete seal is required. Place equipment and provide blocking or framing to allow for ventilation and water drainage. Support cover away from item surfaces that may rust, rot, or mildew.

4-54. CARE OF EQUIPMENT IN ADMINISTRATIVE STORAGE.

a. **Maintenance Services.** After equipment has been placed in administrative storage, inspect, service, and exercise as specified herein.

b. **Inspection.** Inspection will usually be visual and must consist of at least a walk-around examination of all equipment to detect any deficiencies. Inspect equipment in open storage weekly and equipment in covered storage monthly. Inspect all equipment immediately after any severe storm or environmental change. The following are examples of things to look for during a visual inspection:

- (1) Low or flat tires,
- (2) Condition of preservatives, seals, and wraps.
- (3) Torn, frayed, or split canvas covers and tops.
- (4) Corrosion or other deterioration.
- (5) Missing or damaged parts.
- (6) Water in compartments.
- (7) Any other readily recognizable shortcomings or deficiencies.

c. **Repair During Administrative Storage.** Keep equipment in an optimum state of readiness. Accomplish the required services and repairs as expeditiously as possible. Whenever possible, perform all maintenance on-site.

d. **Exercising.** Exercise equipment in accordance with Table 4-3 and the following instructions:

(1) Vehicle Major Exercise. Depreserve equipment by removing only that material restricting exercise. Close all drains, remove blocks, and perform all before-operation checks. Couple trailer to towing vehicle and drive for at least 25 mi (40 km). Make several right and left 90° turns. Make several hard braking stops without skidding. Do the following during exercising when it is convenient: operate all other functional components and perform all during- and after-operation checks.

(2) Scheduled Semites. Scheduled services will include inspection per paragraph 4-54b and will be conducted in accordance with Table 4-3. Lubricate in accordance with instructions in Chapter 3, Section 1.

(3) Corrective Action. Immediately take action to correct shortcomings and deficiencies noted. Record inspection and exercise results on DA Form 2404. Record and report all maintenance actions on DA Form 2407. After exercising, restore the preservation to the original condition. Replenish lubricants used during exercising and note the amount on DA Form 2408.

4-54. CARE OF EQUIPMENT IN ADMINISTRATIVE STORAGE (Con't).

Table 4-3. Exercise Schedule.

Weeks	2	4	6	8	10	12	14	16	18	20	22	24
PMCS						X						X
Scheduled Services		X		X		X		X		X		
Major Exercise												X

e. **Rotation.** Rotate items in accordance with any rotational plan that will keep equipment in an operational condition and reduce the maintenance effort.

4-55. PROCEDURES FOR COMMON COMPONENTS AND MISCELLANEOUS ITEMS.

a. **Tires.** Visually inspect tires during each walk-around inspection. This inspection includes checking with a tire gage. Inflate, repair, or replace as necessary those found to be low, damaged, or excessively worn. Mark inflated and repaired tires with chalk for checking at the next inspection.

b. **Seals.** Seals may develop leaks during storage, or shortly thereafter. If leaking persists, refer to the applicable maintenance section in this manual for corrective maintenance procedures.

4-56. REMOVAL OF EQUIPMENT FROM ADMINISTRATIVE STORAGE.

a. **Activation.** Restore the equipment to normal operating condition in accordance with the instructions contained in Chapter 4, Section II.

b. **Servicing.** Resume the maintenance service schedule in effect at the commencement of storage, or service the equipment before the scheduled dates in order to produce a staggered maintenance workload.

4-57. PREPARATION OF EQUIPMENT FOR SHIPMENT.

a. Refer to TM 55-200, TM 55-601, and TM 743-200-1 for additional instructions on processing, storage, and shipment of materiel.

b. Trailers that have been removed from storage for shipment do not have to be reprocessed if they will reach their destination within the administrative storage period. Reprocess only if inspection reveals any corrosion, or if anticipated in-transit weather conditions make it necessary.

c. When a trailer is received and has already been processed for domestic shipment, as indicated on DD Form 1397, the trailer does not have to be reprocessed for storage unless corrosion and deterioration are found during the inspection upon receipt. List on SF 364 all discrepancies found because of poor preservation, packaging, packing, marking, handling, loading, storage, or excessive preservation. Repairs that cannot be handled by the receiving unit must have tags attached listing the needed repairs. A report of these conditions will be submitted by the unit commander for action by an ordnance maintenance unit.

CHAPTER 5

DIRECT SUPPORT AND GENERAL SUPPORT MAINTENANCE

Section 1. BRAKESHOE MAINTENANCE

5-1. BRAKESHOE REPAIR (M416).

This Task Covers:

- | | |
|--|---|
| <ul style="list-style-type: none"> a. Disassembly b. Cleaning and Inspection | <ul style="list-style-type: none"> c. Assembly |
|--|---|
-

Initial Setup:

Equipment Conditions:

- Brakeshoes removed (para 4-30).

Tools/Test Equipment:

- General mechanic's tool kit
- Field automotive shop set
- Brake and clutch reliner

Materials/Parts:

- Dry cleaning solvent (Item 10, Appendix E)
 - Two friction linings
 - Twenty rivets
-

a. DISASSEMBLY

WARNING

DO NOT handle brakeshoes, brakedrums, or other brake components unless area has been properly cleaned. There may be asbestos dust on these components which can be dangerous if you touch it or breathe it. Wear an approved filter mask and gloves. Never use compressed air or a dry brush to clean brake components. Dust may be removed using an industrial-type vacuum cleaner. Clean dust or mud away from brake components with water and a wet, soft brush or cloth. Failure to follow this warning may result in serious illness or death to personnel.

5-1. BRAKESHOE REPAIR (M416) (Con't).

WARNING

Do not grind rivet (1) heads off of brakeshoes (3) when removing friction linings (4). Asbestos dust from friction linings is hazardous to your health.

NOTE

This procedure describes replacement of friction linings (4) from 1 set of brakeshoes (3). If friction linings are bonded, no repair is authorized.

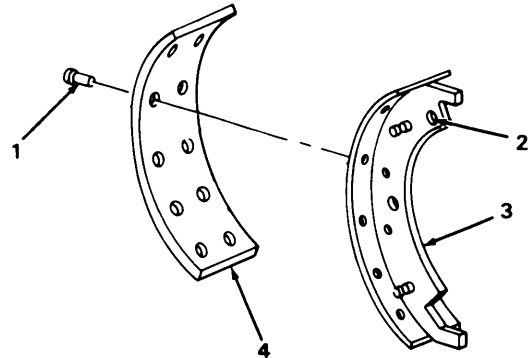

1. Remove 10 rivets (1) and friction lining (4) from brakeshoe (3). Discard rivets and friction lining.
2. Repeat step 1 to remove friction lining (4) from other brakeshoe (3).

WARNING

- **DO NOT** handle brakeshoes, brakedrums, or other brake components unless area has been properly cleaned. There may be asbestos dust on these components which can be dangerous if you touch it or breathe it. Wear an approved filter mask and gloves. Never use compressed air or a dry brush to clean brake components. Dust may be removed using an industrial-type vacuum cleaner. Clean dust or mud away from brake components with water and a wet, soft brush or cloth. Failure to follow this warning may result in serious illness or death to personnel.
- Dry cleaning solvent P-D-680 is toxic and flammable. Always wear protective goggles and gloves, and use only in a well-ventilated area. Avoid contact with skin, eyes, and clothes, and **DO NOT** breathe vapors. **DO NOT** use near open flame or excessive heat. The solvent's flash point is 100°F-130°F (38°C-59°C). If you become dizzy while using cleaning solvent, immediately get fresh air and medical help. If solvent contacts eyes, immediately wash your eyes and get medical aid.

1. Clean brakeshoes with dry cleaning solvent. Dry thoroughly.
2. Visually check brakeshoes (3) for cracks and distortion, Discard brakeshoes if cracked or distorted.
3. Visually check pivot holes (2) for excessive wear, Discard brakeshoes if pivot holes are excessively worn.

c. ASSEMBLY

1. Install new friction lining (4) on brakeshoe (3) with 10 new rivets (1),
2. Repeat step 1 to install new friction lining (4) on other brakeshoe (3).

FOLLOW-ON TASKS:

- Install brakeshoes (para 4-30).

Section II. WHEELS, HUBS, AND BRAKEDRUMS MAINTENANCE

Paragraph Title	Page Number
Brakedrum Repair.....	5 - 3
Tire Repair	5 - 4

5-2. BRAKEDRUM REPAIR

This Task Covers:

a. Inspection

b. Repair

Initial Setup:

Equipment Conditions:

- Hub and brakedrum removed (para 4-36 or 4-37).

Tools/Test Equipment:

- General mechanic's tool kit
- Field automotive shop set
- Brakedrum lathe
- Dial indicator
- Inside micrometer, with extension

a. INSPECTION

1. Visually check stud holes (2) in brakedrum (1) for cracks. Discard brakedrum with cracked stud holes.

2. Visually check braking surface (6) for cracks (3), heat checking (4), and scoring (5). Reface braking surface if damaged (subpara b).

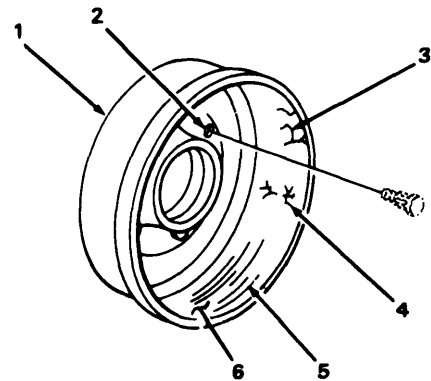

5-2. BRAKEDRUM REPAIR (Con't).

3. Check for out-of-round condition at 45° intervals. Maximum out-of-round is 0.01 in. (0.25 mm).
4. Check brakedrum (1) for tapered condition. Maximum taper is 0.0004 in. (0.01 mm).

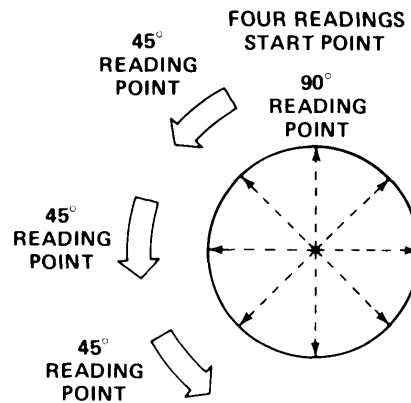

b. REPAIR

WARNING

DO NOT use a brakedrum that exceeds maximum wear specifications. Failure to follow this warning may result in brake failure and serious injury or death.

1. Reface braking surface (6) to remove all cracks (3), heat checking (4), and scoring (5). Remove a maximum of 0.01 in. (0.25 mm) per cut.
2. Discard brakedrum (1) with edge cracks or if inside diameter exceeds 13.20 in. (33.53 cm).

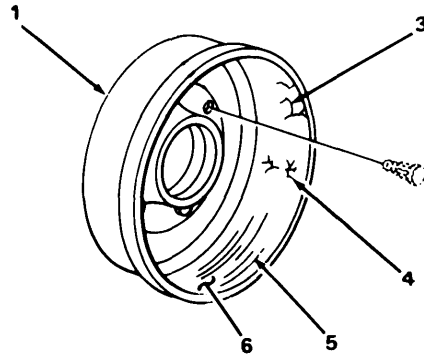

5-3. TIRE REPAIR.

Repair tires in accordance with TM 9-2610-200-24.

TA503970

Section III. FRAME MAINTENANCE

5-4. FRAME REPAIR.

- a. Repair of frame consists of welding, straightening, and reconditioning of damaged parts.
- b. Repair frame in accordance with TB 9-2300-247-40 and TM 9-237.

Section IV. BODY MAINTENANCE

5-5. BODY REPAIR.

- a. Repair of body and fenders consists of welding, straightening, and reconditioning of damaged parts.
- b. Repair body and fenders in accordance with TM 9-237 and TM 43-0139.

APPENDIX A REFERENCES

A-1 . SCOPE.

This appendix lists all forms, field manuals, technical bulletins, technical manuals, and other publications referenced in this manual and which apply to the operation and maintenance of the M416 and M416A1 Cargo Trailers.

A-2. PUBLICATION INDEX.

DA Pam 25-30, *Consolidated Index of Army Publications and Blank Forms* should be consulted frequently for latest changes or revisions and for new publications relating to materiel covered in this technical manual.

A-3. FORMS.

Refer to DA Pam 738-750, *The Army Maintenance Management System (TAMMS)*, for instructions on the use of maintenance forms.

Equipment Inspection and Maintenance Worksheet	DA Form 2404
Equipment Log Assembly (Records).	DA Form 2408
Maintenance Request	DA Form 2407
Preventive Maintenance Schedule and Record	DD Form 314
Processing and Reprocessing Record for Shipment, Storage, and Issue of Vehicles and Spare Engines	DD Form 1397
Product Quality Deficiency Report.	SF 368
Recommended Changes to Equipment Technical Publications	DA Form 2028-2
Recommended Changes to Publications and Blank Forms	DA Form 2028
Report of Discrepancy (ROD)	SF364

A-4. FIELD MANUALS.

Army Motor Transport Units and Operations	FM 55-30
Basic Cold Weather Manual.. . . .	FM31-70
Camouflage	5-20
Desert Operations	90-3
First Aid for Soldiers.	FM 21-11
Manual for the Wheeled Vehicle Driver	FM 21-305
NBC Decontamination	FM 3-5
Northern Operations	FM 31-71
Operation and Maintenance of Ordnance Materiel in Cold Weather (0°to-65°F)	FM 9-207

A-5. TECHNICAL BULLETINS.

Brake Fluid, Silicone (BFS) Conversion Procedures for Tank Automotive Equipment	TB43-0002-87
Color, Marking, and Camouflage Painting of Military Vehicles, Construction Equipment, and Materials Handling Equipment	TB 43-0209
Tactical Wheeled Vehicles: Repair of Frames	TB 9-2300-247-40

A-6. TECHNICAL MANUALS.

Deepwater Fording of Ordnance Materiel TM9-238
Inspection, Care, and Maintenance of Antifriction Bearings TM 9-214
Materials Used for Cleaning, Preserving, Abrading, and
Cementing Ordnance Materiel and Related Items, Including Chemicals TM9-247
Operator's Manual for Welding Theory and Application TM9-237
Operator's, Organizational, Direct Support and General Support
Maintenance Manual Including Repair Parts List for
Filler and Bleeder (EIS DIV- Parker Hannifin Corp.,
Model T3401GVT-01) (NSN4910-00-273-3658) TM 9-4910-709-14&P
Organizational, Direct Support, and General Support, Maintenance, Care, Maintenance,
and Repair of Pneumatic Tires and Inner Tubes TM 9-2610-200-24
Painting instructions for Field Use TM 43-0139
Procedures for Destruction of Tank-Automotive Equipment
to Prevent Enemy Use. TM 750-244-6
Railcar Loading Procedures. TM 55-601
Railway Operating and Safety Rules TM 55-200
Storage and Materials Handling TM 743-200-1

A-7. OTHER PUBLICATIONS,

Army Logistics Readiness and Sustainability AR 700-138
Army Medical Department Expendable/Durable Items CTA 8-100
Expendable/Durable Items (Except Medical, Class V, Repair Parts,
and Heraldic items) CTA 50-970

APPENDIX B MAINTENANCE ALLOCATION CHART

Section I. INTRODUCTION

B-1. GENERAL.

a. This section provides a general explanation of all maintenance and repair functions authorized at the various maintenance levels.

b. The Maintenance Allocation Chart (MAC) in Section II designates overall authority and responsibility for the performance of maintenance functions on the identified end item or component. The application of the maintenance functions to the end item or component will be consistent with the capacities and capabilities of the designated maintenance levels.

c. Section III lists the tools and test equipment (both special tools and common tool sets) required for each maintenance function as referenced from Section II.

d. Section IV contains supplemental instructions and explanatory notes for a particular maintenance function.

B-2. MAINTENANCE FUNCTIONS.

Maintenance functions will be limited to and defined as follows:

a. **Inspect.** To determine the serviceability of an "item by comparing its physical, mechanical, and/or electrical characteristics with established standards through examination (e. g., by sight, sound, or feel).

b. **Test.** To verify serviceability by measuring the mechanical, pneumatic, hydraulic, or electrical characteristics of an item and comparing those characteristics with prescribed standards.

c. **Service.** Operations required periodically to keep an item in proper operating condition, i.e., to clean (includes decontaminate, when required), to preserve, to drain, to paint, or to replenish fuel, lubricants, chemical fluids, or gases.

d. **Adjust.** To maintain or regulate, within prescribed limits, by bringing into proper or exact position, or by setting operating characteristics to specified parameters.

e. **Aline.** To adjust specified variable elements of an item to bring about optimum or desired performance.

f. **Calibrate.** To determine and cause corrections to be made or to be adjusted on instruments or test, measuring, and diagnostic equipments used in precision measurement. Consists of comparisons of two instruments, one of which is a certified standard of known accuracy, to detect and adjust any discrepancy in the accuracy of the instrument being compared.

g. **Remove/install.** To remove and install the same item when required to perform service or other maintenance functions. Install may be the act of emplacing, seating, or fixing into position a spare, repair part, or module (component or assembly) in a manner to allow the proper functioning of an equipment or system.

h. **Replace.** To remove an unserviceable item and install a serviceable counterpart in its place. "Replace" is authorized by the MAC and is shown as the third position of the SMR code.

i. **Repair.** The application of maintenance services, including fault location/troubleshooting, removal/installation, and disassembly/assembly procedures, and maintenance actions to identify troubles and restore serviceability to an item by correcting specific damage, fault, malfunction, or failure in a part, subassembly, module (component or assembly), end item, or system.

B-2. MAINTENANCE FUNCTIONS (Con't).

j. **Overhaul.** That maintenance effort (service/action) prescribed to restore an item to a completely serviceable/operational condition as required by maintenance standards in appropriate technical publications (i. e., DMWR). Overhaul is normally the highest degree of maintenance performed by the Army. Overhaul does not normally return an item to like new condition.

k. **Rebuild.** Consists of those services/actions necessary for the restoration of unserviceable equipment to a like new condition in accordance with original manufacturing standards. Rebuild is the highest degree of materiel maintenance applied to Army equipment. The rebuild operation includes the act of returning to zero those age measurements (hours/miles, etc.) considered in classifying Army equipment/components.

B-3. EXPLANATION OF COLUMNS IN THE MAC, SECTION II.

a. **Column 1, Group Number.** Column 1 lists functional group code numbers, the purpose of which is to identify maintenance significant components, assemblies, subassemblies, and modules with the next higher assembly. End item group number shall be "00,"

b. **Column 2, Component/Assembly.** Column 2 contains the names of components, assemblies, subassemblies, and modules for which maintenance is authorized.

c. **Column 3, Maintenance Function.** Column 3 lists the functions to be performed on the item listed in Column 2. (For a detailed explanation of these functions, refer to paragraph B-2.)

d. **Column 4, Maintenance Level.** Column 4 specifies, by the listing of a work the figure in the appropriate subcolumn(s), the level of maintenance authorized to perform the function listed in Column 3, This figure represents the active time required to perform that maintenance function at the indicated level of maintenance. If the number or complexity of the tasks within the listed maintenance function vary at different maintenance levels, appropriate work time figures will be shown for each level. The work time figure represents the average time required to restore an item (assembly, subassembly, component, module, end item, or system) to a serviceable condition under typical field operating conditions. This time includes preparation time (including any necessary disassembly/assembly time), troubleshooting/fault location time, and quality assurance/quality control time in addition to the time required to perform the specific tasks identified for the maintenance functions authorized in the Maintenance Allocation Chart. The symbol designations for the various maintenance levels are as follows:

- C Unit (Operator or Crew)
- O Unit Organizational Maintenance
- F Direct Support Maintenance
- H General Support Maintenance
- D Depot Maintenance

e. **Column 5, Tools and Equipment.** Column 5 specifies, by code, those common tool sets (not individual tools) and special tools, TMDE, and support equipment required to perform the designated function.

f. **Column 6, Remarks.** This column shall, when applicable, contain a letter code, in alphabetic order, which shall be keyed to the remarks contained in Section IV.

B-4. EXPLANATION OF COLUMNS IN TOOL AND TEST EQUIPMENT REQUIREMENTS, SECTION III.

a. **Column 1, Tool or Test Equipment Reference Code.** The tool and test equipment reference code correlates with a code used in the MAC, Section II, Column 5.

b. **Column 2, Maintenance Level.** The lowest level of maintenance authorized to use the tool or test equipment,

B-4. EXPLANATION OF COLUMNS IN TOOL AND TEST EQUIPMENT REQUIREMENTS, SECTION III (Con't).

c. Column 3, Nomenclature, Name or identification of the tool or test equipment.

d. Column 4, National/NATO Stock Number. The National or NATO Stock Number of the tool or test equipment.

e. Column 5, Tool Number. The manufacturer's part number.

B-5. EXPLANATION OF COLUMNS IN REMARKS, SECTION IV.

a. Column 1, Reference Code. The code recorded in Column 6, Section II.

b. Column 2, Remarks. This column lists information pertinent to the maintenance function being performed as indicated in the MAC, Section II.

Section II. MAINTENANCE ALLOCATION CHART

(1) Group Number	(2) Component/Assembly	(3) Maintenance Function	(4) Maintenance Level					(5) Tools and Equipment	(6) Remarks
			Unit		DS	GS	Depot		
			C	O	F	H	D		
06	ELECTRICAL SYSTEM								
0609	<i>Blackout, Tail and Stoplights</i>	Replace Repair		0.2 0.2				1,2,3 1,2,3	A
	Composite Marker Light Assembly	Replace Repair		0.2 0.2				1,2,3 1,2,3	A
0673	<i>Chassis Wiring Harness</i>	Replace Repair		0.5 0.5				1,2,3 1,2,3	B
	InterVehicular Cable Assembly	Replace Repair		0.2 0.2				1,2,3 1,2,3	B
11	REAR AXLE								
1100	<i>Axle Assembly</i>	Replace		2.5				1,2,3	
12	BRAKES								
1201	<i>Handbrakes</i>								
	Handbrake Lever	Adjust Replace	0.2	1.0				1,2,3	
	Handbrake Linkage and Cables	Service Replace		0.2 1.5				1,2,3 1,2,3	
1202	<i>Service Brakes</i>								
	Brakeshoes and Support Assembly	Adjust Replace Repair		0.2 1.5	0.5			1,2,3 1,2,3 1,4,5,6	c

Section II. MAINTENANCE ALLOCATION CHART (Con't)

(1) Group Number	(2) Component/Assembly	(3) Maintenance Function	(4) Maintenance Level					(5) Tools and Equipment	(6) Remarks
			Unit		DS	GS	Depot		
			C	O	F	H	D		
1204	<i>Hydraulic Brake System</i>								
	Master Cylinder	Service		0.2				1,2,3	
		Replace		1.5				1,2,3	
	Wheel Cylinder	Replace		1.2				1,2,3	
	Hydraulic Lines, Hoses, and Fittings	Replace		1.5				1,2,3	
13	WHEELS								
1311	<i>Wheel Assembly</i>								
	Brakedrum	Replace		1.0				1,2,3,7	
		Repair			1.0			1,4,5,6	
	Wheel Hub	Replace		1.5				1,2,3	
	Wheel Bearing	Service		1.5				1,2,3	
		Adjust		0.5				1,2,3	
		Replace		1.5				1,2,3	
	Oil Seal	Replace		1.5				1,2,3	
1313	<i>Tires and Tubes</i>								
	Tire	Service	0.2						
		Replace		2.0				1,2,3	
		Repair			2.0			1,2,3	
	Tube	Replace		1.3				1,2,3	
		Repair		1.3				1,2,3	
	Wheel	Replace	0.4						
15	FRAME, TOWING ATTACHMENTS, DRAWBARS, AND ARTICULATION SYSTEMS								
1501	<i>Frame Assembly</i>	Repair			4.0			1,4,5,6	
1503	<i>Pintles and Towing Attachments</i>								
	Channels	Replace		1.5				1,2,3	
	Actuator Assembly	Service		0.2				1,2,3	
		Replace		0.8				1,2,3	
		Repair		2.5				1,2,3	

Section II. MAINTENANCE ALLOCATION CHART (Con't)

(1) Group Number	(2) Component/Assembly	(3) Maintenance Function	(4) Maintenance Level					(5) Tools and Equipment	(6) Remarks
			Unit		DS	GS	Depot		
			C	O	F	H	D		
1503	<i>Pintles and Towing Attachments (Con't)</i>								
	Drawbar Coupler	Replace		0.5				1,2,3	
	Chain Assembly	Replace		0.4				1,2,3	
1507	<i>Landing Gear, Leveling Jacks</i>								
	Landing Leg	Service		0.2				1,2,3	
		Replace		0.5				1,2,3	
16	SPRINGS AND SHOCK ABSORBERS								
1601	<i>Springs</i>	Service		0.5				1,2,3	
		Replace		2.5				1,2,3	
1604	<i>Shock Absorber Equipment</i>	Replace		0.6				1,2,3	
18	BODY, CAB, AND HOOD								
1802	<i>Fenders</i>	Replace		2.0				1,2,3	
1804	<i>Drain Valves</i>	Replace		0.5				1,2,3	
1810	<i>Cargo Body</i>	Replace		3.5				1,2,3	
		Repair			3.0			1,4,5,6	G
22	BODY ACCESSORY ITEMS								
2202	<i>Accessory Items</i>								
	Reflectors	Replace		0.2				1,2,3	
2210	<i>Data Plates</i>								
	Identification Plates	Replace		0.2				1,2,3	

Section III. TOOLS AND TEST EQUIPMENT REQUIREMENTS

(1) Tool or Test Equipment Reference Code	(2) Maintenance Level	(3) Nomenclature	(4) National/NATO Stock Number	(5) Tool Number
1	o	Tool Kit, General Mechanic's, Automotive	5180-00-177-7033	
2	0	Shop Equipment, Automotive Maintenance and Repair: organizational Maintenance, Common No. 1, Less Power	4910-00-754-0654	
3	0	Shop Equipment, Automotive Maintenance and Repair: Organizational Maintenance Common No. 2, Less Power	4910-00-754-0650	
4	F	Shop Equipment, Automotive Maintenance and Repair: Field Maintenance, Supplemental No. 1	4910-00-754-0706	
5	F	Tool Kit, Welder's	5180-00-754-0661	
6	F	Shop Equipment, Welding, Field Maintenance	3470-00-357-7268	
7	o	Wrench, Socket, Spindle-nut SPECIAL TOOLS: None	5120-00-596-1370	

Section IV. REMARKS

(1) Reference Code	(2) Remarks
A	Light assembly repair is limited to preformed packing, lamp, and mounting hardware replacement.
B	Chassis wiring harness and intervehicular cable assembly repair is limited to terminal, lug, insulator, shell, and hardware replacement.
C	Brakeshoe repair is limited to friction lining and tubular rivet replacement,
D	Spindle-nut socket wrench is used for M416 trailer only.
E	Brakedrum repair is limited to refacing braking surface using a brakedrum lathe.
F	Refer to TM 9-2610-200-24 for tire and tube repair.
G	Frame, fenders, and body repair consists of welding, straightening, and reconditioning of the damaged part or parts.
H	Actuator assembly repair consists of component part and hardware replacement.

APPENDIX C

COMPONENTS OF END ITEM AND BASIC ISSUE ITEMS LISTS

The M416 and M416A1 Cargo Trailers currently do not have Components of End Item and Basic Issue Items Lists assigned.

APPENDIX D ADDITIONAL AUTHORIZATION LIST

The M416 and M416A1 Cargo Trailers currently do not have an Additional Authorization List assigned.

APPENDIX E

EXPENDABLE/DURABLE SUPPLIES AND MATERIALS LIST

Section 1. INTRODUCTION

E-1. SCOPE.

This appendix lists expendable/durable supplies and materials you will need to operate and maintain the M416 and M416A1 Cargo Trailers. This listing is for informational purposes only and is not authority to requisition the listed items. These items are authorized to you by CTA 50-970, *Expendable/Durable Items (Except Medical, Class V, Repair Parts, and Heraldic Items)* or CTA 8-100, *Army Medical Department Expendable/Durable Items*.

E-2. EXPLANATION OF COLUMNS.

a. Column (1) - Item Number. This number is assigned to the entry in the listing and is referenced in the "Initial Setup" of maintenance paragraphs or narrative instructions to identify the material needed (e.g., Dry cleaning solvent, Item 10, Appendix E).

b. Column (2) - Level. This column identifies the lowest level of maintenance that requires the listed item.

*C - Operator/Crew
O - Organizational Maintenance
F - Direct Support Maintenance
H - General Support Maintenance*

c. Column (3) - National Stock Number. This is the National stock number assigned to the item. Use it to request or requisition the item.

d. Column (4) - Description. Indicates the Federal Item Name and, if required, a description to identify the item. The last line for each item indicates the Commercial and Government Entity (CAGE) in parentheses followed by the part number.

e. Column (5) - Unit of Measure (U/M). Indicates the measure used in performing the actual maintenance function. This measure is expressed by a two-character alphabetical abbreviation (e.g., ea, in., pr). If the unit of measure differs from the unit of issue, requisition the lowest unit of issue that will satisfy your requirements.

SECTION II. EXPENDABLE/DURABLE SUPPLIES AND MATERIALS LIST				
(1)	(2)	(3)	(4)	(5)
ITEM NUMBER	LEVEL	NATIONAL STOCK NUMBER	DESCRIPTION	U/M
1	O		BARRIER MATERIAL, GREASEPROOFED-WATERPROOFED, FLEXIBLE (81349) MIL-B-121	
		8135-00-171-0930	100-YARD ROLL	YD
2	O		BRAKE FLIUD, AUTOMOTIVE (81349) MIL-B-46176	
		9150-01-102-9455	1-GALLON CAN	GL
		9150-01-123-3152	5-GALLONS CAN	GL
		9150-01-072-8379	55-GALLON DRUM	GL
3	O		COMPOUND, SEALING (05972) 088-21	
		8030-00-081-2339	10-CC BOTTLE	CC
4	O		DETERGENT, GENERAL PURPOSE, LIQUID (81349) MIL-D-16791	
		7930-00-282-9699	1-GALLON CAN	GL
5	O		GREASE, AUTOMOTIVE AND ARTILLERY (81349) MIL-G-10924	
		9150-00-935-1017	14-OUNCE CAN	OZ
		9150-00-190-0904	1.75-POUND CSAN	LB
		9150-00-190-0905	6.50-POUND CAN	LB
6	O		OIL, LUBRICATING, OE/HDO-10 (81349) MIL-L-2014	
		9150-00-189-6727	1-QUART CAN	QT
		9150-00-186-6668	5-GALLON CAN	GL
		9150-00-191-2772	55-GALLON DRUM	GL
7	O		OIL, LUBRICATING, OE/HDO-30 (81349) MIL-L-2104	
		9150-00-186-6681	1-QUART CAN	QT
		9150-00-188-9858	5-GALLON CAN	GL
		9150-00-189-6729	55-GALLON DRUM	GL
8	O		OIL, LUBRICATING, OEA (81349) MIL-L-46167	
		9150-00-402-4478	1-QUART CAN	QT
		9150-00-402-2372	5-GALLON CAN	GL
		9150-00-491-7197	55-GALLON DRUN	GL

SECTION II. EXPENDABLE/DURABLE SUPPLIES AND MATERIALS LIST (CON'T)

(1)	(2)	(3)	(4)	(5)
ITEM NUMBER	LEVEL	NATIONAL STOCK NUMBER	DESCRIPTION	U/M
9	C		RAG, WIPING (58536) A-A-531	
		7920-00-205-1711	50-POUND BALE	LB
10	C		SOLVENT, DRY CLEANING (81348) P-D-680, TYPE II	
		6850-00-664-5685	1-QUART CAN	QT
		6850-00-281-1985	1-GALLON CAN	GL
		6850-00-285-8011	55-GALLON DRUM	GL
11	O		TAG, MARKER (81349) MIL-T-12755	
		9905-00-537-8954	50 EACH	EA

APPENDIX F REPAIR PARTS AND SPECIAL TOOLS LISTS

Section I. INTRODUCTION

F-1. SCOPE.

This RPSTL lists and authorizes spares and repair parts; special tools; special test, measurement, and diagnostic equipment (TMDE); and other special support equipment required for performance of organizational, direct support, and general support maintenance of the ¼-Ton Cargo Trailer. It authorizes the requisitioning, issue, and disposition of spares, repair parts, and special tools as indicated by the Source, Maintenance, and Recoverability (SMR) codes.

F-2. GENERAL.

In addition to Section I, *Introduction*, this Repair Parts and Special Tools List is divided into the following sections:

a. Section II. Repair Parts List. A list of spares and repair parts authorized by this RPSTL for use in the performance of maintenance. The list also includes parts which must be removed for replacement of the authorized parts. Parts lists are composed of functional groups in ascending alphanumeric sequence, with the parts in each group listed in ascending figure and item number sequence. Bulk materials are listed in item name sequence. Repair parts kits are listed separately in their own functional group within Section II. Repair parts for reparable special tools are also listed in this section. Items listed are shown on the associated illustration (s)/figure (s).

b. Section III. Special Tools List. A list of special tools, special TMDE, and other special support equipment authorized by this RPSTL [as indicated by Basis of Issue (BOI) information in the *DESCRIPTION AND USABLE O/V CODE* column] for the performance of maintenance.

c. Section IV. National Stock Number and Part Number Index. A list, in National Item Identification Number (NIIN) sequence, of all National stock numbered items appearing in the listing, followed by a list in alphanumeric sequence of all part numbers appearing in the listings. National stock numbers and part numbers are cross-referenced to each illustration/figure and item number appearance. The figure and item number index lists figure and item numbers in alphanumeric sequence and cross-references NSN, CAGE, and part numbers.

F-3. EXPLANATION OF COLUMNS (SECTIONS II AND III).

a. ITEM NO. [Column (1)]. Indicates the number used to identify items called out in the illustration.

b. SMR CODE [Column (2)]. The Source, Maintenance, and Recoverability (SMR) code is a 5-position code containing supply/requisitioning information, maintenance category authorization criteria, and disposition instruction, as shown in the following breakout:

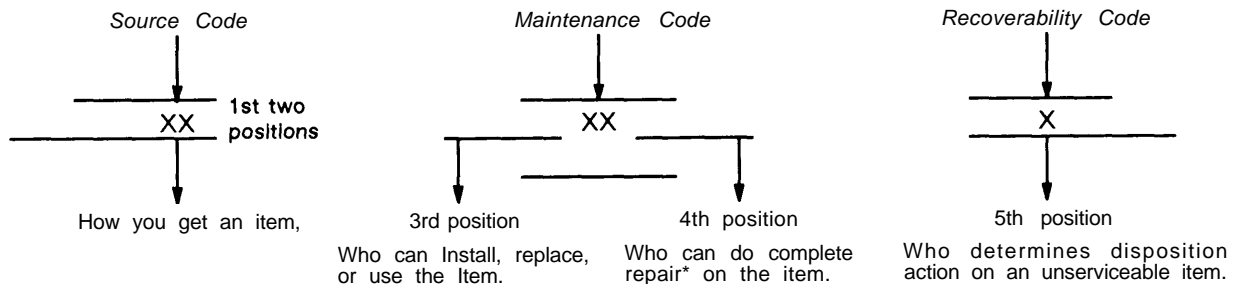

• *Complete Repair:* Maintenance capacity, capability, and authority to perform all corrective maintenance tasks of the "Repair" function in a use/user environment in order to restore serviceability to a failed item.

F-3. EXPLANATION OF COLUMNS (SECTIONS II AND III) (Con't).

(1) **Source Code.** The source code tells you how to get an item needed for maintenance, repair, or overhaul of an end item/equipment. Explanations of source codes follow:

<u>Code</u>	<u>Application/Explanation</u>
<div style="border: 1px solid black; padding: 5px; display: inline-block;"> PA PB PC** PD PE PF PG </div>	<p>Stocked items; use the applicable NSN to request/requisition items with these source codes. They are authorized to the category indicated by the code entered in the 3rd position of the SMR code.</p> <p style="text-align: center;"><i>** Items coded PC are subject to deterioration.</i></p> <p>.....</p>
<div style="border: 1px solid black; padding: 5px; display: inline-block;"> KD KF KB </div>	<p>Items with these codes are not to be requested/requisitioned individually. They are part of a kit which is authorized to the maintenance category indicated in the 3rd position of the SMR code. The complete kit must be requisitioned and applied.</p> <p>.....</p>
<div style="border: 1px solid black; padding: 5px; display: inline-block;"> MO - Made at ORG/ AVUM Level MF - Made at DS/AVUM Level MH - Made at GS Level MD - Made at Depot </div>	<p>Items with these codes are not to be requested/requisitioned individually. They must be made from bulk materiel which is identified by the part number in the <i>DESCRIPTION AND USABLE ON CODE (UOC)</i> column and listed in the bulk materiel group of the repair parts list in this RPSTL. If the item is authorized to you by the 3rd position code of the SMR code, but the source code indicates it is made at a higher level, order the item from the higher level of maintenance.</p> <p>.....</p>
<div style="border: 1px solid black; padding: 5px; display: inline-block;"> AO - Assembled by ORG/AVUM Level AF - Assembled by DS/ AVUM Level AH - Assembled by GS Level AD - Assembled at De- pot </div>	<p>Items with these codes are not to be requested/requisitioned individually. The parts that make up the assembled item must be requisitioned or fabricated and assembled at the level of maintenance indicated by the source code. If the 3rd position code of the SMR code authorizes you to replace the item, but the source code indicates that the item is assembled at a higher level, order the item from the higher level of maintenance.</p>

NOTE

Cannibalization or controlled exchange, when authorized, may be used as a source of supply for items with the above source codes, except for those source coded "XA."

XA - DO NOT requisition an " XA "-coded item. Order its next higher assembly.

XB - If an "XB" item is not available from salvage, order it using the CAGE and part number given.

F-3. EXPLANATION OF COLUMNS (SECTIONS II AND III) (Con't).

- XC - Installation drawing, diagram, instruction sheet, field service drawing, that is identified by manufacturer's part number.
- XD - Item is not stocked. Order an "XD"-coded item through normal supply channels using the CAGE and part number given, if no NSN is available.

(2) **Maintenance Code.** Maintenance codes tell you the level(s) of maintenance authorized to use and repair support items. The maintenance codes are entered in the third and fourth positions of the SMR code as follows:

- (a) The maintenance code entered in the third position tells you the lowest maintenance level authorized to remove, replace, and use an item. The maintenance code entered in the third position will indicate authorization to one of the following levels of maintenance.

<u>Code</u>	<u>Application/Explanation</u>
C	- Crew or operator maintenance done within unit maintenance or aviation unit maintenance.
O	- Organizational maintenance or aviation unit can remove, replace, and use the item.
F	- Direct support or aviation intermediate level can remove, replace, and use the item.
H	- General support level can remove, replace, and use the item.
L	- Specialized repair activity can remove, replace, and use the item.
D	- Depot level can remove, replace, and use the item.

NOTE

Some limited repair may be done on the item at a lower level of maintenance, if authorized by the Maintenance Allocation Chart (MAC) and SMR codes.

- (b) The maintenance code entered in the fourth position tells whether or not the item is to be repaired and identifies the lowest maintenance level with the capability to do complete repair (i. e., perform all authorized "Repair" functions). This position will contain one of the following maintenance codes:

<u>Code</u>	<u>Application/Explanation</u>
O	- Organizational maintenance or aviation unit is the lowest level that can do complete repair of the item.
F	- Direct support or aviation intermediate is the lowest level than can do complete repair of the item.
H	- General support is the lowest level that can do complete repair of the item.
L	- Specialized repair activity is the lowest level that can do complete repair of the item.
D	- Depot is the lowest level that can do complete repair of the item.
Z	- Nonreparable. No repair is authorized.
B	- No repair is authorized. (No parts or special tools are authorized for the maintenance of a "B"-coded item.) However, the item may be reconditioned by adjusting, lubricating, etc., at the user level.

F-3. EXPLANATION OF COLUMNS (SECTIONS II AND III) (Con't).

(3) **Recoverability Code.** Recoverability codes are assigned to items to indicate the disposition action on unserviceable items. The recoverability code is entered in the fifth position of the SMR code as follows:

<u>Code</u>	<u>Application/Explanation</u>
Z	- Nonreparable item. When unserviceable, condemn and dispose of the item at the level of maintenance shown in the 3rd position of the SMR code.
O	- Reparable item, When uneconomically reparable, condemn and dispose of the item at unit maintenance or aviation unit level,
F	- Reparable item. When uneconomically reparable, condemn and dispose of the item at the direct support or aviation intermediate level,
H	- Reparable item. When uneconomically reparable, condemn and dispose of the item at the general support level.
D	- Reparable item. When beyond lower level repair capability, return to depot. Condemnation and disposal of item not authorized below depot level.
L	- Reparable item. Condemnation and disposal of item not authorized below specialized repair activity (SRA).
A	- Item requires special handling or condemnation procedures because of specific reasons (e.g., precious metal content, high dollar value, critical material, or hazardous material). Refer to appropriate manuals/directives for specific instructions.

c. **CAGEC [Column (3)].** The Commercial and Government Entity (CAGE) Code (C) is a 5-digit alphanumeric code which is used to identify the manufacturer, distributor, or Government agency, etc., that supplies the item.

NOTE

When you use an NSN to requisition an item, the item you receive may have a different part number from the part ordered.

d. **PART NUMBER [Column (4)].** Indicates the primary number used by the manufacturer (individual, company, firm, corporation, or Government activity), which controls the design and characteristics of the item by means of its engineering drawings, specifications standards, and inspection requirements to identify an item or range of items.

e. **DESCRIPTION AND USABLE ON CODE (UOC) [Column (5)],** This column includes the following information:

(1) The Federal item name and, when required, a minimum description to identify the item.

(2) Physical security classification. Not Applicable.

(3) Items that are included in kits and sets are listed below the name of the kit or set on Figure KIT.

(4) Spare/repair parts that make up an assembled item are listed immediately following the assembled item line entry.

(5) Part numbers for bulk materials are referenced in this column in the line item entry for the item to be manufactured/fabricated.

(6) When the item is not used with all serial numbers of the same model, the effective serial numbers are shown on the last line(s) of the description (before UOC).

F-3. EXPLANATION OF COLUMNS (SECTIONS II AND III) (Con't).

(7) The usable on code, when applicable. (See paragraph F-5, Special Information)

(8) In the Special Tools List section, the Basis of Issue (BOI) appears as the last line(s) in the entry for each special tool, special TMDE, and other special support equipment. When density of equipments supported exceeds density spread indicated in the Basis of Issue, the total authorization is increased proportionately.

(9) The statement "END OF FIGURE" appears just below the last item description in Column 5 for a given figure in both Section II and Section III.

f. **QTY [Column (6)].** The QTY (quantity per figure) column indicates the quantity of the item used in the breakout shown on the illustration/figure, which is prepared for a functional group, subfunctional group, or an assembly. A "V" appearing in this column in lieu of a quantity indicates that the quantity is variable and the quantity may vary from application to application.

F-4. EXPLANATION OF COLUMNS (SECTION IV).

a. National Stock Number (NSN) Index.

(1) **STOCK NUMBER Column.** This column lists the NSN by National Item Identification Number (NIIN) sequence. The NIIN consists of the last nine digits of the NSN (i.e.,

NSN
5305-01-674-1467). When using this column to locate an item, ignore the first 4 digits of the NSN. However, the complete NSN should be used when ordering items by stock number.

er, the complete NSN should be used when ordering items by stock number.

(2) **FIG. Column.** This column lists the number of the figure where the item is identified/located. The figures are in numerical order in Section II and Section III.

(3) **ITEM Column.** The item number identifies the item associated with the figure listed in the adjacent FIG. column. This item is also identified by the NSN listed on the same line.

b. **Part Number Index.** Part numbers in this index are listed by part number in ascending alphanumeric sequence (i.e., vertical arrangement of letter and number combination which places the first letter or digit of each group in order A through Z, followed by the numbers 0 through 9 and each following letter or digit in like order).

(1) **CAGEC Column.** The Commercial and Government Entity (CAGE) Code (C) is a 5-digit alphanumeric code used to identify the manufacturer, distributor, or Government agency, etc., that supplies the item.

(2) **PART NUMBER Column.** Indicates the primary number used by the manufacturer (individual, firm, corporation, or Government activity), which controls the design and characteristics of the item by means of its engineering drawings, specifications standards and inspection requirements to identify an item or range of items.

(3) **STOCK NUMBER Column.** This column lists the NSN for the associated part number and manufacturer identified in the PART NUMBER and CAGE columns to the left.

(4) **FIG. Column.** This column lists the number of the figure where the item is identified/located in Section II and Section III.

(5) **ITEM Column.** The item number is that number assigned to the item as it appears in the figure referenced in the adjacent figure number column.

F-5. SPECIAL INFORMATION.

a. **Usable On Code.** The usable on code appears in the lower left corner of the Description column heading. Usable on codes are shown as "UOC: " in the Description column (justified left) on the first line applicable item description/nomenclature. Uncoded items are applicable to all models. Identification of the usable on codes used in this RPSTL are:

F-5. SPECIAL INFORMATION (Con't).

<u>Code</u>	<u>Used On</u>
957	M416
U69	M416A1

b. **Fabrication Instructions.** Bulk materials required to manufacture items are listed in the Bulk Materiel Functional Group of this RPSTL. Part numbers for bulk materials are also referenced in the DESCRIPTION column of the line item entry for the item to be manufactured/fabricated. Detailed fabrication instructions for items source coded to be manufactured or fabricated are found in *Appendix G* of this manual.

c. **Assembly Instructions.** Detailed assembly instructions for items source coded to be assembled from component spare/repair parts are found in *Chapters 4* and *5*. Items that make up the assembly are listed immediately following the assembly item entry or reference is made to an applicable figure.

d. **Kits.** Line item entries for repair parts kits appear in group 9401 in Section II. Not Applicable.

e. **Index Numbers.** Items which have the word BULK in the FIG. column will have an index number shown in the item column. This index number is a cross-reference between the National Stock Number/Part Number Index and the bulk materiel list in Section II.

F-6. HOW TO LOCATE REPAIR PARTS.

a. **When National Stock Number or Part Number is Not Known:**

(1) **First.** Using the Table of Contents, determine the assembly group or subassembly group to which the item belongs. This is necessary since figures are prepared for assembly groups and subassembly groups, and listings are divided into the same groups.

(2) **Second.** Find the figure covering the assembly group or subassembly group to which the item belongs.

(3) **Third.** Identify the item on the figure and use the Figure and Item Number Index to find the NSN.

b. **When National Stock Number or Part Number is Known:**

(1) **First.** Using the National Stock Number or Part Number Index, find the pertinent National Stock Number or Part Number. The NSN Index is in National Item Identification Number (NIIN) sequence [see paragraph F-4.a(1)]. The part numbers in the Part Number Index are listed in ascending alphanumeric sequence (see paragraph F-4.b). Both indexes cross-reference you to the illustration/figure and item number of the item you are looking for.

(2) **Second.** Turn to the figure and item number, verify that the item is the one you're looking for, then locate the item number in the repair parts list for the figure.

F-7. ABBREVIATIONS.

For standard abbreviations see MIL-STD-12D, *Military Standard Abbreviations for Use on Drawings, Specifications, Standards, and in Technical Documents.*

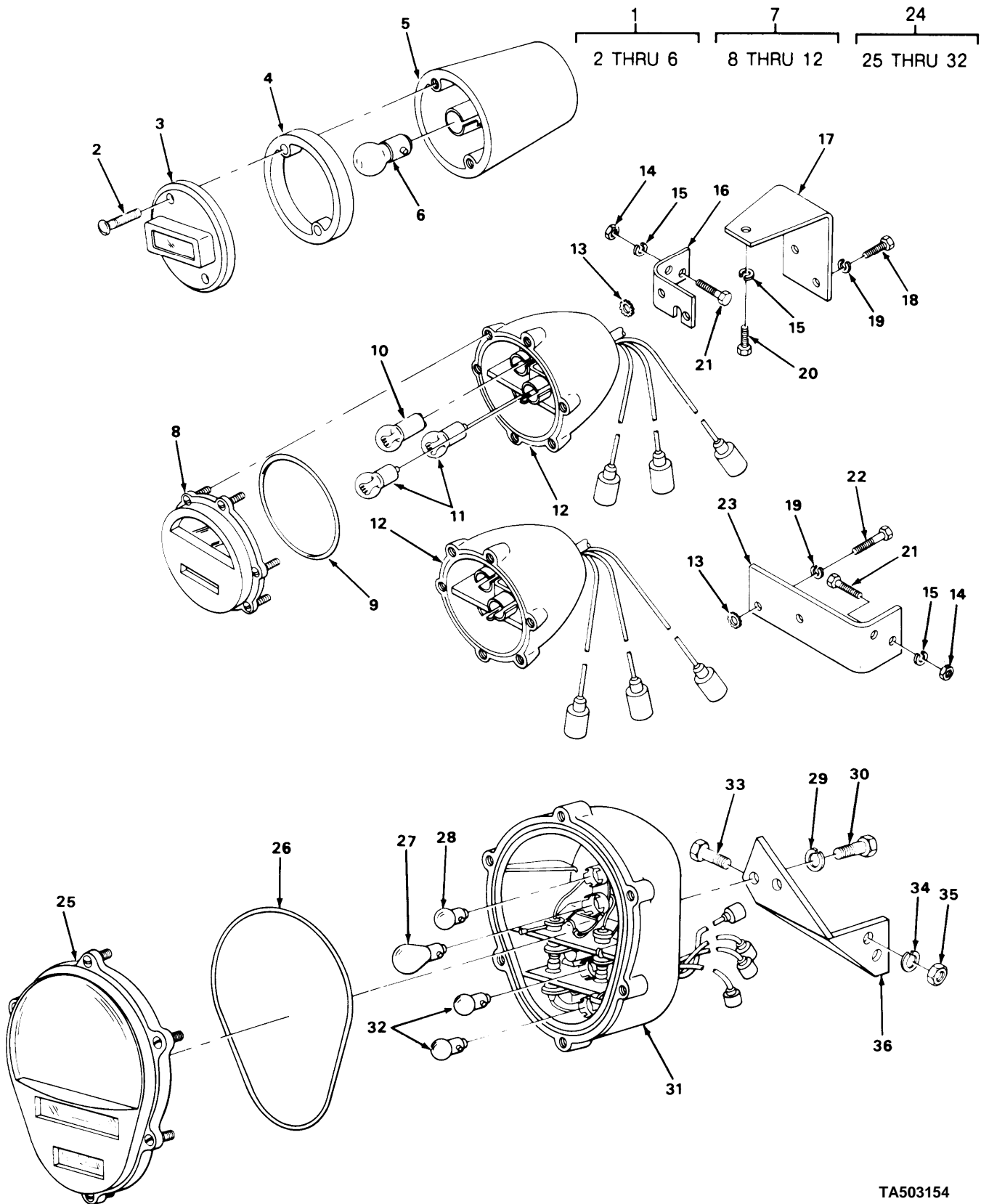
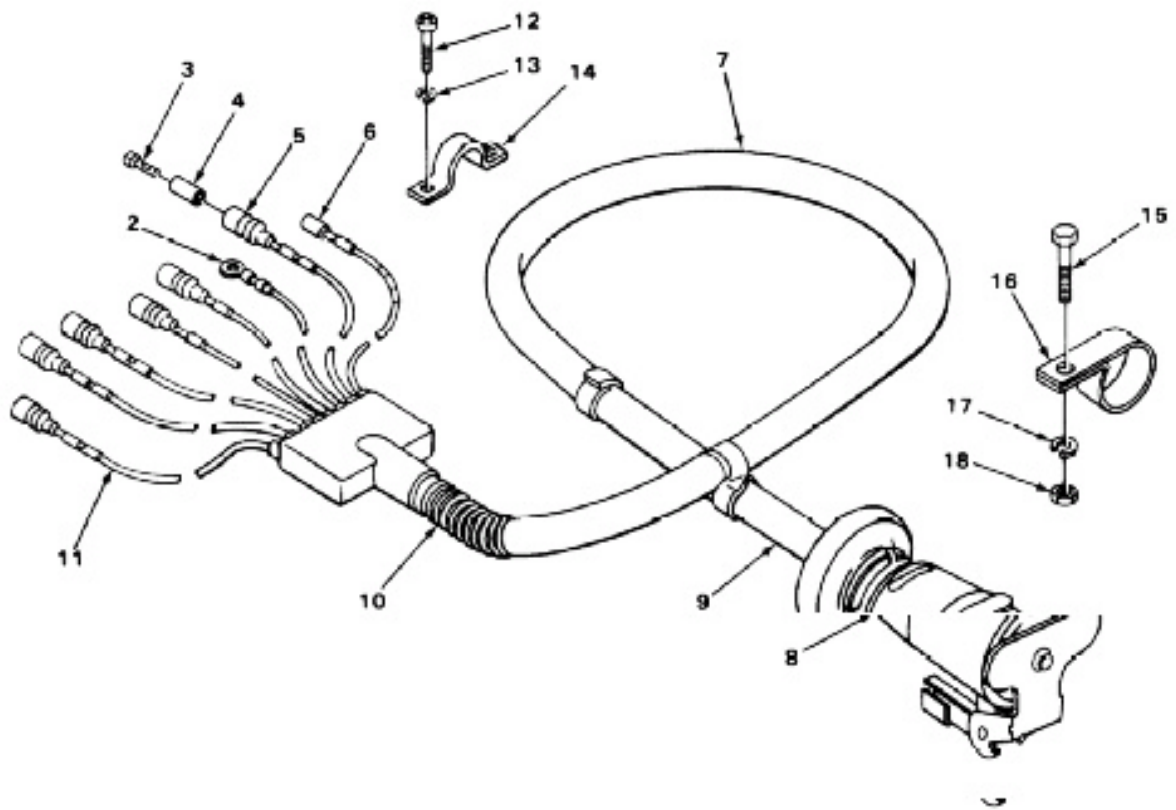

FIGURE 1. TAILLIGHT, BLACKOUT LIGHT, AND COMPOSITE MARKER LIGHT ASSEMBLIES.

SECTION II		TM9-2330-251-14&P			
(1)	(2)	(3)	(4)	(5)	(6)
ITEM	SMR		PART		
NO	CODE	CAGEC	NUMBER	DESCRIPTION AND USABLE ON CODES (UOC)	QTY
GROUP 06 ELECTRICAL SYSTEM					
GROUP 0609 LIGHTS					
FIG. 1 TAILLIGHT, BLACKOUT LIGHT, AND COMPOSITE MARKER LIGHT ASSEMBLIES					
1	PAOOO	96906	MS51302-1	STOP LIGHT,VEHICULA UOC:957	1
2	PAOZZ	96906	MS51959-46	.SCREW UOC:957	2
3	PAOZZ	19207	8741646	.RETAINER,LENS UOC:957	1
4	PAOZZ	73331	5942528	.GASKET UOC:957	1
5	PAOZZ	19207	8741650	.HOUSING,LIGHT UOC:957	1
6	PAOZZ	96906	MS15570-1251	.LAMP,INCANDESCENT UOC:957	1
7	PAOOO	19207	8378785	STOP LIGHT-TAILLIGHT UOC:957	2
8	XDOZZ	18355	7526020	.DOOR ASSEMBLY UOC:957	1
9	PAOZZ	19207	7320658	.PACKING,PREFORMED UOC:957	1
10	PAOZZ	96906	MS35478-1683	.LAMP,INCANDESCENT UOC:957	1
11	PAOZZ	96906	MS15570-1251	.LAMP,INCANDESCENT UOC:957	2
12	PAOZZ	96906	MS53047-1	.LIGHT,PARKING UOC:957	1
13	PAOZZ	96906	MS45904-76	WASHER UOC:957	4
14	PAOZZ	96906	MS51968-8	NUT,PLAIN,HEXAGON UOC:957	4
15	PFOZZ	96906	MS35338-45	WASHER,LOCK UOC:957	5
16	PAOZZ	19207	7328268	BRACKET,ANGLE UOC:957	1
17	PAOZZ	19207	10924588	BRACKET RIGHT SIDE UOC:957	1
18	PAOZZ	96906	MS35291-59	SCREW UOC:957	2
19	PAOZZ	96906	MS35338-46	WASHER,LOCK UOC:957	4
20	XDOZZ	19207	11721	SCREW UOC:957	1
21	XDOZZ	19207	120741	SCREW UOC:957	4
22	PFOZZ	96906	MS18154-58	SCREW,CAP HEXAGON H UOC:957	2

SECTION II				TM9-2330-251-14&P	
(1)	(2)	(3)	(4)	(5)	(6)
ITEM	SMR		PART		
NO	CODE	CAGEC	NUMBER	DESCRIPTION AND USABLE ON CODES (UOC)	QTY
23	PAOZZ	19207	7328267	BRACKET, ANGLE UOC:957	1
24	PAOOO	96906	MS52125-2	LIGHT, COMPOSITE UOC:U69	2
25	XAOZZ	19207	11639535	.DOOR AND LENS ASSY UOC:U69	1
26	PAOZZ	19207	11639519-2	.PACKING, PREFORMED UOC:U69	1
27	PAOZZ	96906	MS35478-1683	.LAMP, INCANDESCENT UOC:U69	1
28	PAOZZ	96906	MS15570-623	.LAMP, INCANDESCENT UOC:U69	1
29	PAOZZ	96906	MS35338-46	.WASHER, LOCK UOC:U69	2
30	PAOZZ	96906	MS18154-58	.SCREW, CAP, HEXAGON H UOC:U69	2
31	XADZZ	19207	11639520	.BODY ASSEMBLY UOC:U69	1
32	PAOZZ	96906	MS15570-1251	.LAMP, INCANDESCENT UOC:U69	2
33	PAOZZ	96906	MS90727-32	BOLT, MACHINE UOC:U69	4
34	PAOZZ	96906	MS35338-45	WASHER, LOCK UOC:U69	4
35	PAOZZ	96906	MS51968-5	NUT, PLAIN, HEXAGON UOC:U69	4
36	PAOZZ	19207	11625310-1	BRACKET, ANGLE TAIL LIGHT LEFT HAND UOC:U69	1
36	PFOZZ	19207	11625310-2	BRACKET, ANGLE TAIL LIGHT RIGHT HAND UOC:U69	1

END OF FIGURE



TA503155

FIGURE 2. INTERVEHICULAR CABLE ASSEMBLY.

SECTION II		TM9-2330-251-14&P			
(1)	(2)	(3)	(4)	(5)	(6)
ITEM	SMR		PART		
NO	CODE	CAGEC	NUMBER	DESCRIPTION AND USABLE ON CODES (UOC)	QTY
				GROUP 0613 HULL OR CHASSIS WIRING HARNESS	
				FIG. 2 INTERVEHICULAR CABLE ASSEMBLY	
1	PAOOO	19207	8722864	CABLE ASSEMBLY,POWE ELECTRICAL	1
2	XAOZZ	96906	MS25036-154	.TERMINAL, LUG GROUND	1
3	XAOZZ	19207	8338564	.TERMINAL ASSEMBLY FEMALE	7
4	XAOZZ	19207	8338562	.INSULATOR, BUSHING CABLE ASSEMBLY	7
5	XAOZZ	19207	8338561	.SHELL, ELECTRICAL MALE, SINGLE	7
6	XAOZZ	81349	M43436-1-1	.BAND,MARKER	13
7	XAOZZ	81349	M13486/10-1	.CABLE,SPECIAL PURPO	1
8	XAOZZ	19207	8724316	.SHELL,ELECTRICAL CO CABLE PLUG	1
9	XAOZZ	19207	7358188	.BUSHING,RUBBER CABLE ASSEMBLY	1
10	XAOZZ	96906	MS39134-1	.SPRING, HOSE ANTI-KINK	1
11	XAOZZ	81349	M13486-1-5	.WIRE,ELECTRICAL	8
12	PAOZZ	96906	MS24629-47	SCREW,MACHINE, WIRING HARNESS	2
13	PAOZZ	96906	MS35335-32	WASHER,LOCK	2
14	PAOZZ	19207	8382973	STRAP,RETAINING CABLE ASSEMBLY	1
15	PAOZZ	96906	MS90727-2	SCREW,CAP,HEXAGON H CABLE CLIP	1
16	PFOZZ	96906	MS21333-43	CLAMP,LOOP	1
17	PAOZZ	96906	MS35338-44	WASHER,LOCK	1
18	PAOZZ	96906	MS51968-2	NUT, PLAIN, HEXAGON	1

END OF FIGURE

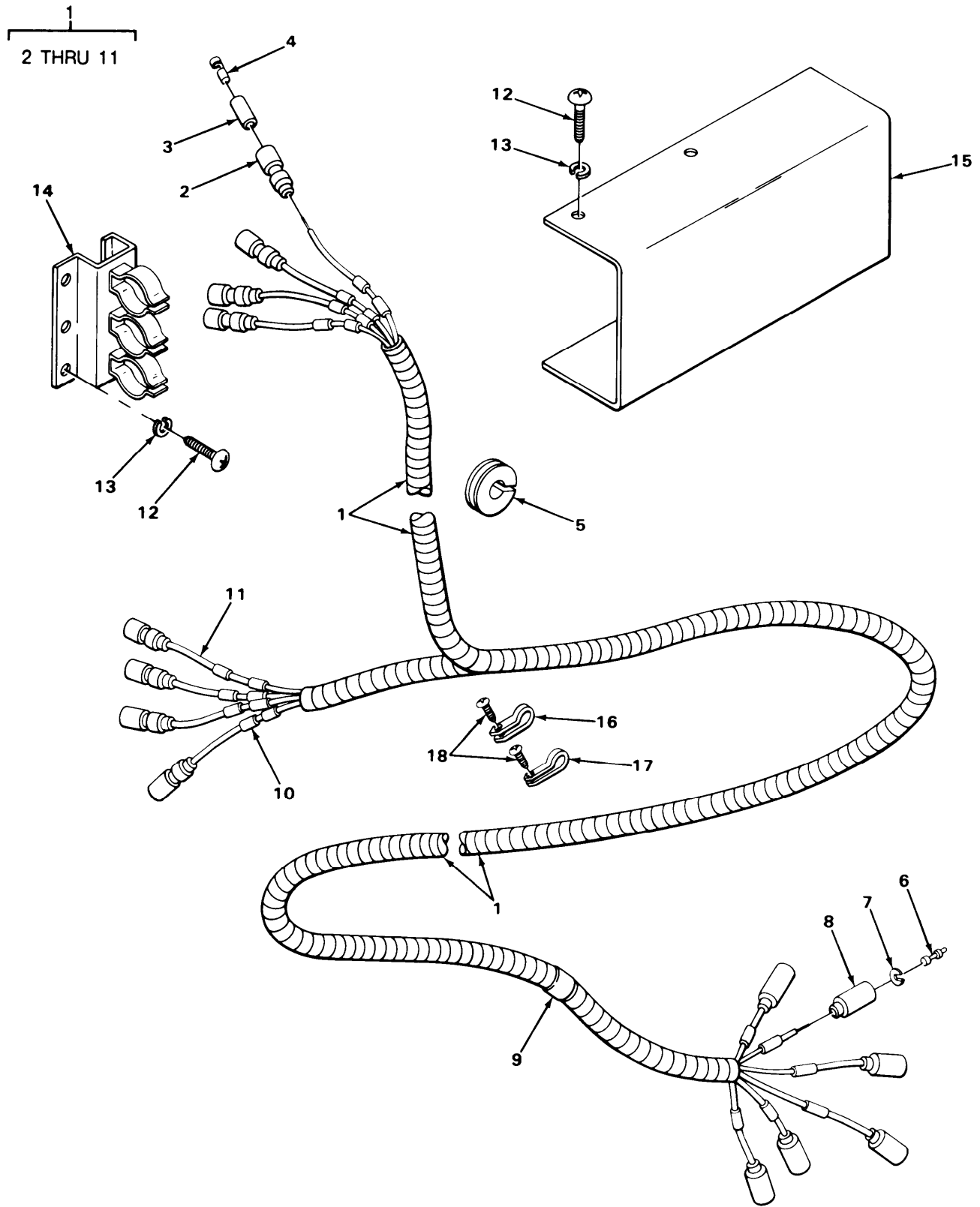

TA503156

FIGURE 3. WIRING HARNESS.

SECTION II		TM9-2330-251-14&P			
(1)	(2)	(3)	(4)	(5)	(6)
ITEM	SMR		PART		
NO	CODE	CAGEC	NUMBER	DESCRIPTION AND USABLE ON CODES (UOC)	QTY
				GROUP 0613 HULL OR CHASSIS WIRING HARNESS	
				FIG. 3 WIRING HARNESS	
1	PAOZZ	19207	10924552	WIRING HARNESS BRANCHED	1
2	XAOZZ	19207	8338566	.SHELL, ELECTRICAL WIRING HARNESS	8
3	XAOZZ	19207	8338562	.INSULATOR,BUSHING	8
4	XAOZZ	19207	8338564	.TERMINAL ASSEMBLY	8
5	XAOZZ	19207	7375064	.GROMMET RUBBER	5
6	XAOZZ	96906	MS27148-2	.CONTACT,ELECTRICAL	6
7	XAOZZ	19207	8338567	.WASHER, SLOTTED WIRING HARNESS	6
8	XAOZZ	19207	8338561	.SHELL,ELECTRICAL CO	6
9	XAOZZ	81349	M43436-1-3	.BAND,MARKER WIRING HARNESS	1
10	XAOZZ	96906	MS39020-1	.BAND,MARKER,BLANK	24
11	XAOZZ	81349	M13486-1-5	.WIRE, ELECTRICAL	8
12	PAOZZ	96906	MS24629-47	SCREW,TAPPING,THREA WIRING HARNESS COVER AND CLIP	8
13	PAOZZ	96906	MS35335-32	WASHER,LOCK WIRING HARNESS COVER AND CLIP	8
14	PAOZZ	19207	8722870	CLIP ASSEMBLY	2
15	PFOZZ	19207	10924576	COVER,JUNCTION BOX UOC:957	1
16	PAOZZ	19207	7979250	CLAMP,LOOP WIRING HARNESS	5
17	PFOZZ	96906	MS21333-4	CLAMP,LOOP	5
18	PAOZZ	96906	MS24629-48	SCREW,TAPPING,THREA	10

END OF FIGURE

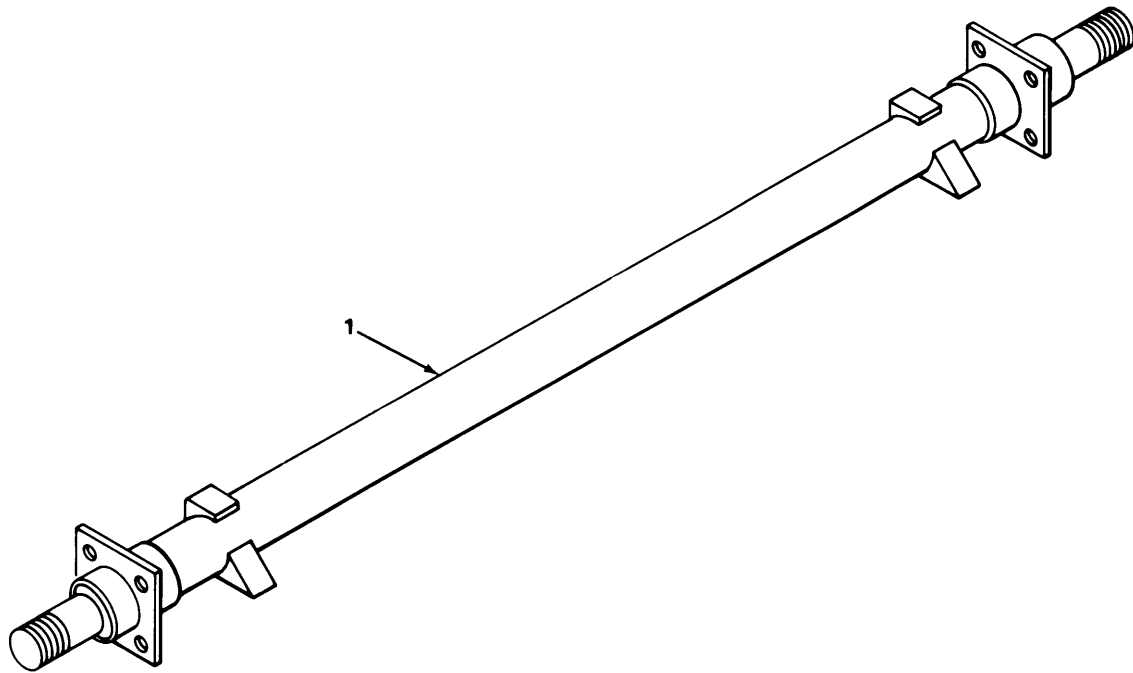

FIGURE 4. AXLE ASSEMBLY.

SECTION II		TM9-2330-251-14&P			
(1)	(2)	(3)	(4)	(5)	(6)
ITEM	SMR		PART		
NO	CODE	CAGEC	NUMBER	DESCRIPTION AND USABLE ON CODES (UOC)	QTY
				GROUP 11 REAR AXLE	
				GROUP 1100 REAR AXLE ASSEMBLY	
				FIG. 4 AXLE ASSEMBLY	
1	PBOZZ	19207	11625501	AXLE,VEHICULAR	1
				UOC:U69	
1	XBOZZ	19207	10924599	AXLE,VEHICULAR	1
				UOC:957	
				END OF FIGURE	

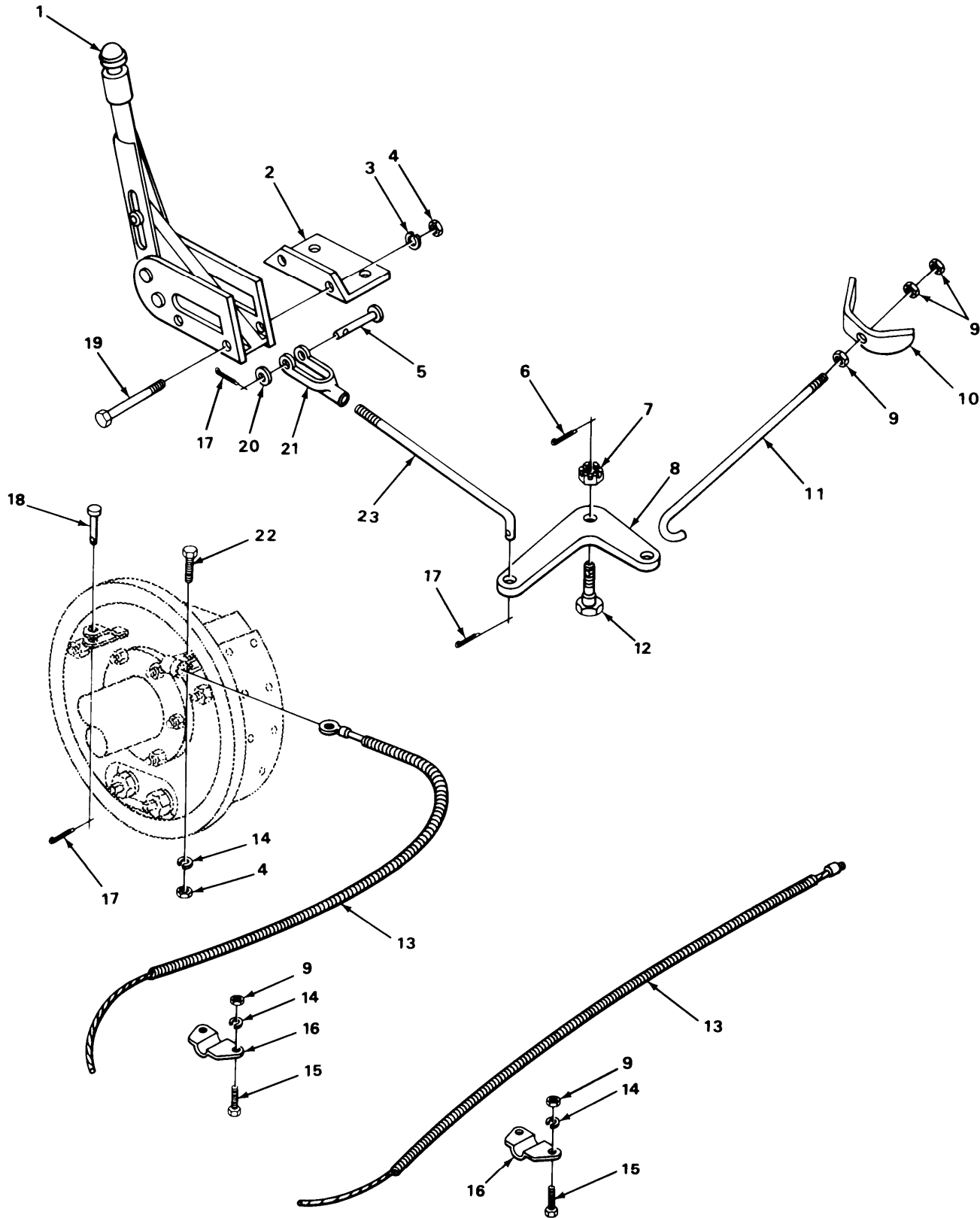
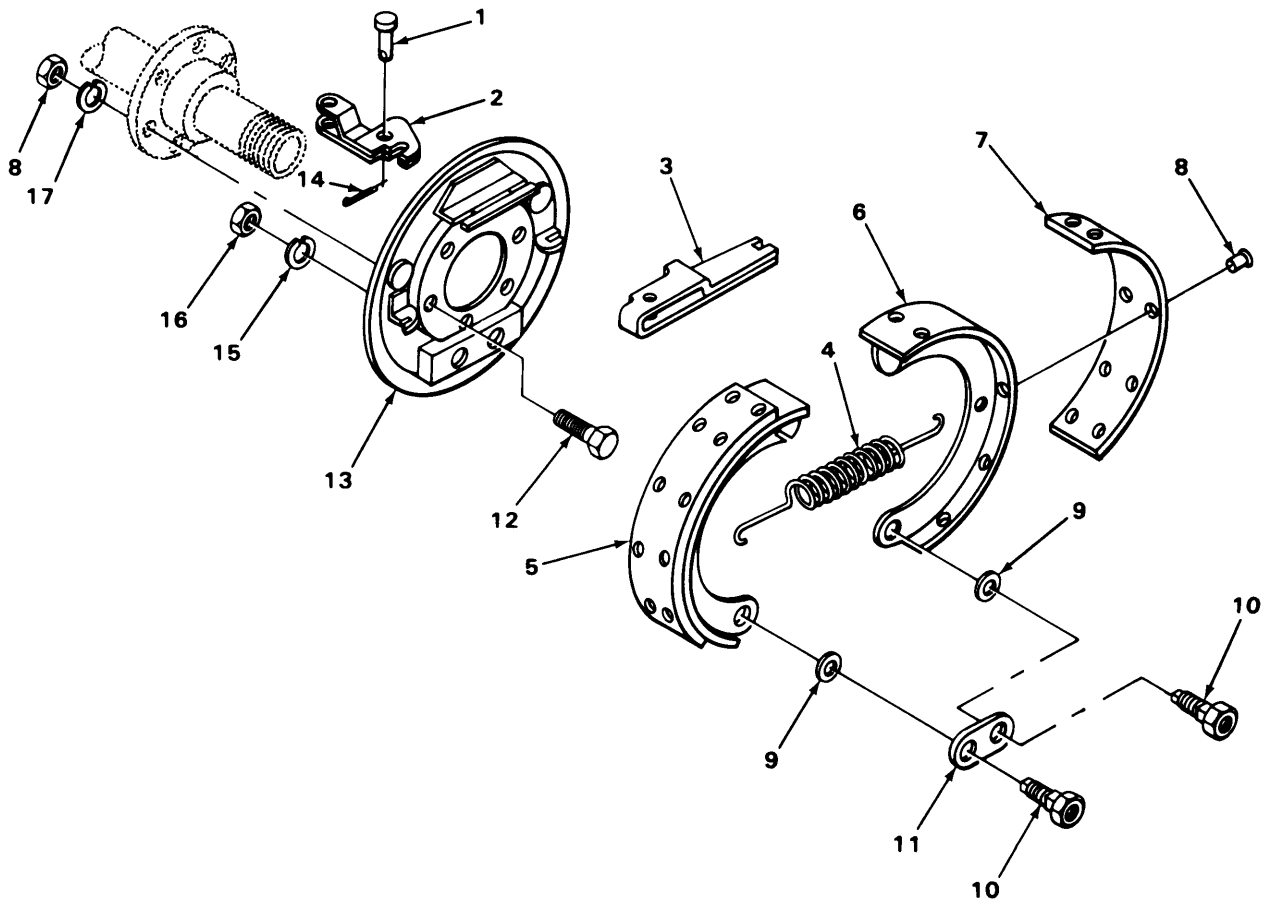

FIGURE 5. HANDBRAKE ASSEMBLY.

SECTION II				TM9-2330-251-14&P	
(1)	(2)	(3)	(4)	(5)	(6)
ITEM	SMR		PART		
NO	CODE	CAGEC	NUMBER	DESCRIPTION AND USABLE ON CODES (UOC)	QTY
GROUP 12 BRAKES					
GROUP 1201 HANDBRAKES					
FIG. 5 HANDBRAKE ASSEMBLY					
1	PAOZZ	19207	10920594	LEVER ASSEMBLY HANDBRAKE	1
2	PAOZZ	19207	10924596	BRACKET, ANGLE UOC:U69	1
3	PAOZZ	96906	MS35338-46	WASHER, LOCK	2
4	PAOZZ	96906	MS51968-8	NUT, PLAIN, HEXAGON	4
5	PAOZZ	23705	325118	PIN, STRAIGHT, HEADED CLEVIS TO LEVER	1
6	PAOZZ	96906	MS24665-283	COTTER PIN HANDBRAKE ASSEMBLY	1
7	PFOZZ	96906	MS35692-21	NUT, PLAIN, SLOTTED, H	1
8	PAOZZ	03677	73-1483	BELL CRANK HANDBRAKE ASSEMBLY	1
9	PAOZZ	96906	MS51968-5	NUT, PLAIN, HEXAGON	5
10	PAOZZ	19207	7328334	EQUALIZER HANDBRAKE ASSEMBLY	1
11	PAOZZ	19207	10924581	ROD, ADJUSTING, HANDBRAKE ASSEMBLY	1
12	PAOZZ	19207	7328333	BOLT, SHOULDER PIVOT	1
13	PAOZZ	19207	7328329	CABLE ASSEMBLY HAND WITH CONDUIT UOC:957	1
13	PAOZZ	19207	11625489	CABLE ASSEMBLY, BRAK PARKING BRAKE UOC:U69	1
14	PAOZZ	96906	MS35338-45	WASHER, LOCK CABLE CLIP	6
15	PAOZZ	96906	MS90727-32	BOLT, MACHINE	4
16	PAOZZ	19207	7328331	STRAP, RETAINING HANDBRAKE CABLE ASSEMBLY	2
17	PAOZZ	96906	MS24665-295	PIN, COTTER	4
18	PAOZZ	19207	7735847	PIN, STRAIGHT, HANDBRAKE ASSEMBLY	1
19	PAOZZ	96906	MS90727-66	SCREW, CAP, HEXAGON H	2
20	PAOZZ	96906	MS27183-5	WASHER, FLAT	1
21	XBOZZ	24076	22043	CLEVIS HANDBRAKE ASSEMBLY UOC:957	1
21	PADZZ	96906	MS35812-3	CLEVIS, ROD END UOC:U69	1
22	PAOZZ	96906	MS90726-36	SCREW	2
23	XBOZZ	19207	10942507	CONNECTING LINK RIG	1

END OF FIGURE

5
6 THRU 8



TA503159

FIGURE 6. BRAKESHOE AND SUPPORT ASSEMBLY, M416.

SECTION II		TM9-2330-251-14&P			
(1)	(2)	(3)	(4)	(5)	(6)
ITEM	SMR		PART		
NO	CODE	CAGEC	NUMBER	DESCRIPTION AND USABLE ON CODES (UOC)	QTY
GROUP 1202 SERVICE BRAKES					
FIG. 6 BRAKESHOE AND SUPPORT ASSEMBLY, M416					
1	PAOZZ	19207	7971302	PIN, STRAIGHT, HEADED UOC:957	2
2	PAOZZ	70142	47179-13	PAWL BRAKE SUPPORT UOC:957	2
3	PAOZZ	19207	7324344	STRUT, BRAKE SHOE BRAKE ASSEMBLY UOC:957	2
4	PAOZZ	12603	854584	SPRING, HELICAL, EXTE BRAKE SHOE RETURN UOC:957	2
5	PAOFF	19204	12010439	BRAKE SHOE UOC:957	4
6	PAOZZ	19207	8678964	.BRAKE SHOE UOC:957	4
7	PAFZZ	19207	8678967	.LINING, FRICTION LEFT AND RIGHT FRONT SHOE UOC:957	1
7	PAFZZ	19207	8678969	.LINING, FRICTION LEFT AND RIGHT REAR SHOE UOC:957	1
8	PAFZZ	19207	8701138	.RIVET, TUBULAR UOC:957	10
9	PAOZZ	19207	5304063	CAM, ANCHOR PIN, BRAKE SHOE UOC:957	4
10	PAOZZ	33116	22377	PIN, CAM ANCHOR BRAKE SHOE UOC:957	4
11	PAOZZ	19207	5304070	PLATE, PIN BRAKE ANC BRAKE SHOE ASSEMBLY UOC:957	2
12	PAOZZ	96906	MS90727-60	SCREW, CAP, HEXAGON H UOC:957	12
13	PAOZZ	19207	7377747	PLATE ASY BACKING LEFT UOC:957	2
13	PAOZZ	19207	7377748	PLATE, BACKING, BRAKE RIGHT UOC:957	1
14	PAOZZ	96906	MS24665-134	PIN, COTTER UOC:957	2
15	PAOZZ	96906	MS35338-48	WASHER, LOCK UOC:957	4
16	PAOZZ	96906	MS51968-14	NUT, PLAIN, HEXAGON UOC:957	4
17	PFOZZ	96906	MS35338-46	WASHER, LOCK UOC:957	12
18	PAOZZ	96906	MS51968-8	NUT, PLAIN, HEXAGON BRAKE ASSEMBLY UOC:957	12

END OF FIGURE

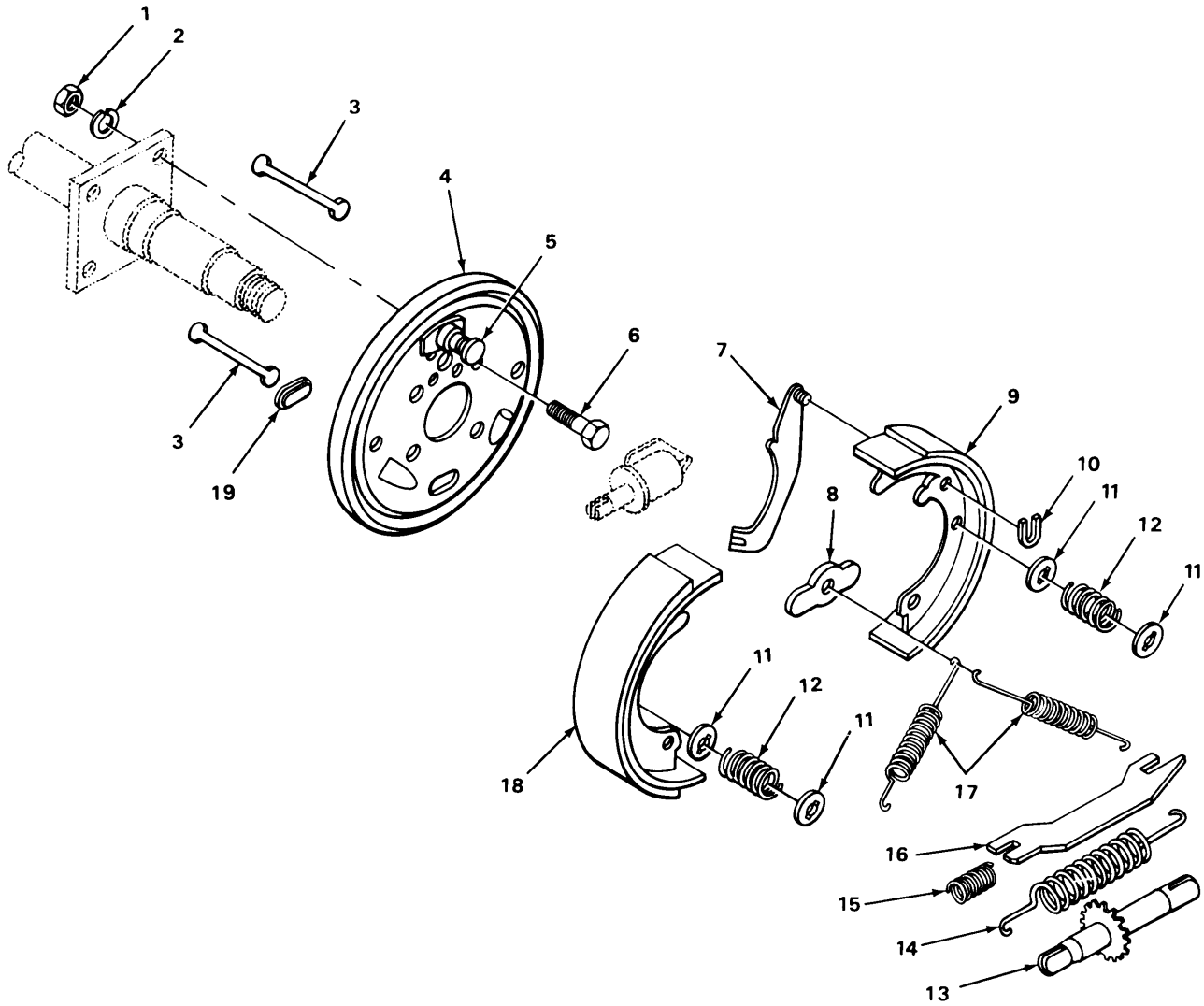

TA503160

FIGURE 7. BRAKESHOE AND SUPPORT ASSEMBLY, M416A1.

SECTION II		TM9-2330-251-14&P			
(1)	(2)	(3)	(4)	(5)	(6)
ITEM	SMR		PART		
NO	CODE	CAGEC	NUMBER	DESCRIPTION AND USABLE ON CODES (UOC)	QTY
GROUP 1202 SERVICE BRAKES					
FIG. 7 BRAKESHOE AND SUPPORT ASSEMBLY, M416A1					
1	PAOZZ	96906	MS51968-11	NUT,PLAIN,HEXAGON BRAKE ASSEMBLY UOC:U69	8
2	PAOZZ	96906	MS35338-47	WASHER,LOCK BRAKE ASSEMBLY UOC:U69	8
3	PAOZZ	94189	10959	PIN,STRAIGHT,HEADED HOLD DOWN UOC:U69	4
4	PFOZZ	94189	24636	PLATE,BACKING,BRAKE ASSEMBLY UOC:U69	2
5	PAOZZ	94189	14886	PIN, ANCHOR UOC:U69	2
6	PAOZZ	96906	MS90727-85	SCREW,CAP,HEXAGON H UOC:U69	8
7	PAOZZ	94189	16092	LEVER ASSEMBLY,PARK RIGHT PARKING BRAKE UOC:U69	1
7	PAOZZ	14894	308430-L	LEVER,REMOTE CONTRO LEFT PARKING BRAKE UOC:U69	1
8	PAOZZ	94189	10961	PLATE,SHOE GUIDE UOC:U69	2
9	PAOZZ	94189	10953	BRAKE SHOE SET,INTE BRAKE,REAR UOC:U69	2
10	PAOZZ	94189	9795	RETAINER, PARKING BRAKE UOC:U69	2
11	XDOZZ	94189	9789	SEAT,HELICAL COMPRE UOC:U69	8
12	PAOZZ	94189	10960	SPRING UOC:U69	4
13	PAOZZ	94189	10954	ADJUSTER,SLACK,BRAK ADJUSTING UOC:U69	2
14	PAOZZ	19207	5303469	SPRING,HELICAL,EXTE ADJUSTING SCREW UOC:U69	2
15	PAOZZ	06853	39244	SPRING,HELICAL,COMP PARKING BRAKE UOC:U69	2
16	PAOZZ	94189	16756	STRUT,BRAKE SHOE PARKING BRAKE UOC: U69	2
17	PAOZZ	94189	10958	SPRING, BRAKE SHOE UOC:U69	2
18	PAOZZ	94189	10952	BRAKE SHOE BRAKE,FRONT UOC:U69	2
19	PAOZZ	94189	9254	COVER UOC:469	2

END OF FIGURE

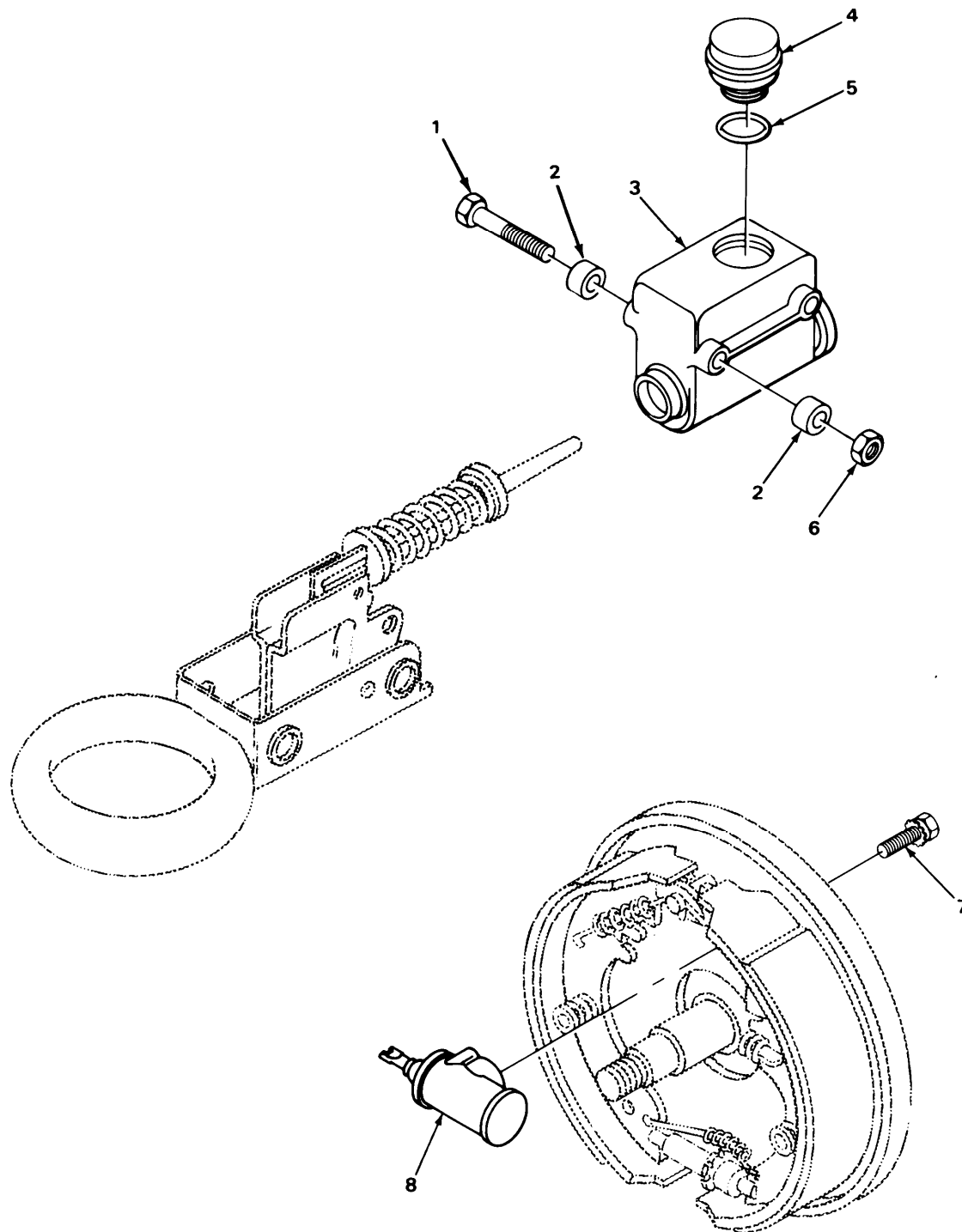
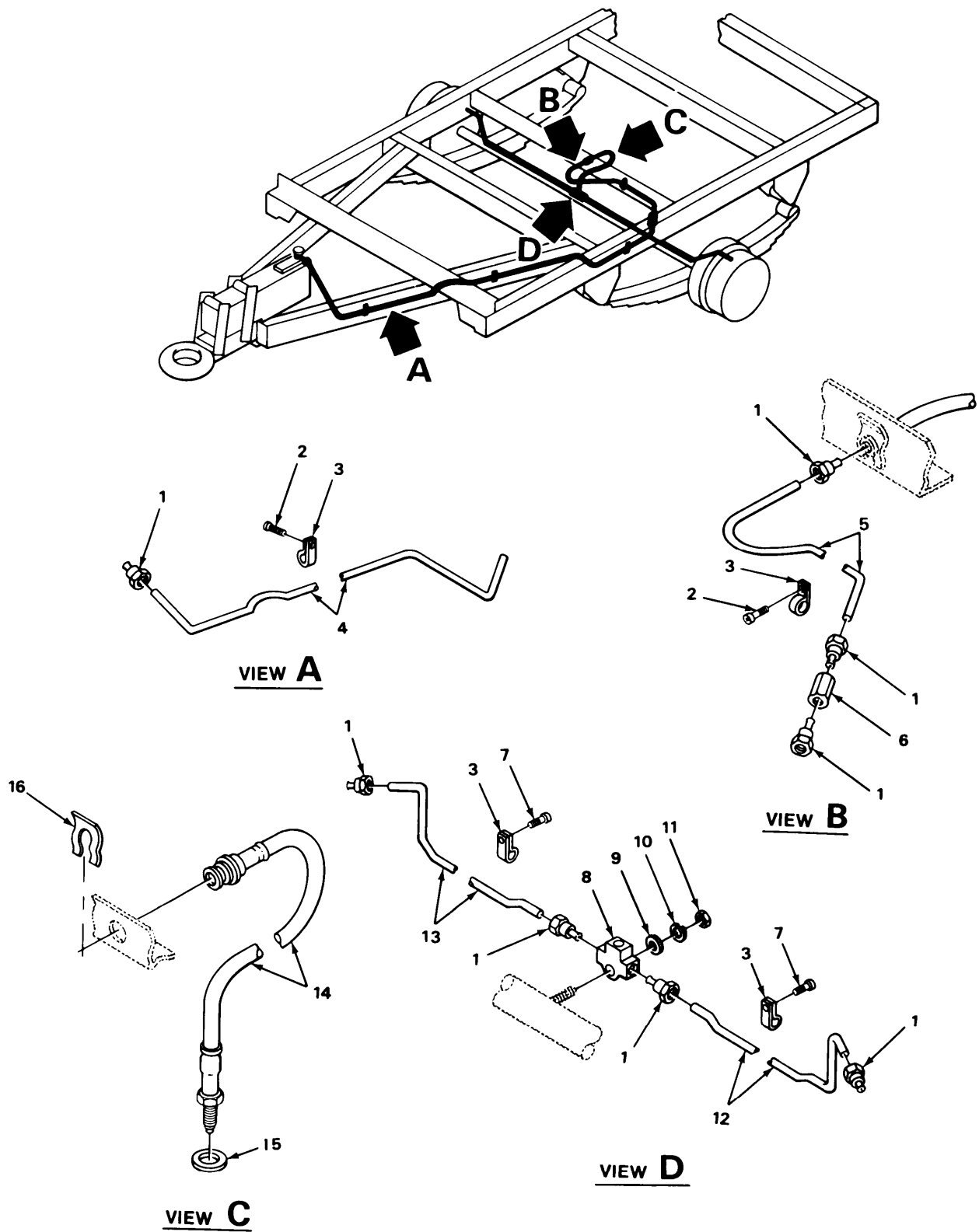

FIGURE 8. MASTER CYLINDER AND WHEEL CYLINDER ASSEMBLY.

SECTION II				TM9-2330-251-14&P	
(1)	(2)	(3)	(4)	(5)	(6)
ITEM NO	SMR CODE	CAGEC	PART NUMBER	DESCRIPTION AND USABLE ON CODES (UOC)	QTY
GROUP 1204 HYDRAULIC BRAKE SYSTEM					
FIG. 8 MASTER CYLINDER AND WHEEL CYLINDER ASSEMBLY					
1	PAOZZ	96906	MS90727-72	SCREW,CAP,HEXAGON H UOC:U69	2
2	PAOZZ	93072	1841	SPACER, ACTUATOR UOC:U69	4
3	PAOZZ	93072	10614	CYLINDER ASSEMBLY,H WITH FITTINGS UOC:U69	1
4	PAOZZ	19207	12331725-2	ADAPTER,STRAIGHT,TU CAP FILLER UOC:U69	1
5	PAOZZ	80205	NAS1611-128	PACKING,PREFORMED MASTER CYLINDER FILLER CAP UOC:U69	1
6	PAOZZ	96906	MS51922-21	NUT,SELF LOCKING UOC:U69	2
7	PAOZZ	94189	9778	SCREW,ASSEMBLED WAS UOC:U69	4
8	PAOZZ	94189	9777	CYLINDER ASSEMBLY,H LEFT WHEEL UOC:U69	1
8	PAOZZ	94189	9776	CYLINDER ASSEMBLY,H RIGHT WHEEL UOC:U69	1
END OF FIGURE					



TA503162

FIGURE 9. HYDRAULIC BRAKE LINES, HOSES, AND FITTINGS.

SECTION II		TM9-2330-251-14&P				
(1)	(2)	(3)	(4)	(5)	(6)	
ITEM NO	SMR CODE	CAGEC	PART NUMBER	DESCRIPTION AND USABLE ON CODES (UOC)	QTY	
GROUP 1204 HYDRAULIC BRAKE SYSTEM						
FIG. 9 HYDRAULIC BRAKE LINES, HOSES, AND FITTINGS						
1	PAOZZ	12204	142431	INVERTED NUT, TUBE C UOC:U69	8	
2	PAOZZ	96906	MS24629-45	SCREW, TAPPING UOC:U69	4	
3	PAOZZ	96906	MS21333-2	CLAMP, LOOP UOC:U69	6	
4	MOOZZ	19207	11625494	TUBE ASSEMBLY, METAL MAKE FROM TUBE P/N 10943231 UOC:U69	1	
5	MOOZZ	19207	11625493	TUBE ASSEMBLY, METAL MAKE FROM TUBE P/N 10943231 UOC:U69	1	
6	PAOZZ	96906	MS51877-3	COUPLING, TUBE UOC:U69	1	
7	PAOZZ	96906	MS35206-261	SCREW, MACHINE UOC:U69	2	
8	PAOZZ	79470	7805	TEE, TUBE FITTING UOC:U69	1	
9	PAOZZ	96906	MS27183-10	WASHER, FLAT UOC:U69	1	
10	PAOZZ	96906	MS35338-44	WASHER, LOCK UOC:U69	1	
11	PAOZZ	96906	MS51967-2	NUT, PLAIN, HEXAGON UOC:U69	1	
12	MOOZZ	19207	11625492-2	TUBE ASSEMBLY, METAL MAKE FROM TUBE P/N 10943231 UOC:U69	1	
13	MOOZZ	19207	11625492-1	TUBE ASSEMBLY METAL MAKE FROM TUBE P/N 10943231 UOC:U69	1	
14	PAOZZ	19207	11625495	HOSE ASSEMBLY NONMETALLIC UOC:U69	1	
15	PAOZZ	19207	11625497	GASKET, COPPER, BENDIX UOC:U69	1	
16	PAOZZ	19207	11625505	CLIP, SPRING TENSION UOC:U69	1	

END OF FIGURE

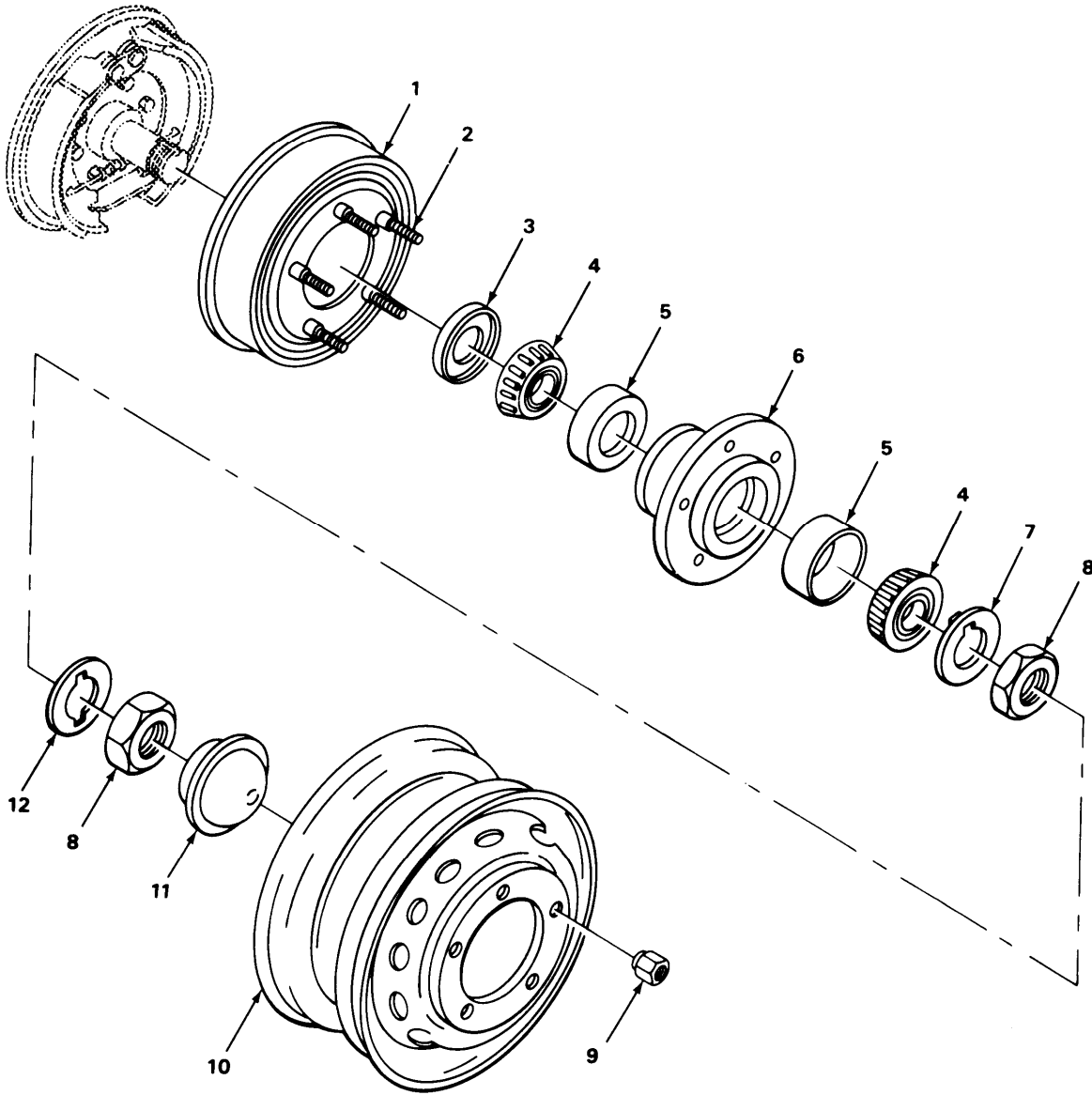

TA503163

FIGURE 10. HUB AND DRUM ASSEMBLY, M416.

SECTION II				TM9-2330-251-14&P	
(1)	(2)	(3)	(4)	(5)	(6)
ITEM	SMR		PART		
NO	CODE	CAGEC	NUMBER	DESCRIPTION AND USABLE ON CODES (UOC)	QTY
				GROUP 13 WHEELS AND TRACKS	
				GROUP 1311 WHEEL ASSEMBLY	
				FIG. 10 HUB AND DRUM ASSEMBLY, M416	
1	PAOFF	71770	FMC8372	BRAKE DRUM WHEEL ASSEMBLY UOC:957	2
2	PAOZZ	33116	X43436	BOLT,RIBBED SHOULDE UOC:957	10
3	PAOZZ	80201	516992	SEAL,PLAIN ENCASED OIL UOC:957	2
4	PAOZZ	19207	8762093	BEARING ROLLER TAPERED UOC:957	4
5	PAOZZ	19207	7536132	CUP, TAPEREC ROLLER BEARING UOC:957	4
6	PAOZZ	19207	10924603	HUB,BODY UOC:957	2
7	PAOZZ	19207	7696521	WASHER,KEY HUB OUTER BEARING LOCK UOC:957	2
8	PAOZZ	21450	7371106	NUT,PLAIN,HEXAGON HUB OUTER BEARING ADJUSTING UOC:957	4
9	PFOZZ	96906	MS53069-1	NUT,CAP,DUAL WHEEL HUB STUD UOC:957	10
10	PAOZZ	19207	12301157	WHEEL,PNEUMATIC TIR UOC:957	2
11	XDOZZ	33116	X-43438	CAP DUST	2
12	PAOZZ	19207	7696520	WASHER,KEY HUB OUTER BEARING RETAINER UOC:957	2

END OF FIGURE

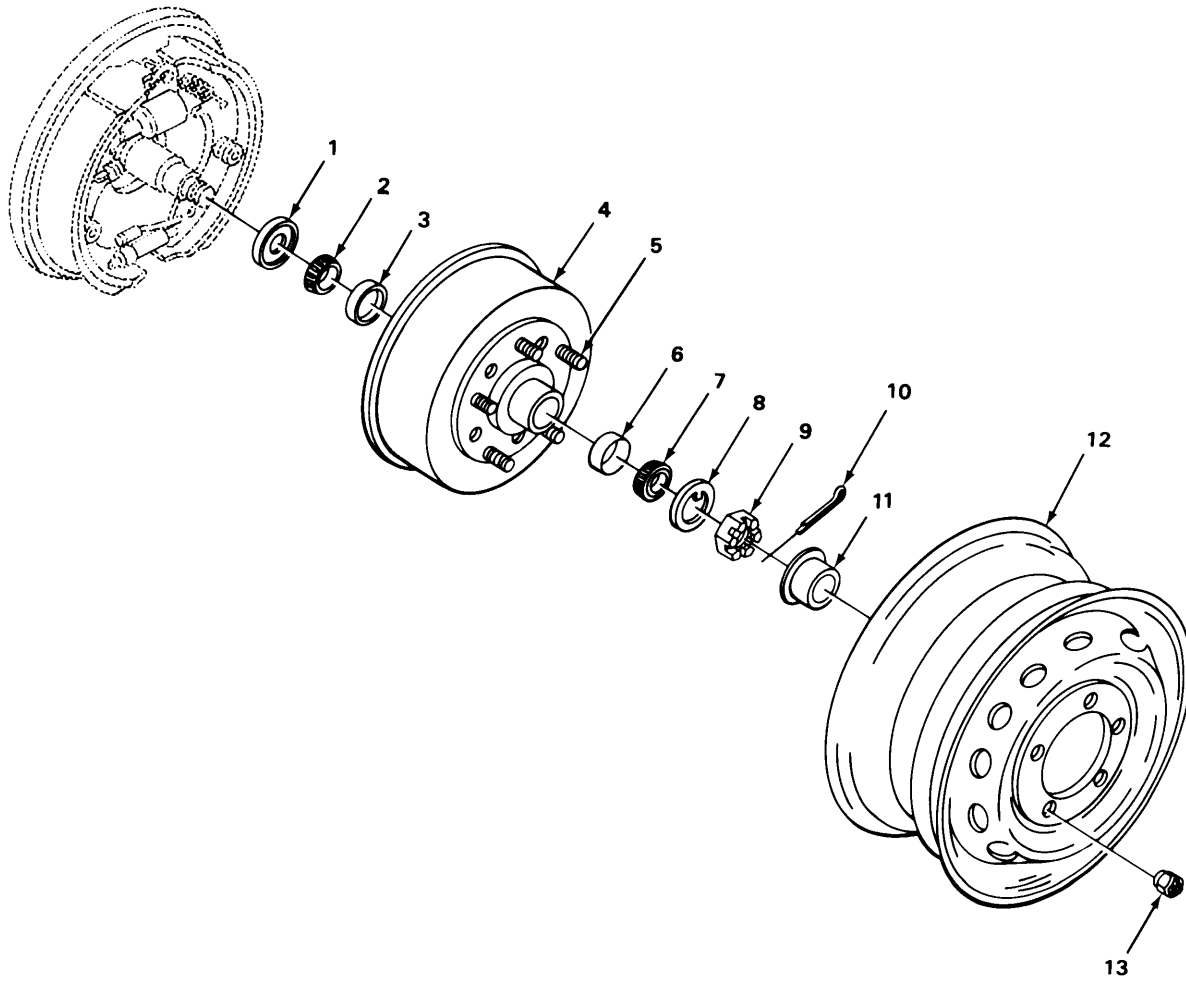

TA503164

FIGURE 11. HUB AND DRUM ASSEMBLY, M416A1.

SECTION II				TM9-2330-251-14&P	
(1)	(2)	(3)	(4)	(5)	(6)
ITEM	SMR		PART		
NO	CODE	CAGEC	NUMBER	DESCRIPTION AND USABLE ON CODES (UOC)	QTY
				GROUP 1311 WHEEL ASSEMBLY	
				FIG. 11 HUB AND DRUM ASSEMBLY, M416A1	
1	PAOZZ	94189	15529	SEAL,PLAIN,ENCASED OIL UOC:U69	2
2	PAOZZ	60038	L68149	CONE AND ROLLERS,TA UOC:U69	2
3	PAOZZ	60038	L68111	CUP,TAPERED ROLLER UOC:U69	2
4	PAOFF	94189	18147	BRAKE DRUM UOC:U69	2
5	PAOZZ	94189	14771	BOLT,RIBBED SHOULDE UOC:U69	10
6	PAOZZ	60038	L44649	CONE AND ROLLERS,TA UOC:U69	2
7	PAOZZ	60038	L44610	CUP,TAPERED ROLLER BEARING UOC:U69	2
8	PAOZZ	96906	MS27183-23	WASHER UOC:U69	2
9	PAOZZ	96906	MS35692-62	NUT,PLAIN,SLOTTED UOC:U69	2
10	PAOZZ	96906	MS24665-355	PIN,COTTER UOC:U69	2
11	PAOZZ	94189	14286	CAP,DUST UOC:U69	2
12	PAOZZ	19207	10921860	WHEEL,PNUEMATIC TRE TRAILER UOC:U69	2
13	PAOZZ	19207	11630595	NUT,PLAIN AXLE UOC:U69	10

END OF FIGURE

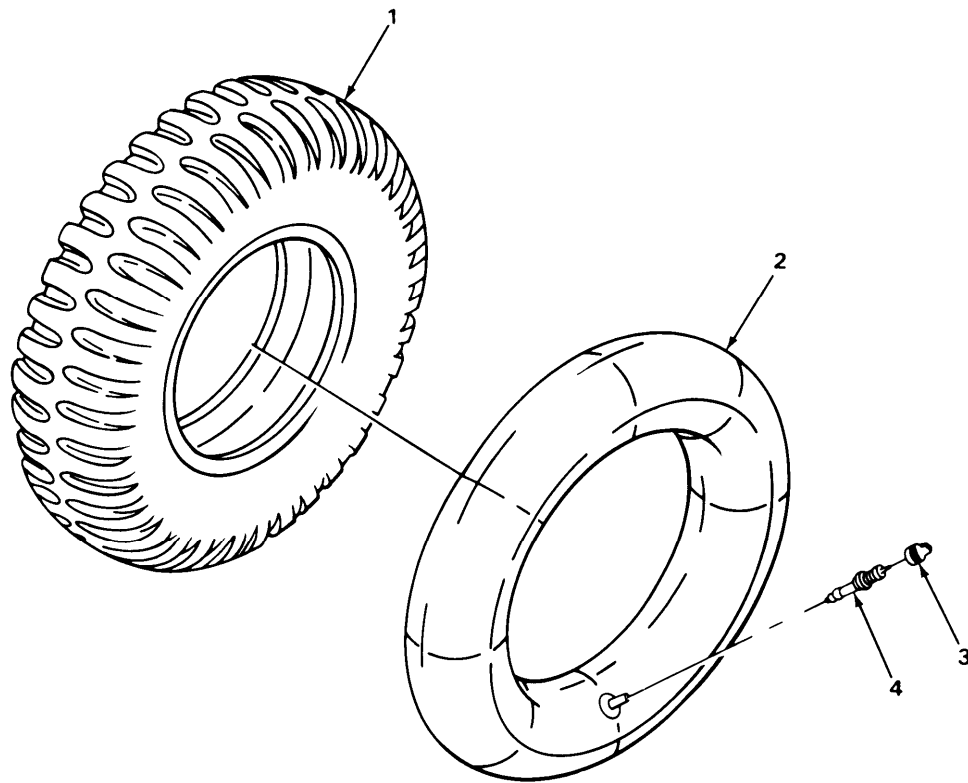

FIGURE 12. TIRES AND TUBES.

SECTION II				TM9-2330-251-14&P		
(1)	(2)	(3)	(4)	(5)	(6)	
ITEM NO	SMR CODE	CAGEC	PART NUMBER	DESCRIPTION AND USABLE ON CODES (UOC)	QTY	
GROUP 1313 TIRES AND TUBES						
FIG. 12 TIRES AND TUBES						
1	PFOFF	19207	7342996	TIRE,PNEUMATIC	2	
2	PAOOO	81348	ZZ-I-550/GP2/6.0 0-16/TR15/OFFCTR	INNER TUBE,PNEUMATI	2	
3	PAOZZ	51665	US48	CAP,PNEUMATIC VALVE	2	PNEUMATIC TIRE
4	PAOZZ	17875	100AA	VALVE CORE	2	
END OF FIGURE						

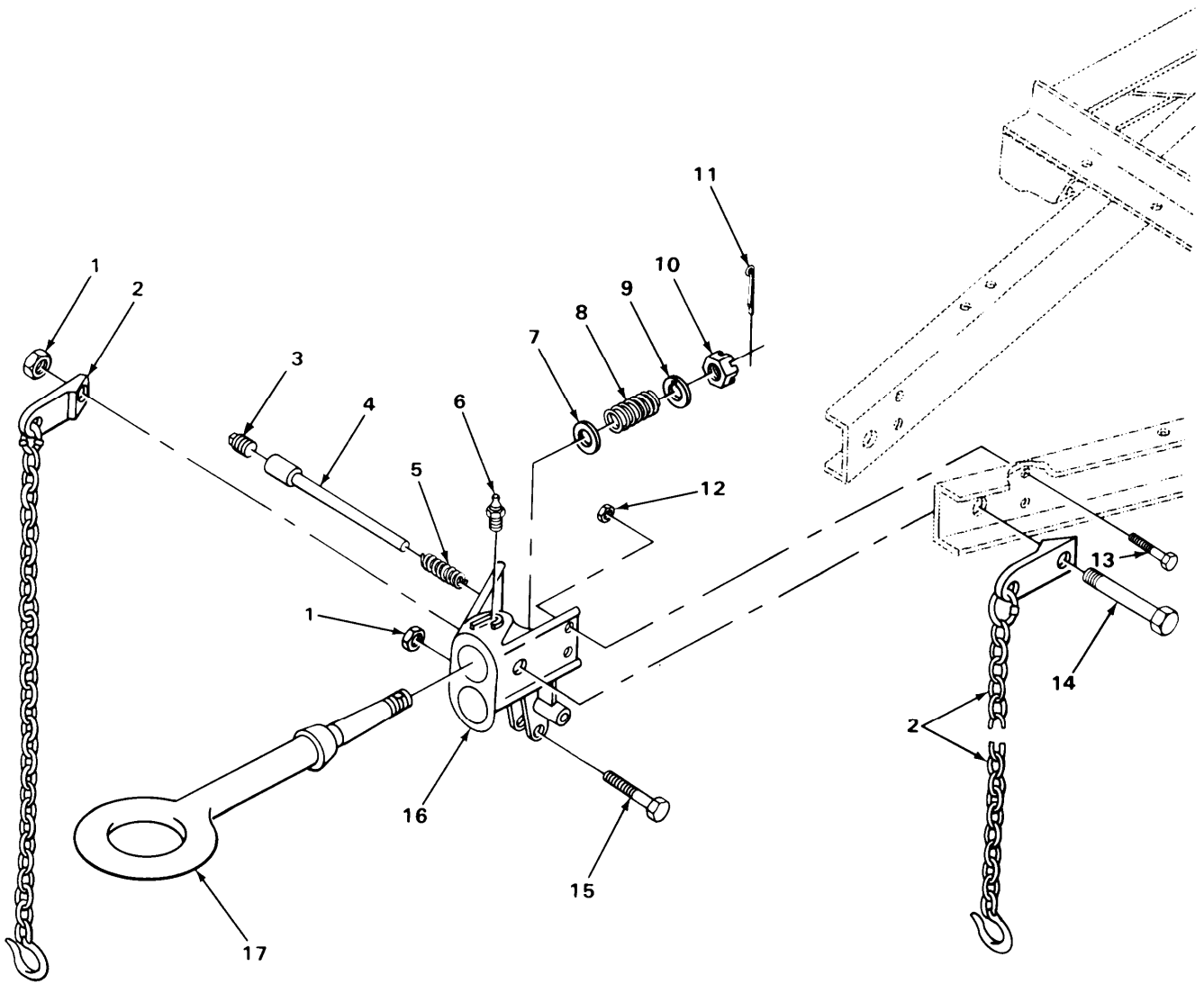
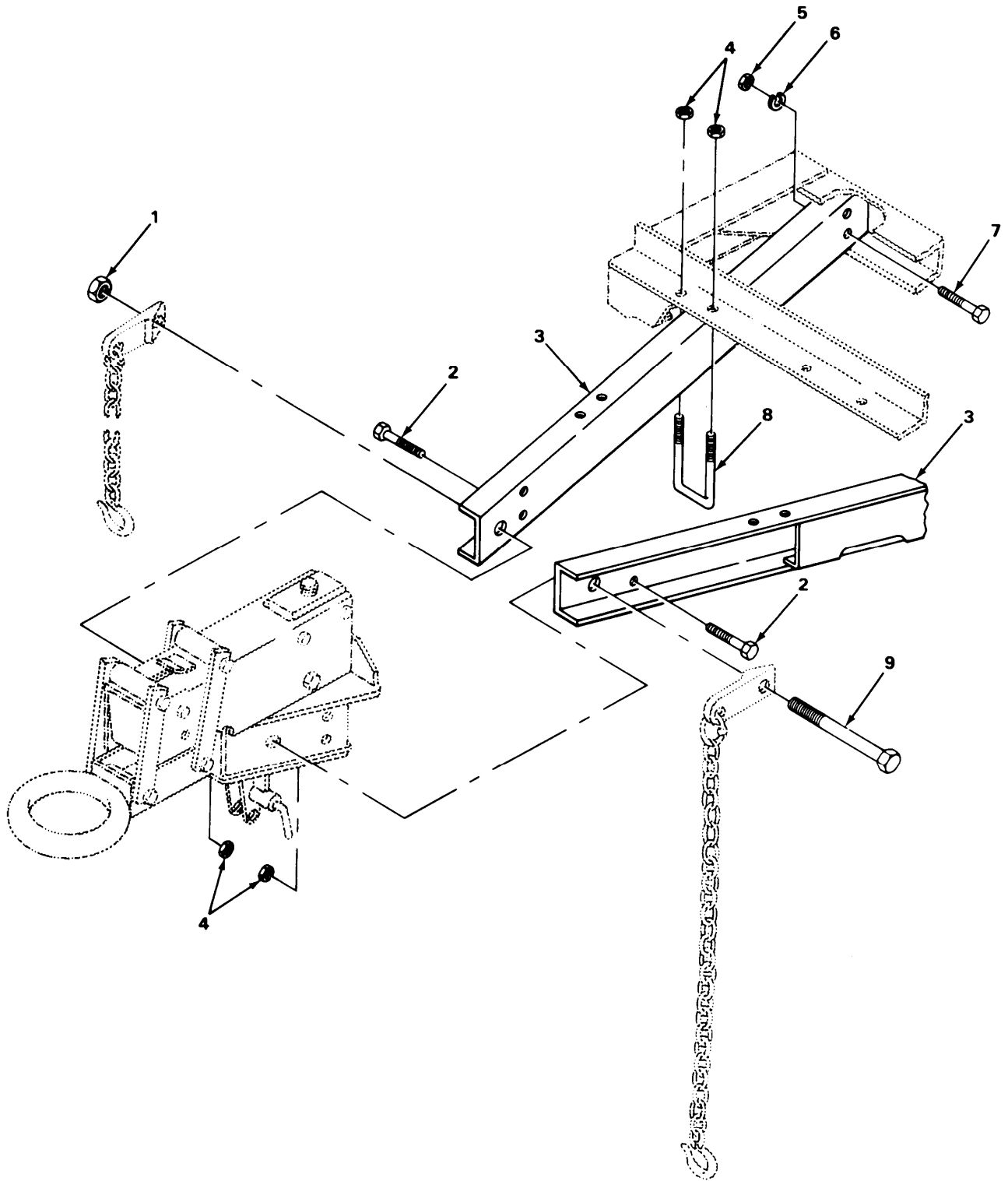

FIGURE 13. DRAWBAR COUPLER.

SECTION II		TM9-2330-251-14&P			
(1)	(2)	(3)	(4)	(5)	(6)
ITEM NO	SMR CODE	CAGEC	PART NUMBER	DESCRIPTION AND USABLE ON CODES (UOC)	QTY
GROUP 15 FRAME AND TOWING ATTACHMENTS					
GROUP 1503 PINTILES AND TOWING ATTACHMENTS					
FIG. 13 DRAWBAR COUPLER					
1	PAOZZ	23040	360403S7A1	NUT, SELF-LOCKING, HEXAGON UOC:957	2
2	PAOZZ	71770	FMC 8317	CHAIN ASSEMBLY, SING	2
3	PAOZZ	02951	MS49005-8	PLUG, PIPE	1
4	PAOZZ	19207	7001417	PIN, SHOULDER, HEADLESS LOCKPIN	1
5	PAOZZ	94833	73-1438	SPRING, HELICAL, COMP LOCK PLUNGER	1
6	PAOZZ	96906	MS15003-1	FITTING, LUBRICATION UOC:957	2
7	PAOZZ	19207	7328312	WASHER, FLAT DRAWBAR UOC:957	1
8	PAOZZ	75828	EL53241-1	SPRING, HELICAL, COMP DRAWBAR UOC:957	1
9	PAOZZ	19207	7328314	WASHER, KEY DRAWBAR UOC:957	1
10	PFOZZ	19207	MS35692-1426	NUT, PLAIN, SLOTTED, H DRAWBAR ATTACHING UOC:957	1
11	PAOZZ	96906	MS20665-425	PIN, COTTER UOC:957	1
12	PAOZZ	96906	MS20365-820C	NUT, SELF-LOCKING, HEXAGON UOC:957	4
13	PAOZZ	96906	MS90727-85	SCREW, CAP, HEXAGON H UOC:957	4
14	XBOZZ	19207	595444	SCREW UOC:957	1
15	XDOZZ	19207	428829	SCREW	1
16	PAOZZ	19207	10924577	BRACKET DRAWBAR UOC:957	1
17	PAOZZ	19207	7328311	COUPLER, DRAWBAR UOC:957	1

END OF FIGURE



TA503167

FIGURE 14. ACTUATOR, DRAWBARS, AND ATTACHING PARTS.

SECTION II		TM9-2330-251-14&P			
(1)	(2)	(3)	(4)	(5)	(6)
ITEM NO	SMR CODE	CAGEC	PART NUMBER	DESCRIPTION AND USABLE ON CODES (UOC)	QTY
				GROUP 1503 PINTLES AND TOWING ATTACHMENTS	
				FIG. 14 ACTUATOR, DRAWBARS, AND ATTACHING PARTS	
1	PAOZZ	96906	MS51922-61	NUT, SELF-LOCKING, HE UOC:U69	1
2	PAOZZ	96906	MS90727-85	SCREW, CAP, HEXAGON H UOC:U69	4
3	XDOZZ	19207	10924587-2	CHANNEL RIGHT	1
3	XDOZZ	19207	10924587-1	FRAME SECTION, STRUC LEFT	1
4	PAOZZ	96906	MS51922-29	NUT, SELF-LOCKING, HE	8
5	PAOZZ	96906	MS51968-14	NUT, PLAIN, HEXAGON	4
6	PAOZZ	96906	MS35338-48	WASHER, LOCK	4
7	PAOZZ	96906	MS90726-109	SCREW, CAP, HEXAGON H	4
8	XBOZZ	19207	10924595	U-BOLT	2
9	PAOZZ	96906	MS90727-200	SCREW, CAP, HEXAGON H UOC:U69	1
				END OF FIGURE	

1
2 THRU 25

3
4 THRU 25

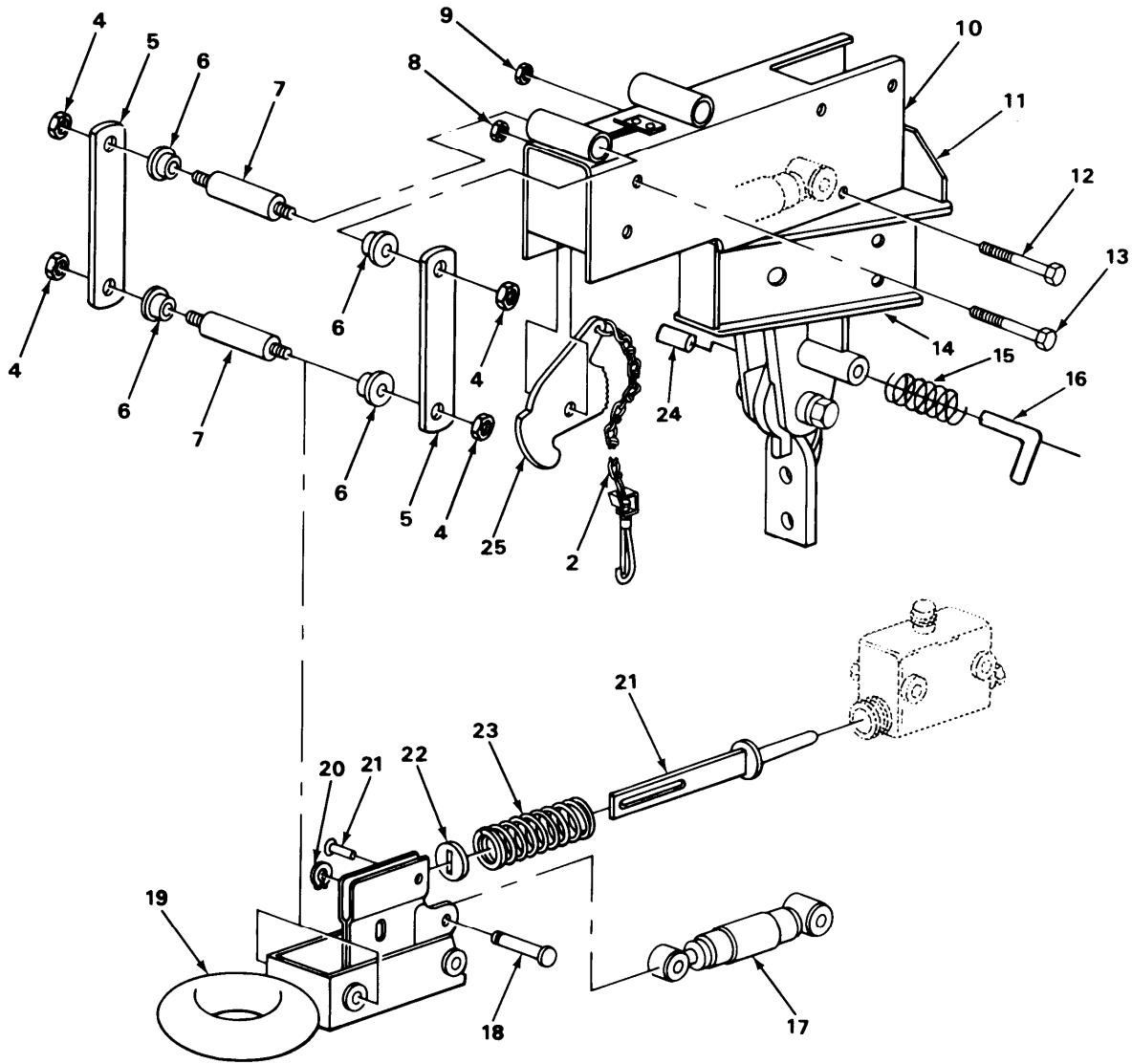

TA503168

FIGURE 15. ACTUATOR ASSEMBLY.

SECTION II				TM9-2330-251-14&P	
(1)	(2)	(3)	(4)	(5)	(6)
ITEM	SMR		PART		
NO	CODE	CAGEC	NUMBER	DESCRIPTION AND USABLE ON CODES (UOC)	QTY
				GROUP 1503 PINTLES AND TOWING ATTACHMENTS	
				FIG. 15 ACTUATOR ASSEMBLY	
1	PAOOO	19207	11625487	DRAWBAR,POLE TRAILER UOC:U69	1
2	PAOZZ	19207	12296386	.CHAIN ASSEMBLY,SING BREAKAWAY W/ HOOKS UOC:U69	1
3	PBOOO	19207	11625498	.ACTUATOR,BRAKE UOC:U69	1
4	PAOZZ	96906	MS21044N8	.NUT,SELF-LOCKING,HE UOC:U69	8
5	PAOZZ	93072	1808-1	.CONNECTING LINK ACTUATOR UOC:U69	4
6	PAOZZ	93072	1745	.BEARING,SLEEVE NYLON UOC:U69	8
7	PAOZZ	93072	1829	.SHAFT,CHAIN UOC:U69	4
8	PAOZZ	96906	MS51922-21	.NUT,SELF-LOCKING,HE UOC:U69	1
9	PAOZZ	96906	MS51922-29	.NUT,SELF-LOCKING UOC:U69	1
10	PFOZZ	93072	10603	.CHANNEL ASSEMBLY UOC:U69	1
11	XDOZZ	19207	11625500	.PLATE UOC:U69	1
12	PAOZZ	96906	MS90727-97	.SCREW,CAP,HEXAGON H UOC:U69	1
13	PAOZZ	96906	MS90727-72	.SCREW,CAP,HEXAGON H UOC:U69	1
14	PAOZZ	19207	11625499	.BRACKET,ANGLE UOC:U69	1
15	PAOZZ	19207	7328310	.SPRING UOC:U69	1
16	PAOZZ	19207	7001417	.PIN,SHOULDER HEADLESS LOCKPIN UOC:U69	1
17	PAOZZ	93072	1844-2	.SHOCK ABSORBER ACTUATOR UOC:U69	1
18	XDOZZ	93072	1855	.PIN UOC:U69	1
19	PAOZZ	93072	10632	.COUPLER,DRAWBAR,RIN BRAKE ACTUATOR ASSEMBLY UOC:U69	1
20	XDOZZ	93072	1756	.SNAP RING UOC:U69	1
21	PAOZZ	93072	10607	.PUSH ROD ASSEMBLY ACTUATOR UOC:U69	1
22	PAOZZ	93072	1840	.WASHER,PUSH ROD UOC:U69	1
23	PAOZZ	93072	1828	.SPRING,PUSH ROD	1

SECTION II				TM9-2330-251-14&P	
(1)	(2)	(3)	(4)	(5)	(6)
ITEM	SMR		PART		
NO	CODE	CAGEC	NUMBER	DESCRIPTION AND USABLE ON CODES (UOC)	QTY
24	PAOZZ	02951	MS49005-8	UOC:U69 ..PLUG, PIPE	1
25	PAOZZ	93072	1804	UOC:U69 ..LEVER, BREAKAWAY UOC:U69	1

END OF FIGURE

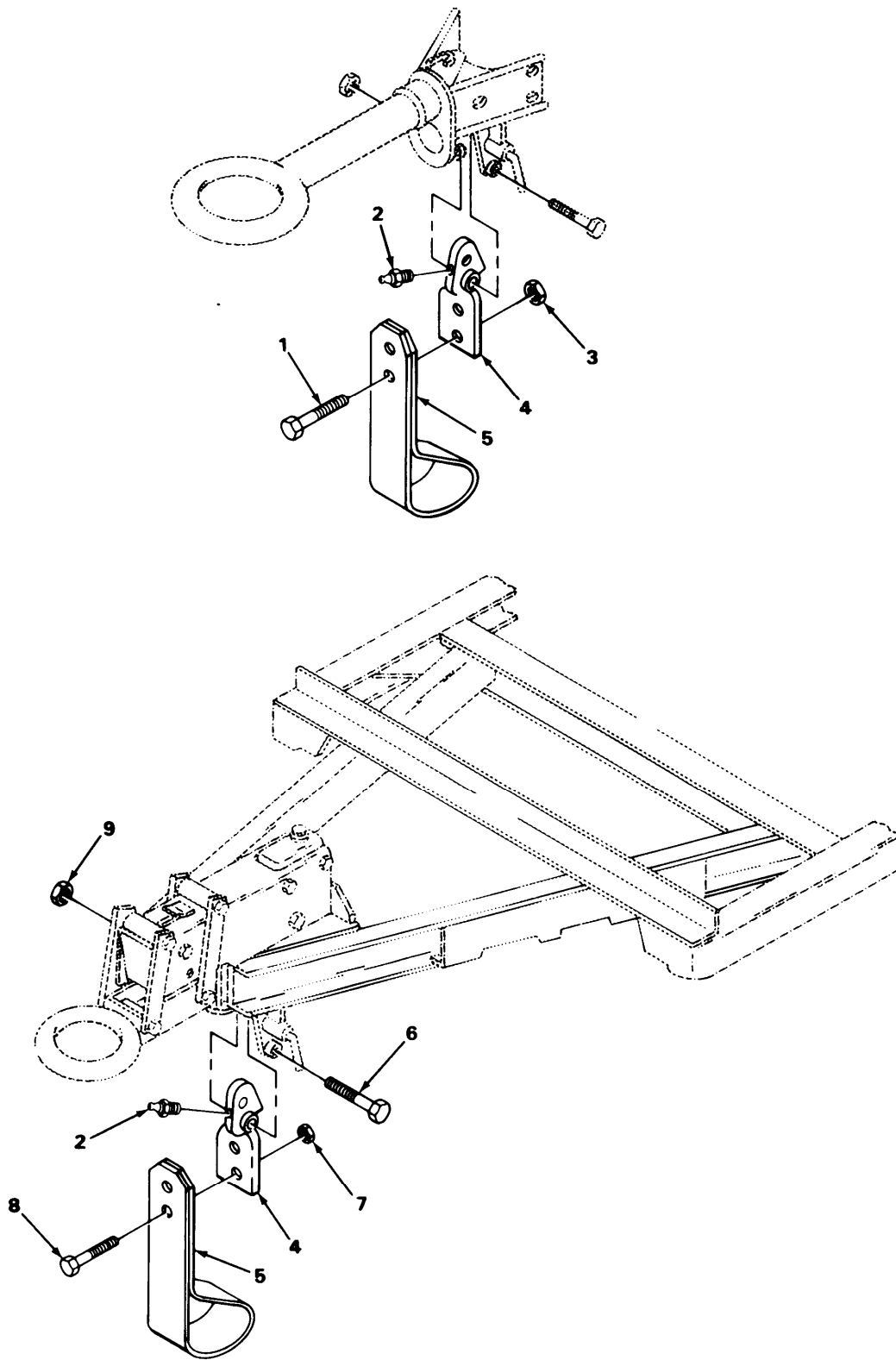

TA503169

FIGURE 16. LANDING LEG ASSEMBLY.

SECTION II		TM9-2330-251-14&P			
(1)	(2)	(3)	(4)	(5)	(6)
ITEM NO	SMR CODE	CAGEC	PART NUMBER	DESCRIPTION AND USABLE ON CODES (UOC)	QTY
				GROUP 1507 LANDING GEAR, LEVELING JACKS	
				FIG. 16 LANDING LEG ASSEMBLY	
1	PAOZZ	96906	MS90726-114	SCREW UOC:957	2
2	PAOZZ	96906	MS15003-1	FITTING, DRAWBAR BRACKET	1
3	PAOZZ	96906	MS21044N8	NUT, SELF-LOCKING, HE UOC:957	2
4	PAOZZ	19207	10924578	BRACKET, DRAWBAR COUPLER	1
5	PAOZZ	19207	7343007	LEG LANDING	1
6	PAOZZ	96906	MS90727-193	SCREW, CAP, HEXAGON H UOC:U69	1
7	PAOZZ	96906	MS21044N8	NUT, SELF-LOCKING, HE UOC:U69	2
8	PAOZZ	96906	MS90726-114	SCREW, CAP, HEXAGON H UOC:U69	2
9	PAOZZ	96906	MS51922-61	NUT, SELF-LOCKING UOC:U69	1
				END OF FIGURE	

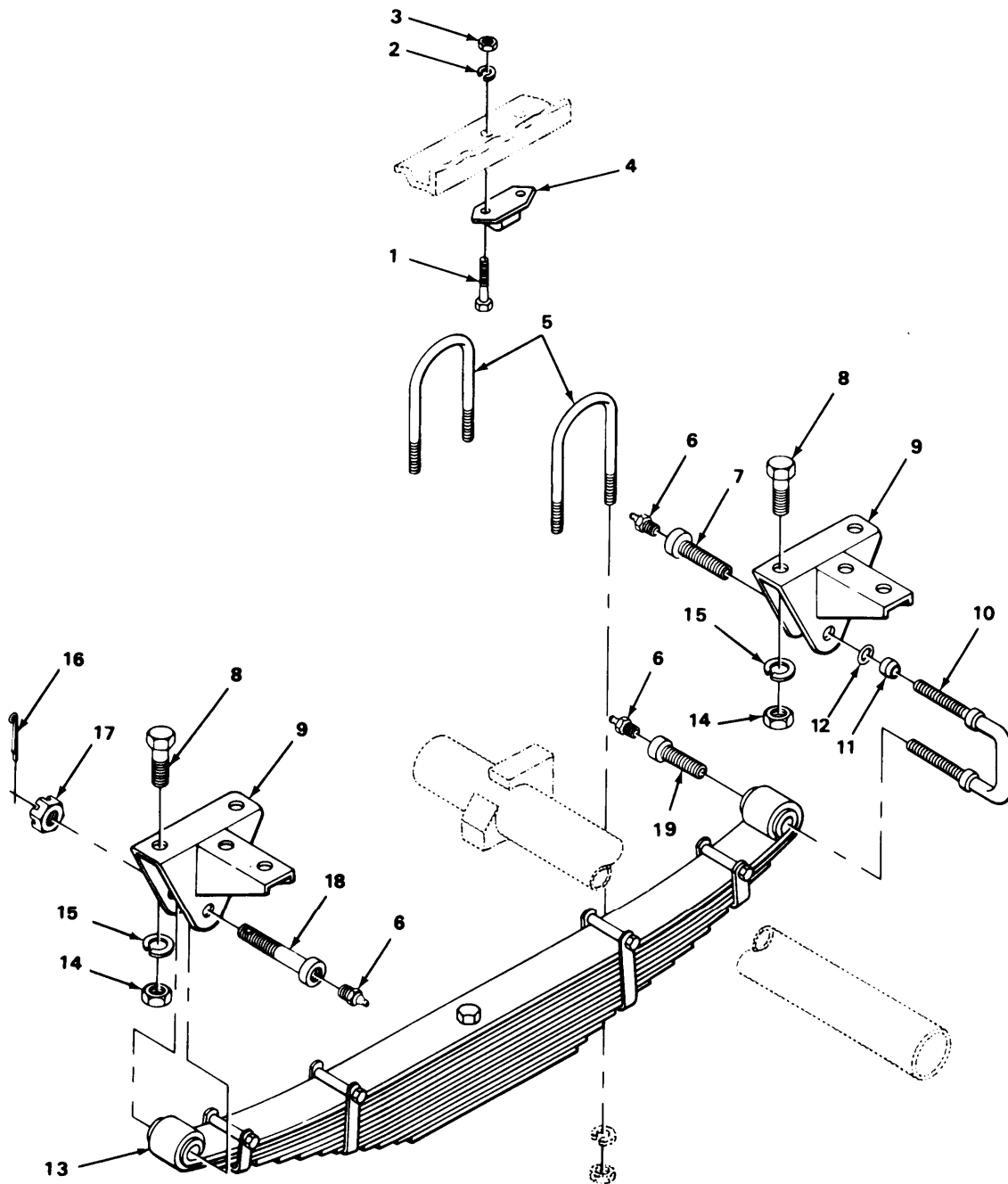

TA503170

FIGURE 17. SPRING ASSEMBLY.

SECTION II		TM9-2330-251-14&P			
(1)	(2)	(3)	(4)	(5)	(6)
ITEM	SMR		PART		
NO	CODE	CAGEC	NUMBER	DESCRIPTION AND USABLE ON CODES (UOC)	QTY
				GROUP 16 SPRINGS AND SHOCK ABSORBERS	
				GROUP 1601 SPRINGS	
				FIG. 17 SPRING ASSEMBLY	
1	PAOZZ	96906	MS90727-32	BOLT,MACHINE	4
2	PAOZZ	96906	MS35338-45	WASHER,LOCK	4
3	PAOZZ	96906	MS51968-5	NUT,PLAIN,HEXAGON COUPLER BRACKET	4
4	PFOZZ	19207	7338987	BUMPER,NONMETALLIC	2
5	PAOZZ	19207	7328295-1	BOLT,U SPRING	4
6	PAOZZ	96906	MS15003-1	FITTING, SPRING BUSHINGS	6
7	PAOZZ	19207	7328324	BEARING, BUSHING REAR SHACKLE RIGHT	1
8	PAOZZ	96906	MS90726-60	SCREW,CAP,HEXAGON H	8
9	PAOZZ	19207	10924593	BRACKET,EYE,ROTATIN	2
10	PAOZZ	19207	7371090	BOLT,U BOLT, REAR RIGHT	1
10	PAOZZ	23040	GPW5779	SHACKLE,LEAF SPRING LEFT REAR	1
11	PAOZZ	03677	7328322	RETAINER, SPRING	4
12	PAOZZ	19207	7328323	BUSHING, RUBBER SPRING SHACKLE	4
13	PAOZZ	19207	11669331	SPRING ASSEMBLY,LEA	2
14	PAOZZ	96906	MS51968-8	NUT,PLAIN,HEXAGON	8
15	PAOZZ	96906	MS35338-46	WASHER,LOCK	8
16	PAOZZ	96906	MS24665-353	PIN,COTTER	2
17	PAOZZ	96906	MS35692-45	NUT, FLUID PASSAGE BOLT	2
18	PAOZZ	19207	7328328	BOLT,INTERNALLY REL SPRING	2
19	PAOZZ	22852	801244	BUSHING,SUSPENSION LEFT AND LOWER	3

END OF FIGURE

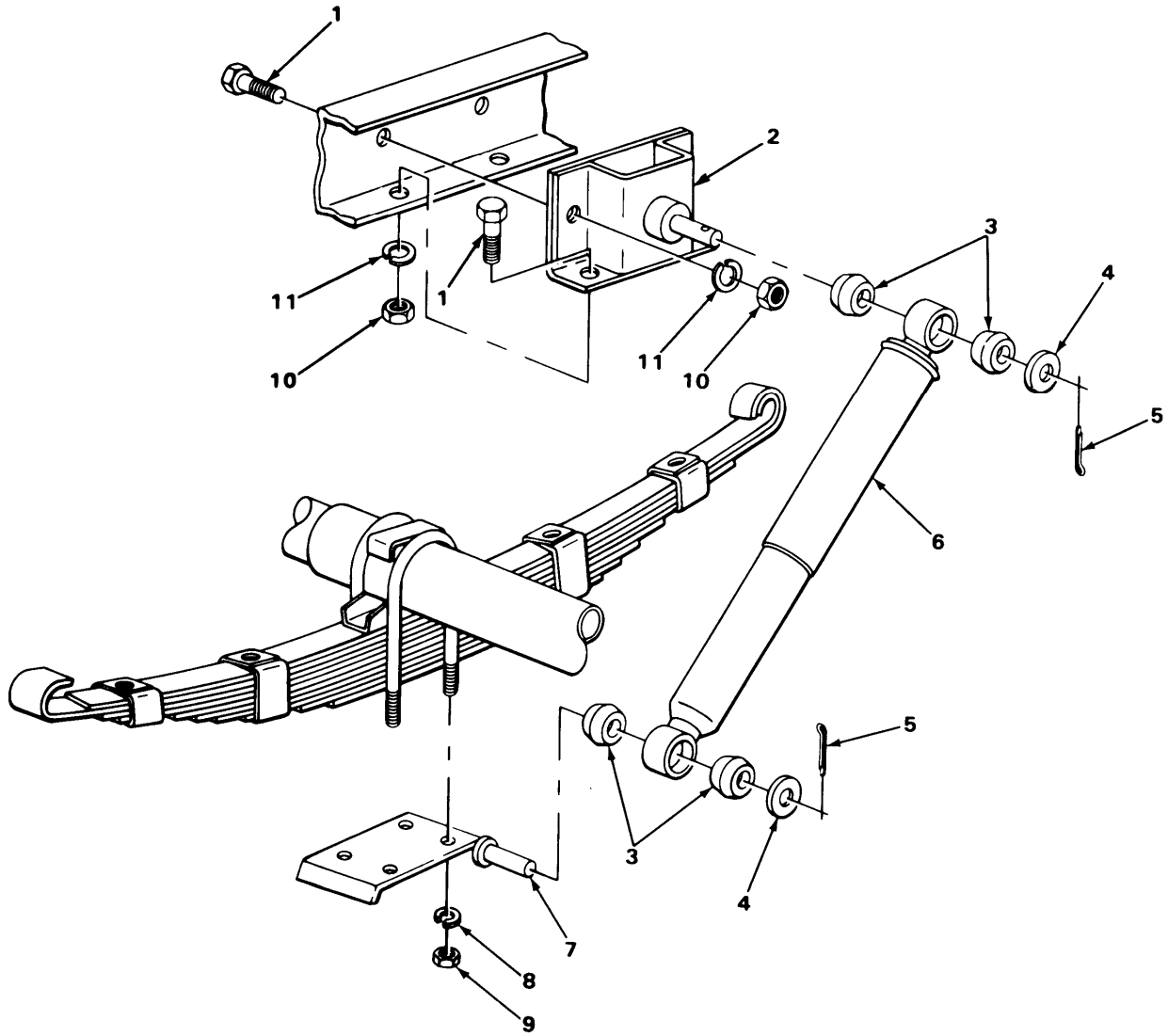

TA503171

FIGURE 18. SHOCK ABSORBER.

SECTION II		TM9-2330-251-14&P			
(1)	(2)	(3)	(4)	(5)	(6)
ITEM NO	SMR CODE	CAGEC	PART NUMBER	DESCRIPTION AND USABLE ON CODES (UOC)	QTY
GROUP 1604 SHOCK ABSORBER EQUIPMENT					
FIG. 18 SHOCK ABSORBER					
1	PFOZZ	96906	MS90726-60	SCREW,CAP,HEXAGON H	8
2	PAOZZ	19207	10924584	BRACKET,MOUNTING SHOCK ABSORBER	2
3	PAOZZ	19207	7343032	BUSHING, RUBBER SHOCK ABSORBER	8
4	PAOZZ	96906	MS27183-21	WASHER,FLAT	4
5	PAOZZ	96906	MS24665-491	PIN,COTTER FLUID PASSAGE BOLT	2
6	PAOZZ	76445	18459	SHOCK ABSORBER,DIRE SUSPENSION	2
7	PAOZZ	19207	7697848	PLATE AND SHAFT ASS RIGHT SPRING	1
7	PAOZZ	23040	GPW5459	PLATE ASSEMBLY LEFT SPRING	1
8	PAOZZ	96906	MS35338-47	WASHER, LOCK-SPRING U-BOLT	8
9	PAOZZ	19207	7328296	NUT, PLAIN, HEXAGON U-BOLT	8
10	PAOZZ	96906	MS51968-8	NUT, PLAIN, HEXAGON LEVER ATTACHING	8
11	PAOZZ	96906	MS35338-46	WASHER,LOCK	8

END OF FIGURE

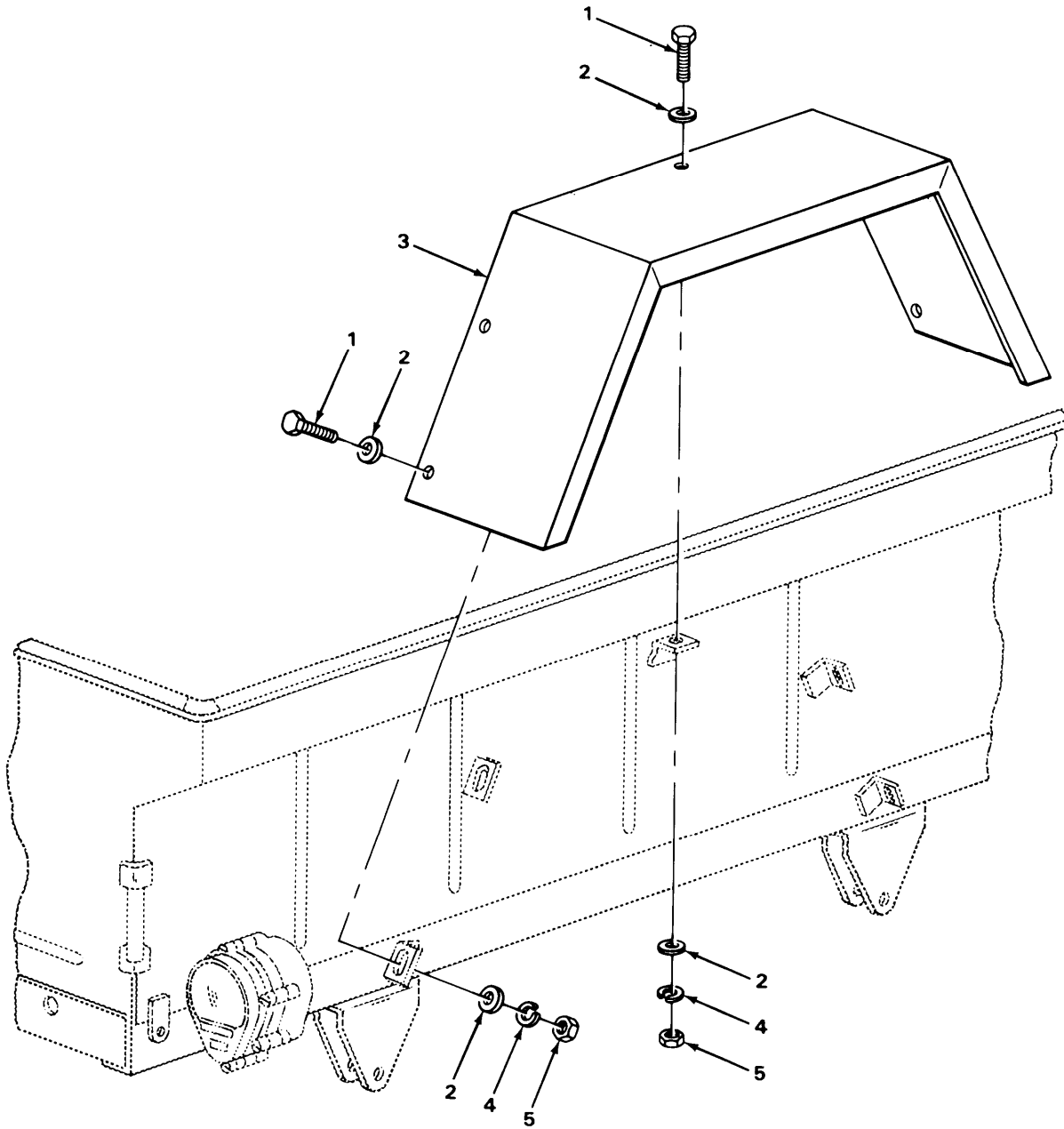

TA503172

FIGURE 19. FENDERS.

SECTION II		TM9-2330-251-14&P			
(1)	(2)	(3)	(4)	(5)	(6)
ITEM NO	SMR CODE	CAGEC	PART NUMBER	DESCRIPTION AND USABLE ON CODES (UOC)	QTY
				GROUP 18 BODY	
				GROUP 1802 FENDERS	
				FIG. 19 FENDERS	
1	PAOZZ	96906	MS18154-58	SCREW,CAP,HEXAGON H	10
2	PAOZZ	96906	MS27183-14	WASHER,FLAT	20
3	PAOZZ	19207	10924564	FENDER,VEHICULAR	2
4	PAOZZ	96906	MS35338-46	WASHER,LOCK	10
5	PAOZZ	96906	MS51968-8	NUT,PLAIN,HEXAGON	10
				END OF FIGURE	

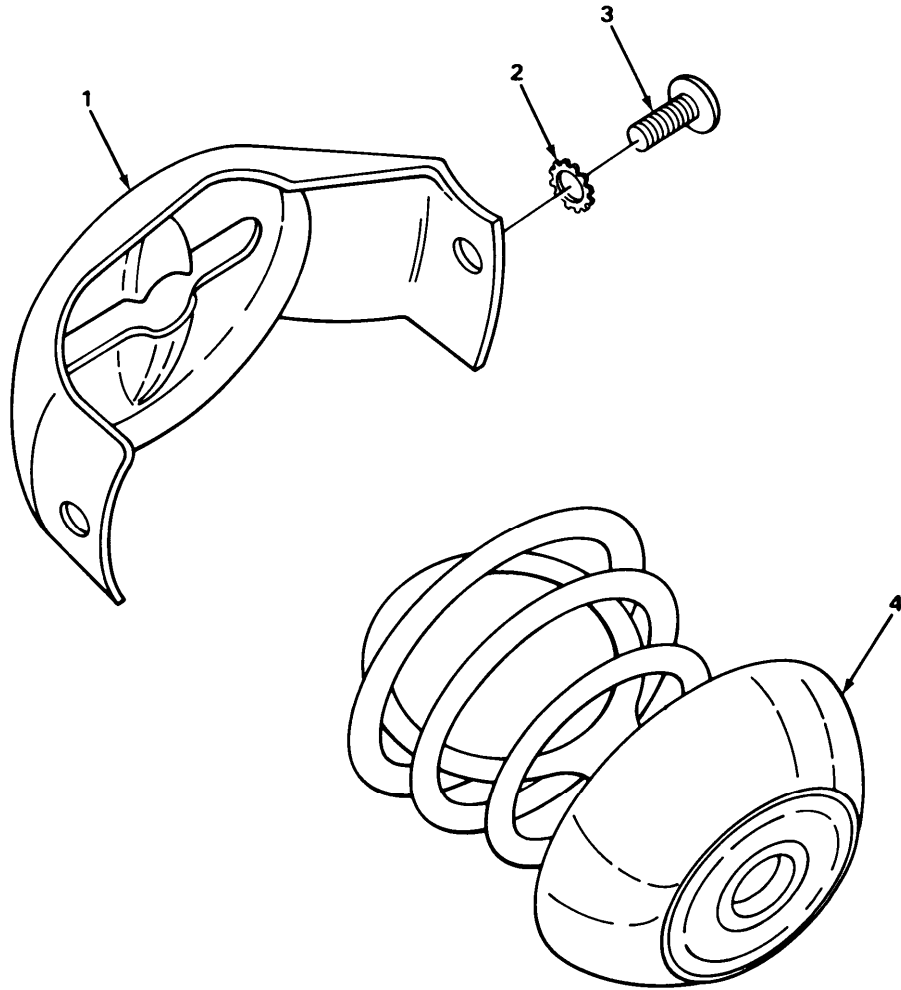

TA503173

FIGURE 20. DRAIN VALVE ASSEMBLY.

SECTION II		TM9-2330-251-14&P			
(1)	(2)	(3)	(4)	(5)	(6)
ITEM NO	SMR CODE	CAGEC	PART NUMBER	DESCRIPTION AND USABLE ON CODES (UOC)	QTY
				GROUP 1804 DRAIN VALVES, DRAIN PLUGS, ETC.	
				FIG. 20 DRAIN VALVE ASSEMBLY	
1	PAOZZ	19207	7328340	SUPPORT, DRAIN CARGO BODY	2
2	PAOZZ	96906	MS35335-32	WASHER, LOCK	4
3	PAOZZ	96906	MS35207-261	SCREW, VALVE SUPPORT	4
4	PAOZZ	19207	7328336	VALVE ASSEMBLY DRAIN	2
				END OF FIGURE	

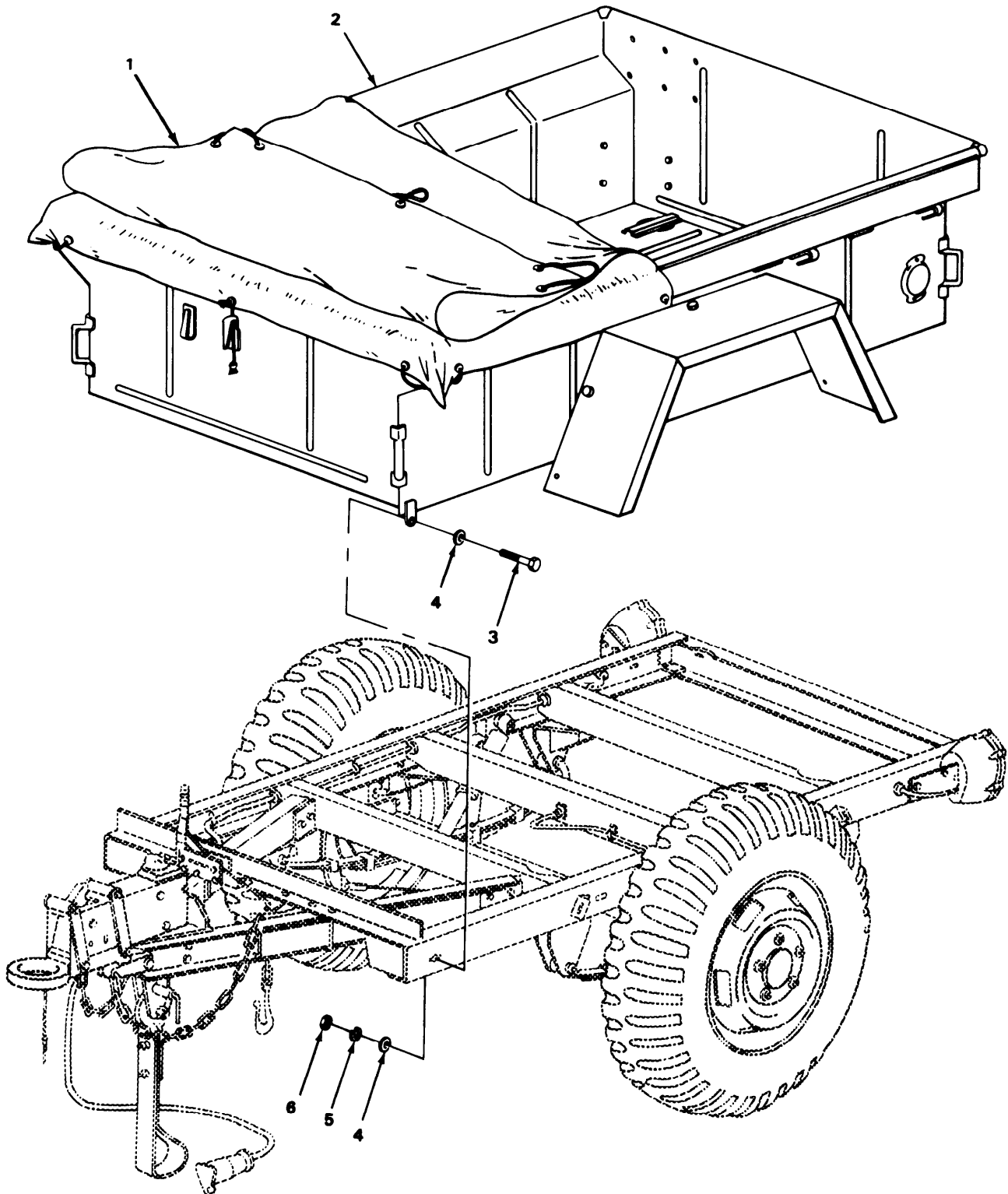

TA503174

FIGURE 21. BODY.

SECTION II		TM9-2330-251-14&P			
(1)	(2)	(3)	(4)	(5)	(6)
ITEM NO	SMR CODE	CAGEC	PART NUMBER	DESCRIPTION AND USABLE ON CODES (UOC)	QTY
				GROUP 1810 CARGO BODY	
				FIG. 21 BODY	
1	PAOZZ	19207	10913205	TARPAULIN CARGO BODY	1
2	PAOFF	19207	10924559	BODY, CARGO TRAILER	1
3	PAOZZ	96906	MS90728-59	SCREW, CAP, HEXAGON H	8
4	PAOZZ	96906	MS27183-14	WASHER, FLAT	16
5	PAOZZ	96906	MS35338-46	WASHER, LOCK	8
6	PAOZZ	96906	MS51968-8	NUT, PLAIN, HEXAGON	8
				END OF FIGURE	

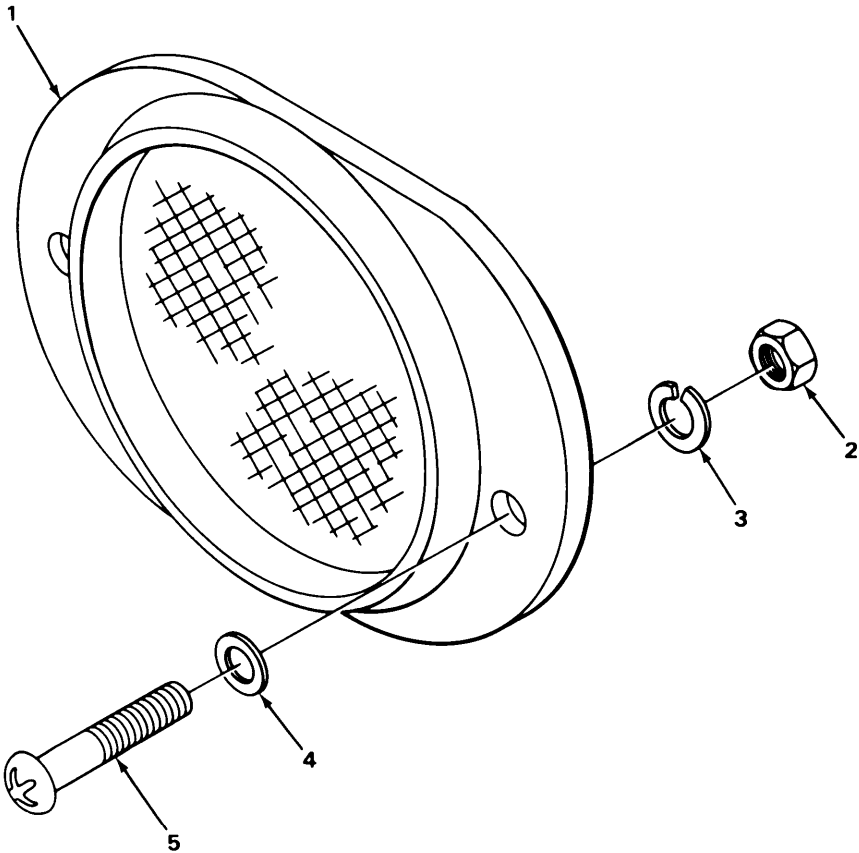

FIGURE 22. REFLECTORS.

SECTION II		TM9-2330-251-14&P			
(1)	(2)	(3)	(4)	(5)	(6)
ITEM NO	SMR CODE	CAGEC	PART NUMBER	DESCRIPTION AND USABLE ON CODES (UOC)	QTY
GROUP 22 BODY ACCESSORY ITEMS					
GROUP 2202 ACCESSORY ITEMS					
FIG. 22 REFLECTORS					
1	PAOZZ	96906	MS35387-1	REFLECTOR, RED LENS	4
2	PAOZZ	96906	MS51968-8	NUT, PLAIN, HEXAGON	8
3	PAOZZ	96906	MS35338-44	WASHER, LOCK	8
4	PAOZZ	19207	7328316	WASHER, FLAT	8
5	PAOZZ	96906	MS35207-279	SCREW, MACHINE	8
END OF FIGURE					

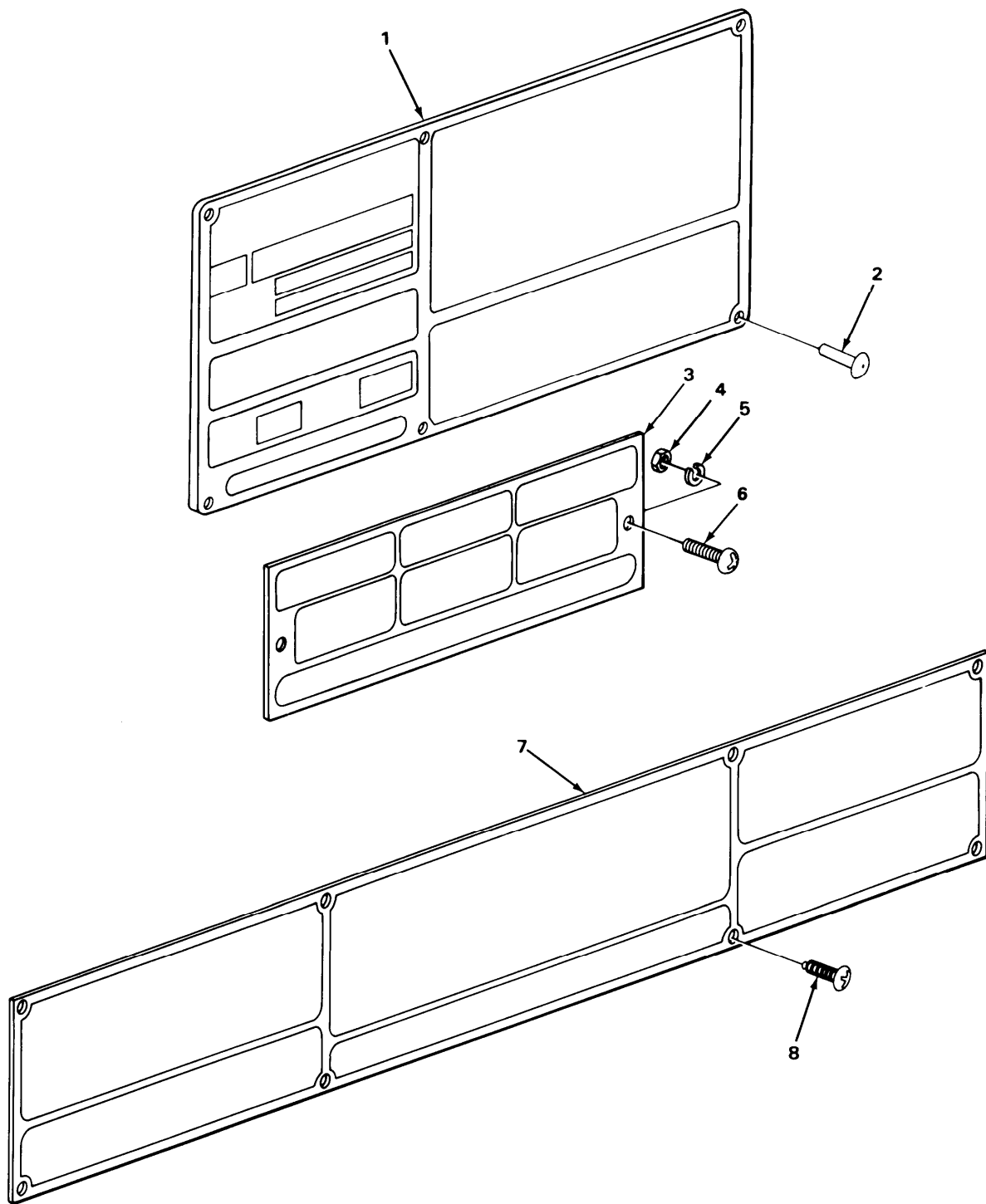

FIGURE 23. DATA PLATES.

SECTION II		TM9-2330-251-14&P			
(1)	(2)	(3)	(4)	(5)	(6)
ITEM NO	SMR CODE	CAGEC	PART NUMBER	DESCRIPTION AND USABLE ON CODES (UOC)	QTY
GROUP 2210 DATA PLATES					
FIG. 23 DATA PLATES					
1	PDOZZ	19207	11625506	PLATE, IDENTIFICATIO UOC:U69	1
1	PAOZZ	19207	10924556	PLATE, IDENTIFICATIO UOC:957	1
2	XDOZZ	96906	MS20450C96	RIVET, TUBULAR	6
3	PAOZZ	19207	7979373	PLATE, IDENTIFICATIO	1
4	PAOZZ	96906	MS51968-2	NUT, PLAIN, HEXAGON	2
5	PAOZZ	96906	MS35338-44	WASHER, LOCK	2
6	PAOZZ	96906	MS35207-279	SCREW, MACHINE	2
7	XDOZZ	19207	11625507	PLATE, IDENTIFICATIO UOC:U69	1
7	XDOZZ	19207	10924608	PLATE, IDENTIFICATIO UOC:957	1
8	PAOZZ	96906	MS24629-45	SCREW, TAPPING, THREA	8
END OF FIGURE					

SECTION II					
(1)	(2)	(3)	TM9-2330-251-14&P	(5)	(6)
ITEM	SMR		PART		
NO	CODE	CAGEC	NUMBER	DESCRIPTION AND USABLE ON CODES (UOC)	QTY
				GROUP 95 GENERAL USE STANDARDIZED PARTS	
				GROUP 9501 BULK MATERIEL	
				FIG. BULK	
1	PAOZZ	19207	10943231	TUBE,BENT,METALLIC	V
				END OF FIGURE	

BULK-1

CROSS-REFERENCE INDEXES

NATIONAL STOCK NUMBER INDEX

STOCK NUMBER	FIG	ITEM	STOCK NUMBER	FIG	ITEM
5315-00-012-0123	11	10	5305-00-269-2803	18	1
4730-00-014-2431	9	1	5305-00-269-3210	1	18
6240-00-019-0877	1	6	5305-00-269-3236	6	12
	1	11	5305-00-269-3242	5	19
	1	32	5305-00-269-3248	8	1
6240-00-019-3093	1	28		15	13
6240-00-044-6914	1	10	9905-00-282-7489	23	3
	1	27	4730-00-289-5176	13	3
5315-00-045-4217	13	4		15	24
	15	16	5330-00-297-7106	1	9
2640-00-050-1229	12	4	2530-00-350-8707	10	9
5306-00-050-1238	1	33	2610-00-350-9975	12	2
	5	15	5315-00-352-1909	6	10
	17	1	5340-00-371-4134	9	16
4730-00-050-4208	13	6	3040-00-404-0750	10	6
	16	2	5310-00-407-9566	1	15
	17	6		1	34
5340-00-057-2891	3	17		5	14
5340-00-057-3537	5	21		17	2
5310-00-057-7080	14	4	6220-00-433-5966	1	5
	15	9	5330-00-462-0907	1	26
5315-00-059-0206	18	5	6220-00-500-0437	1	12
2640-00-060-3550	12	3	5310-00-582-5965	2	17
5310-00-061-1258	1	13		9	10
5310-00-080-6004	19	2		22	3
	21	4		23	5
1015-00-087-2833	6	11	5310-00-584-5272	6	15
4710-00-102-0108	BULK	1		14	6
5305-00-115-9526	1	22	5310-00-596-7691	2	13
	1	30		3	13
	19	1		20	2
3040-00-116-5171	6	2	5310-00-637-9541	1	19
5315-00-143-6323	5	18		1	29
2530-00-150-7832	10	10		5	3
	11	12		6	17
2530-00-161-7575	8	8		17	15
2530-00-161-7576	8	8		18	11
5310-00-177-1329	11	13		19	4
5340-00-177-7832	2	14		21	5
2530-00-177-8097	6	6	5360-00-663-3110	13	5
5360-00-200-7022	13	8		15	15
9905-00-205-2795	22	1	5360-00-664-5344	7	14
4730-00-206-1384	17	18	5360-00-664-7691	6	4
5310-00-209-0965	7	2	6220-00-669-5623	1	7
	18	8	2610-00-678-1363	12	1
5305-00-225-9091	5	22	5330-00-678-1759	10	3
5305-00-226-7767	14	7	3110-00-678-1862	10	5
5340-00-253-1910	11	11	5330-00-678-9047	1	4
5305-00-267-8951	2	15	2530-00-690-2742	6	7
5305-00-269-2803	17	8	5315-00-699-8495	5	5

CROSS-REFERENCE INDEXES

NATIONAL STOCK NUMBER INDEX

STOCK NUMBER	FIG	ITEM	STOCK NUMBER	FIG	ITEM
2590-00-705-8970	20	1	2540-00-769-7442	18	6
5305-00-709-8423	15	12	2510-00-769-7598	17	19
5305-00-709-8517	7	6	2510-00-769-7848	18	7
	13	13	2510-00-773-5833	17	10
	14	2	2510-00-774-0886	19	3
5305-00-725-4187	16	1	6220-00-775-2384	1	3
	16	8	5340-00-778-2738	9	3
3110-00-727-6901	10	4	5340-00-781-6308	13	16
5305-00-728-5474	16	6	5310-00-809-4058	9	9
5305-00-728-5475	14	9	5310-00-809-8533	11	8
5310-00-732-0559	1	14	5310-00-823-8803	18	4
	5	4	3110-00-827-8648	11	7
	6	18	5310-00-832-9719	14	1
	17	14		16	9
	18	10	5315-00-839-5820	6	14
	19	5	5315-00-839-5822	17	16
	21	6	5310-00-842-1488	5	7
	22	2	5315-00-842-3044	5	6
5310-00-732-0560	6	16	5315-00-842-3651	5	17
	14	5	6220-00-846-9745	1	1
5340-00-732-8267	1	23	5310-00-850-6884	17	17
5340-00-732-8268	1	16	5310-00-850-6993	11	9
5310-00-732-8296	18	9	5306-00-850-7069	10	2
2540-00-732-8311	13	17	5320-00-852-1082	6	8
5310-00-732-8312	13	7	5305-00-855-0956	2	12
5310-00-732-8314	13	9		3	12
5310-00-732-8316	22	4	5305-00-855-0958	9	2
5330-00-732-8322	17	11		23	8
5365-00-732-8323	17	12	5305-00-855-0964	3	18
5340-00-732-8324	17	7	6150-00-855-9304	2	1
4010-00-732-8329	5	13	5340-00-860-0555	3	14
5340-00-732-8331	5	16	2540-00-863-5598	21	1
3040-00-732-8332	5	8	2530-00-863-5599	10	1
5306-00-732-8333	5	12	4010-00-863-5601	13	2
2530-00-732-8334	5	10	2590-00-863-5602	3	1
4820-00-732-8336	20	4	2530-00-863-5603	5	11
2510-00-734-3007	16	5	2530-00-863-5607	6	9
5365-00-734-3032	18	3	2530-00-863-5609	6	7
2510-00-734-3076	18	7	3040-00-870-2108	5	1
5306-00-737-1090	17	10	5310-00-877-5795	15	4
2530-00-737-7747	6	13		16	3
2530-00-737-7748	6	13		16	7
5310-00-761-6882	9	11	5310-00-880-7745	7	1
3110-00-763-0259	11	2	5310-00-880-7746	1	35
5305-00-764-0070	1	2		5	9
5310-00-768-0319	2	18		17	3
	23	4	2530-00-902-3618	6	3
3110-00-769-1426	11	3	5340-00-912-8871	2	16
5310-00-769-6520	10	12	3110-00-926-1379	11	6
5310-00-769-6521	10	7	5360-00-930-5644	7	15

CROSS-REFERENCE INDEXES

NATIONAL STOCK NUMBER INDEX

STOCK NUMBER	FIG	ITEM	STOCK NUMBER	FIG	ITEM
5340-00-937-1962	16	4	5340-01-148-6823	1	17
5330-00-953-1886	8	5	3040-01-154-1433	17	9
5310-00-959-1488	8	6	4010-01-158-6795	15	2
	15	8	5340-01-166-0783	1	36
5310-00-983-8483	5	20	5975-01-170-3480	3	15
5305-00-984-6208	9	7	5305-01-179-2304	8	7
5305-00-990-6444	20	3	5360-01-180-2292	7	12
5305-00-993-2463	22	5	2590-01-185-0168	15	10
	23	6	5340-01-185-2810	3	16
2530-01-032-6676	6	5	9905-01-205-6010	23	1
2590-01-042-9695	5	13	5310-01-213-9952	13	10
4730-01-043-3055	9	8	5340-01-244-5890	1	36
4720-01-043-5222	9	14	5315-01-257-2379	6	1
5330-01-044-1941	9	15	5340-01-257-3883	15	14
2540-01-050-7136	15	17	2530-01-264-0505	7	8
2530-01-050-7698	15	25	2540-01-271-0272	15	1
2530-01-050-7700	15	21	5306-01-282-8180	17	5
2530-01-050-8832	15	22			
2530-01-050-8929	8	3			
2540-01-051-6354	15	7			
2540-01-051-6355	15	5			
3120-01-052-1151	15	6			
2530-01-052-2895	11	4			
2530-01-052-5238	7	18			
2530-01-052-6019	7	9			
2530-01-053-2453	15	3			
5365-01-053-6898	8	2			
2530-01-054-1509	7	7			
5360-01-054-2281	15	23			
3040-01-054-2765	7	7			
2530-01-054-2905	7	4			
2530-01-054-3918	7	16			
5360-01-054-5023	7	17			
5315-01-054-5870	7	3			
5306-01-054-9238	11	5			
5330-01-055-3870	11	1			
5315-01-056-3053	7	5			
2530-01-058-2672	4	1			
2510-01-058-7420	17	13			
2530-01-058-7486	7	13			
2540-01-060-7031	15	19			
5340-01-087-9679	7	19			
6220-01-093-4439	1	24			
2510-01-111-7096	21	2			
9905-01-115-2313	23	1			
4730-01-123-3802	9	6			
5340-01-132-0889	18	2			
5340-01-132-4274	17	4			
5305-01-140-9118	21	3			
5340-01-144-1705	5	2			

CROSS-REFERENCE INDEXES

CAGEC	PART NUMBER	PART NUMBER INDEX STOCK NUMBER	FIG	ITEM
75828	EL53241-1	5360-00-200-7022	13	8
71770	FMC8317	4010-00-863-5601	13	2
71770	FMC8372	2530-00-863-5599	10	1
23040	GPW5459	2510-00-734-3076	18	7
23040	GPW5779	2510-00-773-5833	17	10
60038	L44610	3110-00-827-8648	11	7
60038	L44649	3110-00-926-1379	11	6
60038	L68111	3110-00-769-1426	11	3
60038	L68149	3110-00-763-0259	11	2
96906	MS15003-1	4730-00-050-4208	13	6
			16	2
			17	6
96906	MS15570-1251	6240-00-019-0877	1	6
			1	11
			1	32
96906	MS15570-623	6240-00-019-3093	1	28
96906	MS18154-58	5305-00-115-9526	1	22
			1	30
			19	1
96906	MS20365-820C		13	12
96906	MS20450C96		23	2
96906	MS20665-425		13	11
96906	MS21044N8	5310-00-877-5795	15	4
			16	3
			16	7
96906	MS21333-2	5340-00-778-2738	9	3
96906	MS21333-4	5340-00-057-2891	3	17
96906	MS21333-43	5340-00-912-8871	2	16
96906	MS24629-45	5305-00-855-0958	9	2
			23	8
96906	MS24629-47	5305-00-855-0956	2	12
			3	12
96906	MS24629-48	5305-00-855-0964	3	18
96906	MS24665-134	5315-00-839-5820	6	14
96906	MS24665-283	5315-00-842-3044	5	6
96906	MS24665-295	5315-00-842-3651	5	17
96906	MS24665-353	5315-00-839-5822	17	16
96906	MS24665-355	5315-00-012-0123	11	10
96906	MS24665-491	5315-00-059-0206	18	5
96906	MS25036-154		2	2
96906	MS27148-2		3	6
96906	MS27183-10	5310-00-809-4058	9	9
96906	MS27183-14	5310-00-080-6004	19	2
			21	4
96906	MS27183-21	5310-00-823-8803	18	4
96906	MS27183-23	5310-00-809-8533	11	8
96906	MS27183-5	5310-00-983-8483	5	20
96906	MS35206-261	5305-00-984-6208	9	7
96906	MS35207-261	5305-00-990-6444	20	3
96906	MS35207-279	5305-00-993-2463	22	5
			23	6

CROSS-REFERENCE INDEXES

CAGEC	PART NUMBER	PART NUMBER INDEX STOCK NUMBER	FIG	ITEM
96906	MS35291-59	5305-00-269-3210	1	18
96906	MS35335-32	5310-00-596-7691	2	13
			3	13
			20	2
96906	MS35338-44	5310-00-582-5965	2	17
			9	10
			22	3
			23	5
96906	MS35338-45	5310-00-407-9566	1	15
			1	34
			5	14
			17	2
96906	MS35338-46	5310-00-637-9541	1	19
			1	29
			5	3
			6	17
			17	15
			18	11
			19	4
			21	5
96906	MS35338-47	5310-00-209-0965	7	2
			18	8
96906	MS35338-48	5310-00-584-5272	6	15
			14	6
96906	MS35387-1	9905-00-205-2795	22	1
96906	MS35478-1683	6240-00-044-6914	1	10
			1	27
19207	MS35692-1426	5310-01-213-9952	13	10
96906	MS35692-21	5310-00-842-1488	5	7
96906	MS35692-45	5310-00-850-6884	17	17
96906	MS35692-62	5310-00-850-6993	11	9
96906	MS35812-3	5340-00-057-3537	5	21
96906	MS39020-1		3	10
96906	MS39134-1		2	10
96906	MS45904-76	5310-00-061-1258	1	13
02951	MS49005-8	4730-00-289-5176	13	3
			15	24
96906	MS51302-1	6220-00-846-9745	1	1
96906	MS51877-3	4730-01-123-3802	9	6
96906	MS51922-21	5310-00-959-1488	8	6
			15	8
96906	MS51922-29	5310-00-057-7080	14	4
			15	9
96906	MS51922-61	5310-00-832-9719	14	1
			16	9
96906	MS51959-46	5305-00-764-0070	1	2
96906	MS51967-2	5310-00-761-6882	9	11
96906	MS51968-11	5310-00-880-7745	7	1
96906	MS51968-14	5310-00-732-0560	6	16
			14	5
96906	MS51968-2	5310-00-768-0319	2	18

CROSS-REFERENCE INDEXES

CAGEC	PART NUMBER	PART NUMBER INDEX STOCK NUMBER	FIG	ITEM
96906	MS51968-2	5310-00-768-0319	23	4
96906	MS51968-5	5310-00-880-7746	1	35
			5	9
			17	3
96906	MS51968-8	5310-00-732-0559	1	14
			5	4
			6	18
			17	14
			18	10
			19	5
			21	6
			22	2
96906	MS52125-2	6220-01-093-4439	1	24
96906	MS53047-1	6220-00-500-0437	1	12
96906	MS53069-1	2530-00-350-8707	10	9
96906	MS90726-109	5305-00-226-7767	14	7
96906	MS90726-114	5305-00-725-4187	16	1
			16	8
96906	MS90726-36	5305-00-225-9091	5	22
96906	MS90726-60	5305-00-269-2803	17	8
			18	1
96906	MS90727-193	5305-00-728-5474	16	6
96906	MS90727-2	5305-00-267-8951	2	15
96906	MS90727-200	5305-00-728-5475	14	9
96906	MS90727-32	5306-00-050-1238	1	33
			5	15
			17	1
96906	MS90727-60	5305-00-269-3236	6	12
96906	MS90727-66	5305-00-269-3242	5	19
96906	MS90727-72	5305-00-269-3248	8	1
			15	13
96906	MS90727-85	5305-00-709-8517	7	6
			13	13
			14	2
96906	MS90727-97	5305-00-709-8423	15	12
96906	MS90728-59	5305-01-140-9118	21	3
81349	M13486-1-5		2	11
			3	11
81349	M13486/10-1		2	7
81349	M43436-1-1		2	6
81349	M43436-1-3		3	9
80205	NAS1611-128	5330-00-953-1886	8	5
51665	US48	2640-00-060-3550	12	3
33116	X-43438		10	11
33116	X43436	5306-00-850-7069	10	2
81348	ZZ-I-550/GP2/6.0 0-16/TR15/OFFCTR	2610-00-350-9975	12	2
17875	100AA	2640-00-050-1229	12	4
93072	10603	2590-01-185-0168	15	10
93072	10607	2530-01-050-7700	15	21
93072	10614	2530-01-050-8929	8	3

CROSS-REFERENCE INDEXES

CAGEC	PART NUMBER	PART NUMBER INDEX STOCK NUMBER	FIG	ITEM
93072	10632	2540-01-060-7031	15	19
19207	10913205	2540-00-863-5598	21	1
19207	10920594	3040-00-870-2108	5	1
19207	10921860	2530-00-150-7832	11	12
19207	10924552	2590-00-863-5602	3	1
19207	10924556	9905-01-205-6010	23	1
19207	10924559	2510-01-111-7096	21	2
19207	10924564	2510-00-774-0886	19	3
19207	10924576	5975-01-170-3480	3	15
19207	10924577	5340-00-781-6308	13	16
19207	10924578	5340-00-937-1962	16	4
19207	10924581	2530-00-863-5603	5	11
19207	10924584	5340-01-132-0889	18	2
19207	10924587-1		14	3
19207	10924587-2		14	3
19207	10924588	5340-01-148-6823	1	17
19207	10924593	3040-01-154-1433	17	9
19207	10924595		14	8
19207	10924596	5340-01-144-1705	5	2
19207	10924599		4	1
19207	10924603	3040-00-404-0750	10	6
19207	10924608		23	7
19207	10942507		5	23
19207	10943231	4710-00-102-0108	BULK	1
94189	10952	2530-01-052-5238	7	18
94189	10953	2530-01-052-6019	7	9
94189	10954	2530-01-058-7486	7	13
94189	10958	5360-01-054-5023	7	17
94189	10959	5315-01-054-5870	7	3
94189	10960	5360-01-180-2292	7	12
94189	10961	2530-01-264-0505	7	8
19207	11625310-1	5340-01-244-5890	1	36
19207	11625310-2	5340-01-166-0783	1	36
19207	11625487	2540-01-271-0272	15	1
19207	11625489	2590-01-042-9695	5	13
19207	11625492-1		9	13
19207	11625492-2		9	12
19207	11625493		9	5
19207	11625494		9	4
19207	11625495	4720-01-043-5222	9	14
19207	11625497	5330-01-044-1941	9	15
19207	11625498	2530-01-053-2453	15	3
19207	11625499	5340-01-257-3883	15	14
19207	11625500		15	11
19207	11625501	2530-01-058-2672	4	1
19207	11625505	5340-00-371-4134	9	16
19207	11625506	9905-01-115-2313	23	1
19207	11625507		23	7
19207	11630595	5310-00-177-1329	11	13
19207	11639519-2	5330-00-462-0907	1	26
19207	11639520		1	31

CROSS-REFERENCE INDEXES

CAGEC	PART NUMBER	PART NUMBER INDEX STOCK NUMBER	FIG	ITEM
19207	11639535		1	25
19207	11669331	2510-01-058-7420	17	13
19207	11721		1	20
19204	12010439	2530-01-032-6676	6	5
19207	120741		1	21
19207	12296386	4010-01-158-6795	15	2
19207	12301157	2530-00-150-7832	10	10
19207	12331725-2		8	4
12204	142431	4730-00-014-2431	9	1
94189	14286	5340-00-253-1910	11	11
94189	14771	5306-01-054-9238	11	5
94189	14886	5315-01-056-3053	7	5
94189	15529	5330-01-055-3870	11	1
94189	16092	3040-01-054-2765	7	7
94189	16756	2530-01-054-3918	7	16
93072	1745	3120-01-052-1151	15	6
93072	1756		15	20
93072	1804	2530-01-050-7698	15	25
93072	1808-1	2540-01-051-6355	15	5
94189	18147	2530-01-052-2895	11	4
93072	1828	5360-01-054-2281	15	23
93072	1829	2540-01-051-6354	15	7
93072	1840	2530-01-050-8832	15	22
93072	1841	5365-01-053-6898	8	2
93072	1844-2	2540-01-050-7136	15	17
76445	18459	2540-00-769-7442	18	6
93072	1855		15	18
24076	22043		5	21
33116	22377	5315-00-352-1909	6	10
94189	24636	2530-01-054-2905	7	4
14894	308430-L	2530-01-054-1509	7	7
23705	325118	5315-00-699-8495	5	5
23040	360403S7A1		13	1
06853	39244	5360-00-930-5644	7	15
19207	428829		13	15
70142	47179-13	3040-00-116-5171	6	2
80201	516992	5330-00-678-1759	10	3
19207	5303469	5360-00-664-5344	7	14
19207	5304063	2530-00-863-5607	6	9
19207	5304070	1015-00-087-2833	6	11
73331	5942528	5330-00-678-9047	1	4
19207	595444		13	14
19207	7001417	5315-00-045-4217	13	4
			15	16
94833	73-1438	5360-00-663-3110	13	5
03677	73-1483	3040-00-732-8332	5	8
19207	7320658	5330-00-297-7106	1	9
19207	7324344	2530-00-902-3618	6	3
19207	7328267	5340-00-732-8267	1	23
19207	7328268	5340-00-732-8268	1	16
19207	7328295-1	5306-01-282-8180	17	5

CROSS-REFERENCE INDEXES

CAGEC	PART NUMBER	PART NUMBER INDEX STOCK NUMBER	FIG	ITEM
19207	7328296	5310-00-732-8296	18	9
19207	7328310	5360-00-663-3110	15	15
19207	7328311	2540-00-732-8311	13	17
19207	7328312	5310-00-732-8312	13	7
19207	7328314	5310-00-732-8314	13	9
19207	7328316	5310-00-732-8316	22	4
03677	7328322	5330-00-732-8322	17	11
19207	7328323	5365-00-732-8323	17	12
19207	7328324	5340-00-732-8324	17	7
19207	7328328	4730-00-206-1384	17	18
19207	7328329	4010-00-732-8329	5	13
19207	7328331	5340-00-732-8331	5	16
19207	7328333	5306-00-732-8333	5	12
19207	7328334	2530-00-732-8334	5	10
19207	7328336	4820-00-732-8336	20	4
19207	7328340	2590-00-705-8970	20	1
19207	7338987	5340-01-132-4274	17	4
19207	7342996	2610-00-678-1363	12	1
19207	7343007	2510-00-734-3007	16	5
19207	7343032	5365-00-734-3032	18	3
19207	7358188		2	9
19207	7371090	5306-00-737-1090	17	10
21450	7371106		10	8
19207	7375064		3	5
19207	7377747	2530-00-737-7747	6	13
19207	7377748	2530-00-737-7748	6	13
18355	7526020		1	8
19207	7536132	3110-00-678-1862	10	5
19207	7696520	5310-00-769-6520	10	12
19207	7696521	5310-00-769-6521	10	7
19207	7697848	2510-00-769-7848	18	7
19207	7735847	5315-00-143-6323	5	18
79470	7805	4730-01-043-3055	9	8
19207	7971302	5315-01-257-2379	6	1
19207	7979250	5340-01-185-2810	3	16
19207	7979373	9905-00-282-7489	23	3
22852	801244	2510-00-769-7598	17	19
19207	8338561		2	5
			3	8
19207	8338562		2	4
			3	3
19207	8338564		2	3
			3	4
19207	8338566		3	2
19207	8338567		3	7
19207	8378785	6220-00-669-5623	1	7
19207	8382973	5340-00-177-7832	2	14
12603	854584	5360-00-664-7691	6	4
19207	8678964	2530-00-177-8097	6	6
19207	8678967	2530-00-690-2742	6	7
19207	8678969	2530-00-863-5609	6	7

CROSS-REFERENCE INDEXES

CAGEC	PART NUMBER	PART NUMBER INDEX STOCK NUMBER	FIG	ITEM
19207	8701138	5320-00-852-1082	6	8
19207	8722864	6150-00-855-9304	2	1
19207	8722870	5340-00-860-0555	3	14
19207	8724316		2	8
19207	8741646	6220-00-775-2384	1	3
19207	8741650	6220-00-433-5966	1	5
19207	8762093	3110-00-727-6901	10	4
94189	9254	5340-01-087-9679	7	19
94189	9776	2530-00-161-7575	8	8
94189	9777	2530-00-161-7576	8	8
94189	9778	5305-01-179-2304	8	7
94189	9789		7	11
94189	9795		7	10

CROSS-REFERENCE INDEXES

FIG	ITEM	FIGURE AND ITEM NUMBER INDEX		PART NUMBER
		STOCK NUMBER	CAGEC	
BULK	1	4710-00-102-0108	19207	10943231
1	1	6220-00-846-9745	96906	MS51302-1
1	2	5305-00-764-0070	96906	MS51959-46
1	3	6220-00-775-2384	19207	8741646
1	4	5330-00-678-9047	73331	5942528
1	5	6220-00-433-5966	19207	8741650
1	6	6240-00-019-0877	96906	MS15570-1251
1	7	6220-00-669-5623	19207	8378785
1	8		18355	7526020
1	9	5330-00-297-7106	19207	7320658
1	10	6240-00-044-6914	96906	MS35478-1683
1	11	6240-00-019-0877	96906	MS15570-1251
1	12	6220-00-500-0437	96906	MS53047-1
1	13	5310-00-061-1258	96906	MS45904-76
1	14	5310-00-732-0559	96906	MS51968-8
1	15	5310-00-407-9566	96906	MS35338-45
1	16	5340-00-732-8268	19207	7328268
1	17	5340-01-148-6823	19207	10924588
1	18	5305-00-269-3210	96906	MS35291-59
1	19	5310-00-637-9541	96906	MS35338-46
1	20		19207	11721
1	21		19207	120741
1	22	5305-00-115-9526	96906	MS18154-58
1	23	5340-00-732-8267	19207	7328267
1	24	6220-01-093-4439	96906	MS52125-2
1	25		19207	11639535
1	26	5330-00-462-0907	19207	11639519-2
1	27	6240-00-044-6914	96906	MS35478-1683
1	28	6240-00-019-3093	96906	MS15570-623
1	29	5310-00-637-9541	96906	MS35338-46
1	30	5305-00-115-9526	96906	MS18154-58
1	31		19207	11639520
1	32	6240-00-019-0877	96906	MS15570-1251
1	33	5306-00-050-1238	96906	MS90727-32
1	34	5310-00-407-9566	96906	MS35338-45
1	35	5310-00-880-7746	96906	MS51968-5
1	36	5340-01-166-0783	19207	116235310-2
1	36	5340-01-244-5890	19207	11625310-1
2	1	6150-00-855-9304	19207	8722864
2	2		96906	MS25036-154
2	3		19207	8338564
2	4		19207	8338562
2	5		19207	8338561
2	6		81349	M43436-1-1
2	7		81349	M13486/10-1
2	8		19207	8724316
2	9		19207	7358188
2	10		96906	MS39134-1
2	11		81349	M13486-1-5
2	12	5305-00-855-0956	96906	MS24629-47
2	13	5310-00-596-7691	96906	MS35335-32

CROSS-REFERENCE INDEXES

FIGURE AND ITEM NUMBER INDEX				
FIG	ITEM	STOCK NUMBER	CAGEC	PART NUMBER
2	14	5340-00-177-7832	19207	8382973
2	15	5305-00-267-8951	96906	MS90727-2
2	16	5340-00-912-8871	96906	MS21333-43
2	17	5310-00-582-5965	96906	MS35338-44
2	18	5310-00-768-0319	96906	MS51968-2
3	1	2590-00-863-5602	19207	10924552
3	2		19207	8338566
3	3		19207	8338562
3	4		19207	8338564
3	5		19207	7375064
3	6		96906	MS27148-2
3	7		19207	8338567
3	8		19207	8338561
3	9		81349	M43436-1-3
3	10		96906	MS39020-1
3	11		81349	M13486-1-5
3	12	5305-00-855-0956	96906	MS24629-47
3	13	5310-00-596-7691	96906	MS35335-32
3	14	5340-00-860-0555	19207	8722870
3	15	5975-01-170-3480	19207	10924576
3	16	5340-01-185-2810	19207	7979250
3	17	5340-00-057-2891	96906	MS21333-4
3	18	5305-00-855-0964	96906	MS24629-48
4	1		19207	10924599
4	1	2530-01-058-2672	19207	11625501
5	1	3040-00-870-2108	19207	10920594
5	2	5340-01-144-1705	19207	10924596
5	3	5310-00-637-9541	96906	MS35338-46
5	4	5310-00-732-0559	96906	MS51968-8
5	5	5315-00-699-8495	23705	325118
5	6	5315-00-842-3044	96906	MS24665-283
5	7	5310-00-842-1488	96906	MS35692-21
5	8	3040-00-732-8332	03677	73-1483
5	9	5310-00-880-7746	96906	MS51968-5
5	10	2530-00-732-8334	19207	7328334
5	11	2530-00-863-5603	19207	10924581
5	12	5306-00-732-8333	19207	7328333
5	13	2590-01-042-9695	19207	11625489
5	13	4010-00-732-8329	19207	7328329
5	14	5310-00-407-9566	96906	MS35338-45
5	15	5306-00-050-1238	96906	MS90727-32
5	16	5340-00-732-8331	19207	7328331
5	17	5315-00-842-3651	96906	MS24665-295
5	18	5315-00-143-6323	19207	7735847
5	19	5305-00-269-3242	96906	MS90727-66
5	20	5310-00-983-8483	96906	MS27183-5
5	21		24076	22043
5	21	5340-00-057-3537	96906	MS35812-3
5	22	5305-00-225-9091	96906	MS90726-36
5	23		19207	10942507
6	1	5315-01-257-2379	19207	7971302

CROSS-REFERENCE INDEXES

FIG	ITEM	FIGURE AND ITEM NUMBER INDEX		PART NUMBER
		STOCK NUMBER	CAGEC	
6	2	3040-00-116-5171	70142	47179-13
6	3	2530-00-902-3618	19207	7324344
6	4	5360-00-664-7691	12603	854584
6	5	2530-01-032-6676	19204	12010439
6	6	2530-00-177-8097	19207	8678964
6	7	2530-00-690-2742	19207	8678967
6	7	2530-00-863-5609	19207	8678969
6	8	5320-00-852-1082	19207	8701138
6	9	2530-00-863-5607	19207	5304063
6	10	5315-00-352-1909	33116	22377
6	11	1015-00-087-2833	19207	5304070
6	12	5305-00-269-3236	96906	MS90727-60
6	13	2530-00-737-7747	19207	7377747
6	13	2530-00-737-7748	19207	7377748
6	14	5315-00-839-5820	96906	MS24665-134
6	15	5310-00-584-5272	96906	MS35338-48
6	16	5310-00-732-0560	96906	MS51968-14
6	17	5310-00-637-9541	96906	MS35338-46
6	18	5310-00-732-0559	96906	MS51968-8
7	1	5310-00-880-7745	96906	MS51968-11
7	2	5310-00-209-0965	96906	MS35338-47
7	3	5315-01-054-5870	94189	10959
7	4	2530-01-054-2905	94189	24636
7	5	5315-01-056-3053	94189	14886
7	6	5305-00-709-8517	96906	MS90727-85
7	7	2530-01-054-1509	14894	308430-L
7	7	3040-01-054-2765	94189	16092
7	8	2530-01-264-0505	94189	10961
7	9	2530-01-052-6019	94189	10953
7	10		94189	9795
7	11		94189	9789
7	12	5360-01-180-2292	94189	10960
7	13	2530-01-058-7486	94189	10954
7	14	5360-00-664-5344	19207	5303469
7	15	5360-00-930-5644	06853	39244
7	16	2530-01-054-3918	94189	16756
7	17	5360-01-054-5023	94189	10958
7	18	2530-01-052-5238	94189	10952
7	19	5340-01-087-9679	94189	9254
8	1	5305-00-269-3248	96906	MS90727-72
8	2	5365-01-053-6898	93072	1841
8	3	2530-01-050-8929	93072	10614
8	4		19207	12331725-2
8	5	5330-00-953-1886	80205	NAS1611-128
8	6	5310-00-959-1488	96906	MS51922-21
8	7	5305-01-179-2304	94189	9778
8	8	2530-00-161-7575	94189	9776
8	8	2530-00-161-7576	94189	9777
9	1	4730-00-014-2431	12204	142431
9	2	5305-00-855-0958	96906	MS24629-45
9	3	5340-00-778-2738	96906	MS21333-2

CROSS-REFERENCE INDEXES

FIG	ITEM	FIGURE AND ITEM NUMBER INDEX		PART NUMBER
		STOCK NUMBER	CAGEC	
9	4		19207	11625494
9	5		19207	11625493
9	6	4730-01-123-3802	96906	MS51877-3
9	7	5305-00-984-6208	96906	MS35206-261
9	8	4730-01-043-3055	79470	7805
9	9	5310-00-809-4058	96906	MS27183-10
9	10	5310-00-582-5965	96906	MS35338-44
9	11	5310-00-761-6882	96906	MS51967-2
9	12		19207	11625492-2
9	13		19207	11625492-1
9	14	4720-01-043-5222	19207	11625495
9	15	5330-01-044-1941	19207	11625497
9	16	5340-00-371-4134	19207	11625505
10	1	2530-00-863-5599	71770	FMC8372
10	2	5306-00-850-7069	33116	X43436
10	3	5330-00-678-1759	80201	516992
10	4	3110-00-727-6901	19207	8762093
10	5	3110-00-678-1862	19207	7536132
10	6	3040-00-404-0750	19207	10924603
10	7	5310-00-769-6521	19207	7696521
10	8		21450	7371106
10	9	2530-00-350-8707	96906	MS53069-1
10	10	2530-00-150-7832	19207	12301157
10	11		33116	X-43438
10	12	5310-00-769-6520	19207	7696520
11	1	5330-01-055-3870	94189	15529
11	2	3110-00-763-0259	60038	L68149
11	3	3110-00-769-1426	60038	L68111
11	4	2530-01-052-2895	94189	18147
11	5	5306-01-054-9238	94189	14771
11	6	3110-00-926-1379	60038	L44649
11	7	3110-00-827-8648	60038	L44610
11	8	5310-00-809-8533	96906	MS27183-23
11	9	5310-00-850-6993	96906	MS35692-62
11	10	5315-00-012-0123	96906	MS24665-355
11	11	5340-00-253-1910	94189	14286
11	12	2530-00-150-7832	19207	10921860
11	13	5310-00-177-1329	19207	11630595
12	1	2610-00-678-1363	19207	7342996
12	2	2610-00-350-9975	81348	ZZ-I-550/GP2/6.0 0-16/TR15/OFFCTR
12	3	2640-00-060-3550	51665	US48
12	4	2640-00-050-1229	17875	100AA
13	1		23040	360403S7A1
13	2	4010-00-863-5601	71770	FMC8317
13	3	4730-00-289-5176	02951	MS49005-8
13	4	5315-00-045-4217	19207	7001417
13	5	5360-00-663-3110	94833	73-1438
13	6	4730-00-050-4208	96906	MS15003-1
13	7	5310-00-732-8312	19207	7328312
13	8	5360-00-200-7022	75828	EL53241-1

CROSS-REFERENCE INDEXES

FIG	ITEM	FIGURE AND ITEM NUMBER INDEX		PART NUMBER
		STOCK NUMBER	CAGEC	
13	9	5310-00-732-8314	19207	7328314
13	10	5310-01-213-9952	19207	MS35692-1426
13	11		96906	MS20665-425
13	12		96906	MS20365-820C
13	13	5305-00-709-8517	96906	MS90727-85
13	14		19207	595444
13	15		19207	428829
13	16	5340-00-781-6308	19207	10924577
13	17	2540-00-732-8311	19207	7328311
14	1	5310-00-832-9719	96906	MS51922-61
14	2	5305-00-709-8517	96906	MS90727-85
14	3		19207	10924587-1
14	3		19207	10924587-2
14	4	5310-00-057-7080	96906	MS51922-29
14	5	5310-00-732-0560	96906	MS51968-14
14	6	5310-00-584-5272	96906	MS35338-48
14	7	5305-00-226-7767	96906	MS90726-109
14	8		19207	10924595
14	9	5305-00-728-5475	96906	MS90727-200
15	1	2540-01-271-0272	19207	11625487
15	2	4010-01-158-6795	19207	12296386
15	3	2530-01-053-2453	19207	11625498
15	4	5310-00-877-5795	96906	MS21044N8
15	5	2540-01-051-6355	93072	1808-1
15	6	3120-01-052-1151	93072	1745
15	7	2540-01-051-6354	93072	1829
15	8	5310-00-959-1488	96906	MS51922-21
15	9	5310-00-057-7080	96906	MS51922-29
15	10	2590-01-185-0168	93072	10603
15	11		19207	11625500
15	12	5305-00-709-8423	96906	MS90727-97
15	13	5305-00-269-3248	96906	MS90727-72
15	14	5340-01-257-3883	19207	11625499
15	15	5360-00-663-3110	19207	7328310
15	16	5315-00-045-4217	19207	7001417
15	17	2540-01-050-7136	93072	1844-2
15	18		93072	1855
15	19	2540-01-060-7031	93072	10632
15	20		93072	1756
15	21	2530-01-050-7700	93072	10607
15	22	2530-01-050-8832	93072	1840
15	23	5360-01-054-2281	93072	1828
15	24	4730-00-289-5176	02951	MS49005-8
15	25	2530-01-050-7698	93072	1804
16	1	5305-00-725-4187	96906	MS90726-114
16	2	4730-00-050-4208	96906	MS15003-1
16	3	5310-00-877-5795	96906	MS21044N8
16	4	5340-00-937-1962	19207	10924578
16	5	2510-00-734-3007	19207	7343007
16	6	5305-00-728-5474	96906	MS90727-193
16	7	5310-00-877-5795	96906	MS21044N8

CROSS-REFERENCE INDEXES

FIG	ITEM	FIGURE AND ITEM NUMBER INDEX		PART NUMBER
		STOCK NUMBER	CAGEC	
16	8	5305-00-725-4187	96906	MS90726-114
16	9	5310-00-832-9719	96906	MS51922-61
17	1	5306-00-050-1238	96906	MS90727-32
17	2	5310-00-407-9566	96906	MS35338-45
17	3	5310-00-880-7746	96906	MS51968-5
17	4	5340-01-132-4274	19207	7328987
17	5	5306-01-282-8180	19207	7328295-1
17	6	4730-00-050-4208	96906	MS15003-1
17	7	5340-00-732-8324	19207	7328324
17	8	5305-00-269-2803	96906	MS90726-60
17	9	3040-01-154-1433	19207	10924593
17	10	2510-00-773-5833	23040	GPW5779
17	10	5306-00-737-1090	19207	7371090
17	11	5330-00-732-8322	03677	7328322
17	12	5365-00-732-8323	19207	7328323
17	13	2510-01-058-7420	19207	11669331
17	14	5310-00-732-0559	96906	MS51968-8
17	15	5310-00-637-9541	96906	MS35338-46
17	16	5315-00-839-5822	96906	MS24665-353
17	17	5310-00-850-6884	96906	MS35692-45
17	18	4730-00-206-1384	19207	7328328
17	19	2510-00-769-7598	22852	801244
18	1	5305-00-269-2803	96906	MS90726-60
18	2	5340-01-132-0889	19207	10924584
18	3	5365-00-734-3032	19207	7343032
18	4	5310-00-823-8803	96906	MS27183-21
18	5	5315-00-059-0206	96906	MS24665-491
18	6	2540-00-769-7442	76445	18459
18	7	2510-00-734-3076	23040	GPW5459
18	7	2510-00-769-7848	19207	7697848
18	8	5310-00-209-0965	96906	MS35338-47
18	9	5310-00-732-8296	19207	7328296
18	10	5310-00-732-0559	96906	MS51968-8
18	11	5310-00-637-9541	96906	MS35338-46
19	1	5305-00-115-9526	96906	MS18154-58
19	2	5310-00-080-6004	96906	MS27183-14
19	3	2510-00-774-0886	19207	10924564
19	4	5310-00-637-9541	96906	MS35338-46
19	5	5310-00-732-0559	96906	MS51968-8
20	1	2590-00-705-8970	19207	7328340
20	2	5310-00-596-7691	96906	MS35335-32
20	3	5305-00-990-6444	96906	MS35207-261
20	4	4820-00-732-8336	19207	7328336
21	1	2540-00-863-5598	19207	10913205
21	2	2510-01-111-7096	19207	10924559
21	3	5305-01-140-9118	96906	MS90728-59
21	4	5310-00-080-6004	96906	MS27183-14
21	5	5310-00-637-9541	96906	MS35338-46
21	6	5310-00-732-0559	96906	MS51968-8
22	1	9905-00-205-2795	96906	MS35387-1
22	2	5310-00-732-0559	96906	MS51968-8

CROSS-REFERENCE INDEXES

FIG	ITEM	FIGURE AND ITEM NUMBER INDEX		PART NUMBER
		STOCK NUMBER	CAGEC	
22	3	5310-00-582-5965	96906	MS35338-44
22	4	5310-00-732-8316	19207	7328316
22	5	5305-00-993-2463	96906	MS35207-279
23	1	9905-01-115-2313	19207	11625506
23	1	9905-01-205-6010	19207	10924556
23	2		96906	MS20450C96
23	3	9905-00-282-7489	19207	7979373
23	4	5310-00-768-0319	96906	MS51968-2
23	5	5310-00-582-5965	96906	MS35338-44
23	6	5305-00-993-2463	96906	MS35207-279
23	7		19207	10924608
23	7		19207	11625507
23	8	5305-00-855-0958	96906	MS24629-45

APPENDIX G

ILLUSTRATED LIST OF MANUFACTURED ITEMS

Section I. INTRODUCTION

G-1. SCOPE.

a. This appendix includes complete instructions for making items authorized to be manufactured or fabricated.

b. A part number index in alphanumeric order is provided for cross-referencing the part number of the item to be manufactured to the figure which covers fabrication criteria.

c. All bulk materials needed for manufacture of an item are listed by part number or specification number in the manufacturing instructions.

d. All dimensions given in Section II, *Manufacturing Instructions*, are in standard units.

Table G-1. Manufactured Items Part Number Cross-reference Index.

Part Number	Figure Number
11625492-1	G-1
11625492-2	G-2
11625493	G-3
11625494	G-4

Section II. MANUFACTURING INSTRUCTIONS

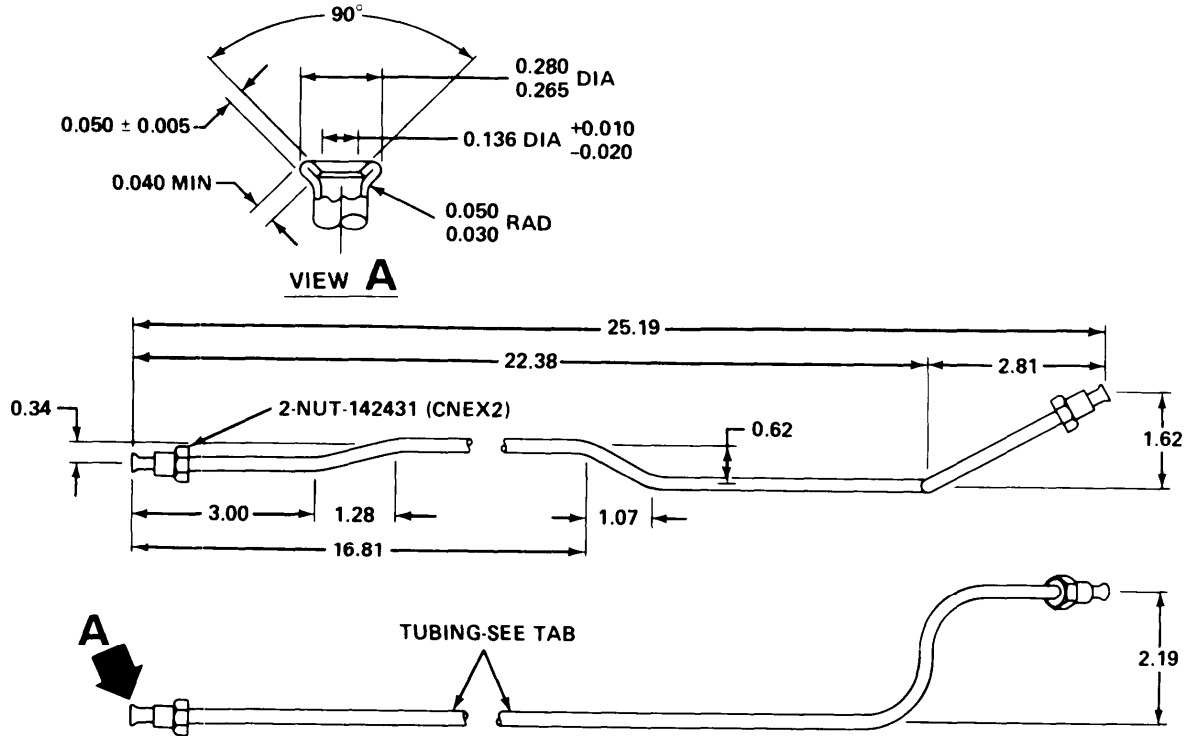

1. Material: tubing, steel, round; 1010 to 1020, Type 1; spec MIL-T-3520; 0.1875 O.D. x 0.025 wall; developed length 60.75 ref.
2. All centerline bend radii to be 1.00.

Figure G-1. Tube, Tee-to-service Brake; Right Side.

Section II. MANUFACTURING INSTRUCTIONS (Con't)

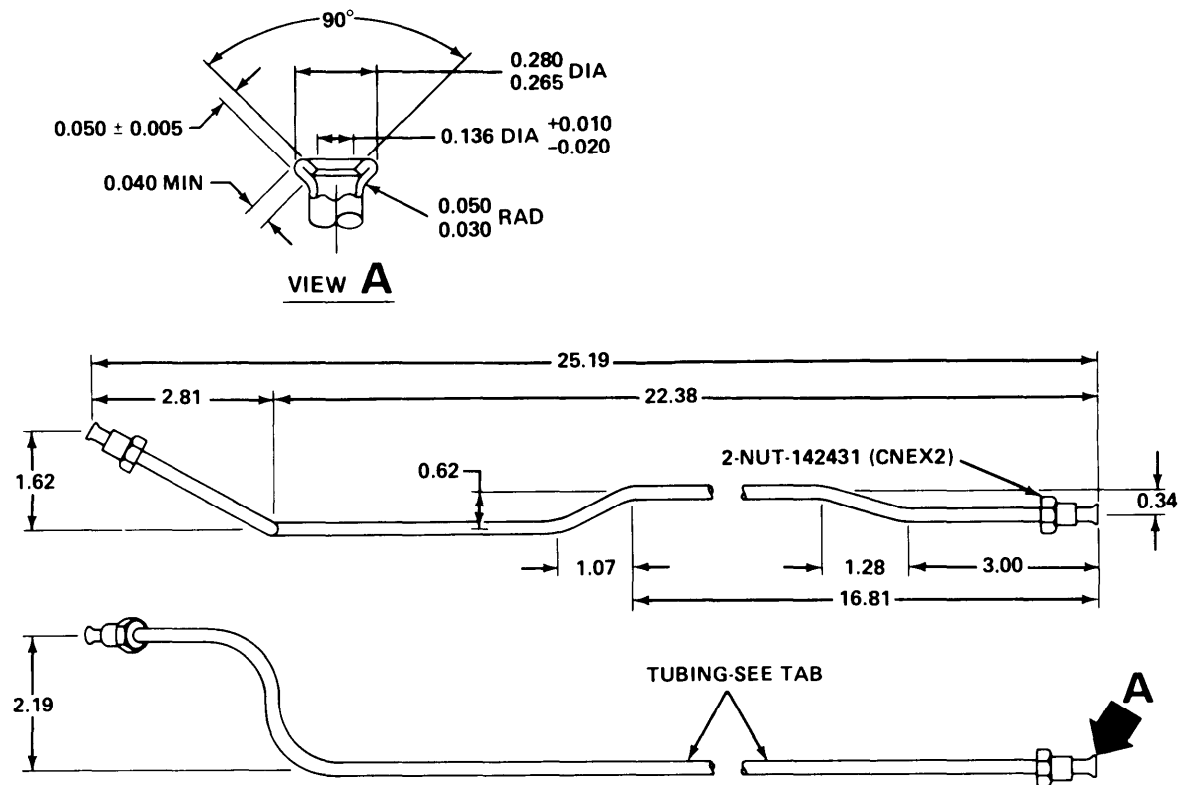

1. Material: tubing, steel, round; 1010 to 1020, Type 1; spec MIL-T-3520; 0.1875 O.D. x 0.025 wall; developed length 60.75 ref.
2. All centerline bend radii to be 1.00.

Figure G-2. Tube, Tee-to-service Brake; Left Side.

Section II. MANUFACTURING INSTRUCTIONS (Con't)

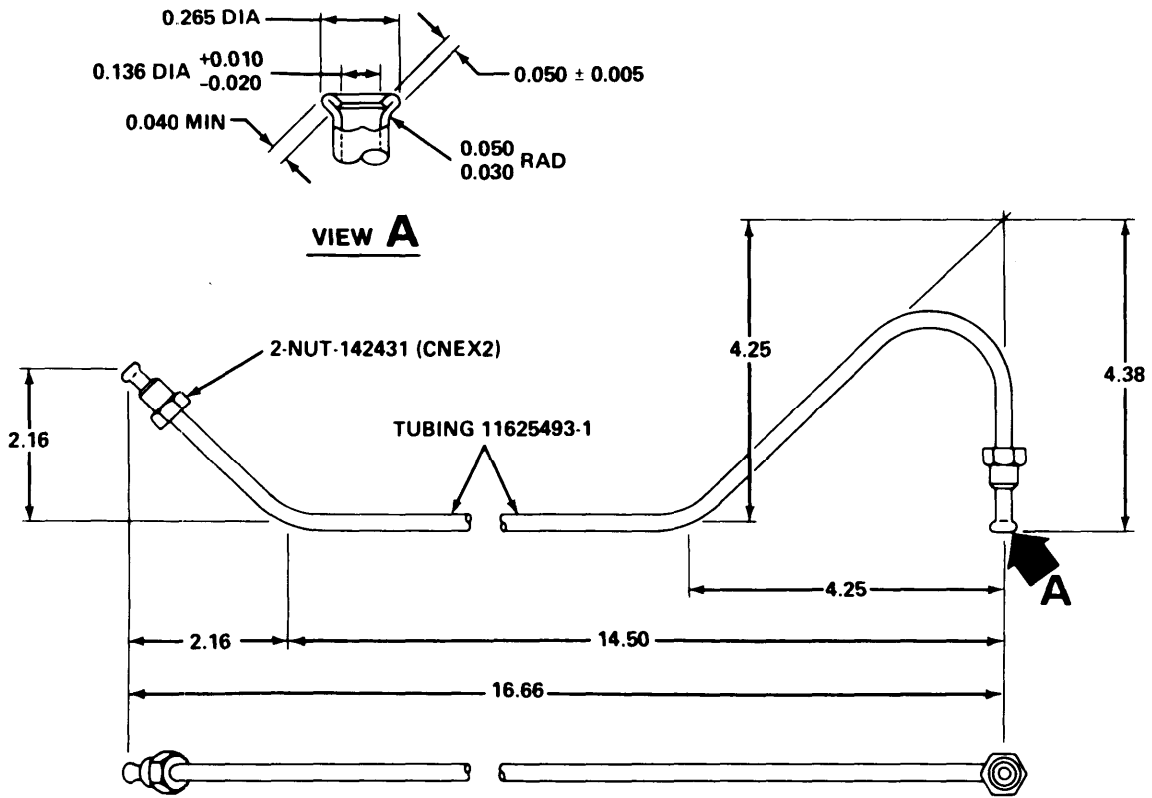

1. Material: tubing, steel, round; 1010 to 1020, Type 1; spec MIL-T-3520; 0.1875 O.D. x 0.025 wall; developed length 60.75 ref.
2. All centerline bend radii to be 1.00.

Figure G-3. Tube, Coupling-to-hose Assembly.

Section II. MANUFACTURING INSTRUCTIONS (Con't)

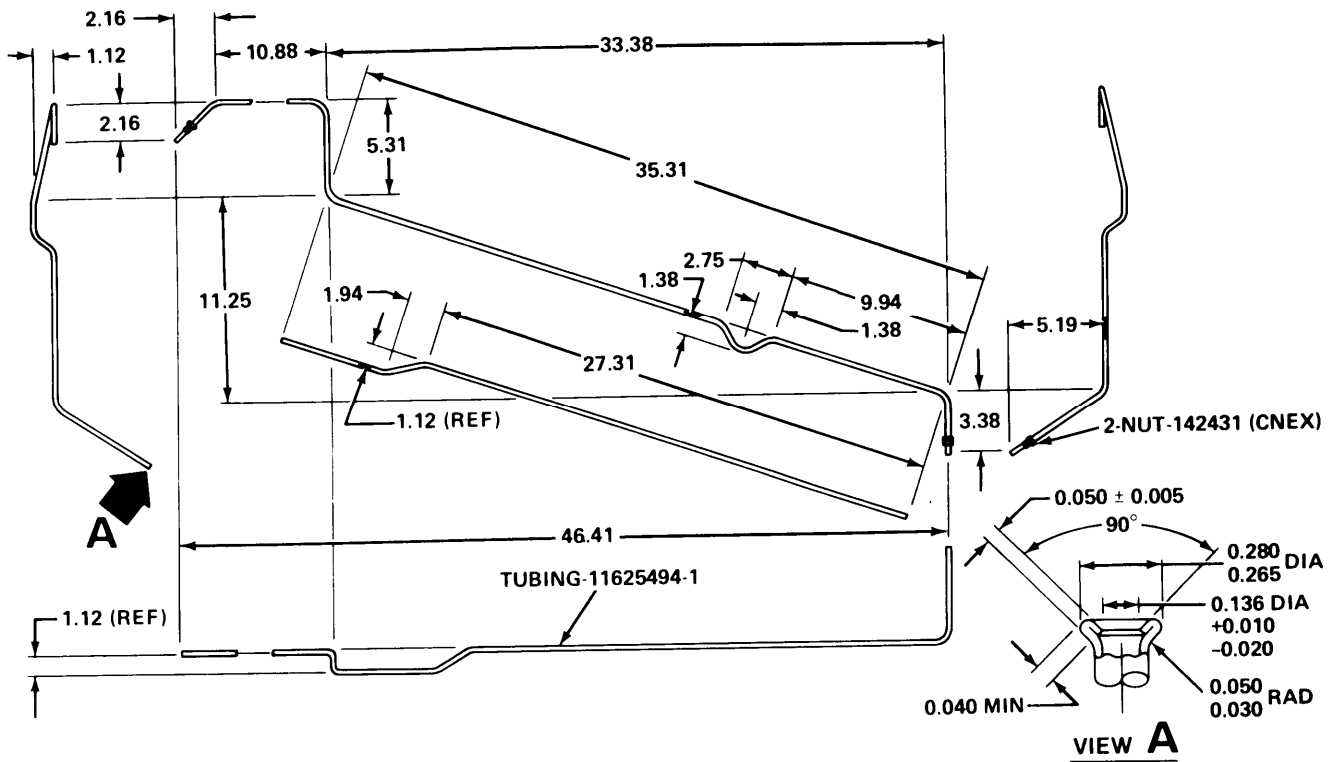

1. Material: tubing, steel, round; 1010 to 1020, Type 1; spec MIL-T-3520; 0.1875 O.D. x 0.025 wall; developed length 60.75 ref.
2. All centerline bend radii to be 1.00.

Figure G-4. Tube, Master Cylinder-to-coupling.

APPENDIX H TORQUE LIMITS

H-1. SCOPE.

This appendix lists standard torque values, as shown in Table H-1, and provides general information for applying torque. Special torque values are indicated in the maintenance procedures for applicable components.





H-2. GENERAL.

- a. Always use the torque values listed below when the maintenance procedure does not give a specific torque value.
- b. Unless otherwise specified, standard torque tolerance shall be +10%.
- c. Torque values are based on clean, dry threads. Reduce torque by 10% when engine oil is used as a lubricant.
- d. Reduce torque by 20% if new plated capscrews are used.
- e. Capscrews threaded into aluminum may require reductions in torque of 30% or more of Grade 5 capscrew torque. Capscrews threaded into aluminum must also attain two capscrew diameters of thread engagement.

CAUTION

If replacement capscrews are of a higher grade than originally supplied, use torque specifications for the original. This will prevent equipment damage due to overtorquing.

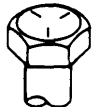
Table H-1. Torque Limits.

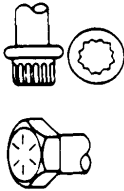
Current Usage	Much Used	Much Used	Used at Times	Used at Times
Quality of Material	Indeterminate	Minimum Commercial	Medium Commercial	Best Commercial
SAE Grade Number Capscrew Head Markings Manufacturer's marks may vary These are all SAE Grade 5 (3 line)	1 or 2  	5 	6 or 7 	8 
Capscrew Body Size inches - Thread	Torque lb.-ft. (N.m)	Torque lb.-ft. (N.m)	Torque lb.-ft. (N.m)	Torque lb.-ft. (N.m)
1/4 20	5 (7)	8 (11)	10 (14)	12 (16)
28	6 (8)	10 (14)		14 (19)
5/16 18	11 (15)	17 (23)	19 (26)	24 (33)
24	13 (18)	19 (26)		27 (37)
3/8 16	18 (24)	31 (42)	34 (46)	44 (60)
24	20 (27)	35 (47)		49 (66)
7/16 14	28 (38)	49 (66)	55 (75)	70 (95)
20	30 (41)	55 (75)		78 (106)
1/2 13	39 (53)	75 (102)	85 (115)	105 (142)
20	41 (56)	85 (115)		120 (163)
9/16 12	51 (69)	110 (149)	120 (163)	155 (210)
18	55 (75)	120 (163)		170 (231)
5/8 11	83 (113)	150 (203)	167 (226)	210 (285)
18	95 (129)	170 (231)		240 (325)
3/4 10	105 (142)	270 (366)	280 (380)	375 (508)
16	115 (156)	295 (400)		420 (569)
7/8 9	160 (217)	395 (536)	440 (597)	605 (820)
14	175 (237)	435 (590)		675 (915)
1 8	235 (319)	590 (800)	660 (895)	910 (1234)
14	250 (339)	660 (895)		990 (1342)

TA503975

INDEX

<i>Subject</i>	<i>Paragraph</i>	<i>Page</i>
A		
Actuator with drawbar coupler (M416A1)	4-40	4-68
Adjustment:		
Brakeshoes:		
M416	4-28	4-39
M416A1	4-29	4-40
Drawbar coupler (M416)	4-41	4-74
Handbrake lever	3-6	3-9
Wheel bearings:		
M416	4-36	4-58
M416A1	4-37	4-62
Axle:		
M416	4-24	4-27
M416A1	4-25	4-29
B		
Bearing, wheel:		
M416	4-36	4-58
M416A1	4-37	4-62
Blackout stoplight (M416)	4-17	4-16
Blackout stoplight lamp (M416)	4-16	4-15
Bleeding hydraulic brake system (M416A1)	4-33	4-49
Body:		
Cargo	4-49	4-87
Repair	5-5	5-5
Brakedrum:		
Maintenance:		
M416	4-36	4-58
M416A1	4-37	4-62
Repair	5-2	5-3
Brakes:		
Brakedrum:		
Maintenance:		
M416	4-36	4-58
M416A1	4-37	4-62
Repair	5-2	5-3
Brakeshoe:		
Adjustment:		
M416	4-28	4-39
M416A1	4-29	4-40

INDEX

<i>Subject</i>	<i>Paragraph</i>	<i>Page</i>
Brakes, Brakeshoe (Con't):		
Repair (M416)	5-1	5-1
Replacement:		
M416	4-30	4-41
M416A1	4-31	4-44
Handbrake:		
Cable assembly	4-27	4-34
Lever:		
Adjustment	3-6	3-9
Replacement	4-26	4-32
Hydraulic brake:		
Lines, hoses, and fittings (M416A1)	4-34	4-51
System bleeding (M416A1)	4-33	4-49
Brakeshoe:		
Adjustment:		
M416	4-28	4-39
M416A1	4-29	4-40
Repair (M416)	5-1	5-1
Replacement:		
M416	4-30	4-41
M416A1	4-31	4-44
Bumper, spring	4-44	4-83

C

Cable:		
Handbrake	4-27	4-34
Intervehicular	4-20	4-20
Cargo body	4-48	4-87
Chain:		
Breakaway:		
Operation	2-2	2-1
Replacement	4-40	4-68
Safety:		
M416	4-41	4-74
M416A1	4-40	4-68
Channel	4-39	4-66
Chassis wiring harness	4-21	4-22
Cleaning instructions, general maintenance	4-12	4-9
Composite light (M416A1)	4-15	4-13
Composite light lamp (M416A1)	4-14	4-11
Controls and indicators, operator's	2-2	2-1

INDEX

<i>Subject</i>	<i>Paragraph</i>	<i>Page</i>
Coupler, drawbar:		
Maintenance (M416)	4-41	4-74
With actuator (M416A1)	4-40	4-68
Coupling trailer to towing vehicle	2-6	2-8
Cylinder:		
Master (M416A1)	4-35	4-57
Wheel (M416A1)	4-32	4-48

D

Data, equipment	1-10	1-7
Destruction of Army materiel to prevent enemy use.	1-3	1-1
Diagrams, wiring	4-23	4-26
Differences between models.	1-8	1-6
Drain valve:		
Operation	2-2	2-1
Replacement	4-47	4-86
Drawbar coupler:		
Actuator with (M416A1)	4-40	4-68
Maintenance (M416)	4-41	4-74
Drum, brake:		
Maintenance:		
M416	4-36	4-58
M416A1	4-37	4-62
Repair	5-2	5-3

E

Enemy use, destruction of Army materiel to prevent	1-3	1-1
Equipment characteristics, capabilities, and features	1-6	1-2
Equipment data	1-10	1-7
Expendable/durable supplies and materials list	Appendix E	E-1

F

Fender:		
Repair	5-5	5-5
Replacement	4-46	4-85
Fittings, hydraulic (M416A1)	4-34	4-51

INDEX

<i>Subject</i>	<i>Paragraph</i>	<i>Page</i>
Fording	2-15	2-12
Frame repair	5-4	5-5

G

General maintenance:		
Cleaning instructions	4-12	4-9
Inspection instructions	4-13	4-10

H

Handbrake:		
Cable assembly	4-27	4-34
Lever:		
Adjustment	3-6	3-9
Replacement	4-26	4-32
Harness:		
Chassis wiring	4-21	4-22
Wiring, repair	4-22	4-24
Hoses, hydraulic (M416A1)	4-34	4-51
Hub:		
M416	4-36	4-58
M416A1	4-37	4-62
Hydraulic:		
Brake lines (M416A1)	4-34	4-51
Brake system bleeding (M416A1)	4-33	4-49
Hoses and fittings (M416A1)	4-34	4-51

I

Identification plates	4-50	4-91
Illustrated list of manufactured items	Appendix G	G-1
Inspection:		
Instructions, general maintenance	4-13	4-10
Preliminary, service upon receipt	4-5	4-2
Intervehicular cable	4-20	4-20

INDEX

<i>Subject</i>	<i>Paragraph</i>	<i>Page</i>
L		
Lamps:		
Blackout stoplight (M416)	4-16	4-15
Composite light (M416A1)	4-14	4-11
Stoplight taillight (M416)	4-18	4-17
Landing leg	4-42	4-77
Leg, landing	4-42	4-77
Lever, handbrake:		
Adjustment	3-6	3-9
Replacement	4-26	4-32
Lights:		
Blackout stoplight (M416)	4-17	4-16
Composite light (M416A1)	4-15	4-13
Stoplight taillight (M416)	4-19	4-18
Stoplight taillight (M416)	4-34	4-51
Lines, hydraulic brake (M416A1)	1-7	1-3
Location and description of major components		
Lubrication:		
Chart		3-3
Instructions under unusual conditions	3-3	3-2
Specific instructions	3-2	3-1

M

Maintenance Allocation Chart (MAC)	Appendix B	B-1
Major components, location and description of	1-7	1-3
Manufactured items, illustrated list of	Appendix G	G-1
Master cylinder (M416A1)	4-35	4-57
Models, differences between	1-8	1-6

O

Oil seal, wheel:		
M416	4-36	4-58
M416A1	4-37	4-62
Operator/crew:		
Preventive Maintenance Checks and Services (PMCS)	Table 2-1	2-6
Troubleshooting	Table 3-1	3-7
Troubleshooting symptom index	3-5	3-7
Operator's controls and indicators	2-2	2-1

INDEX

<i>Subject</i>	<i>Paragraph</i>	<i>Page</i>
Organizational:		
Preventive Maintenance Checks and Services (PMCS)	Table 4-1	4-4
Troubleshooting	Table 4-2	4-6
Troubleshooting symptom index	4-10	4-5
 P 		
Plates:		
Identification	4-50	4-91
Locations and contents of	1-9	1-6
Preparation of equipment for:		
Administrative storage	4-54	4-93
Shipment	4-58	4-96
Preventive Maintenance Checks and Services (PMCS):		
Operator/crew	Table 2-1	2-6
Organizational	Table 4-1	4-4
 R 		
Reflector replacement	4-49	4-90
Repair Parts and Special Tools List (RPSTL)	Appendix F	F-1
 S 		
Safety chains:		
M416	4-41	4-74
M416A1	4-40	4-68
Service upon receipt:		
Preliminary inspection	4-5	4-2
Preliminary service and adjustment	4-6	4-2
Shipment, preparation of equipment for	4-57	4-96
Shock absorber	4-45	4-84
Shoe, brake:		
Adjustment:		
M416	4-28	4-39
M416A1	4-29	4-40
Repair (M416)	5-1	5-1
Replacement:		
M416	4-30	4-41
M416A1	4-31	4-44

INDEX

<i>Subject</i>	<i>Paragraph</i>	<i>Page</i>
Spring:		
Assembly maintenance	4-43	4-78
Bumper	4-44	4-83
Stoplight taillight (M416)	4-19	4-18
Stoplight taillight lamp (M416)	4-18	4-17
Storage, administrative:		
Preparation of equipment for.	4-53	4-93
Removal of equipment from.	4-56	4-96
Symptom index, troubleshooting:		
Operator/crew	3-5	3-7
Organizational	4-10	4-5

T

Taillight, stoplight (M416)	4-19	4-18
Taillight, stoplight lamp (M416)	4-18	4-17
Tires:		
Maintenance	4-38	4-65
Repair	5-3	5-4
Torque limits	Appendix H	H-1
Towing instructions	2-7	2-9
Towing vehicle:		
Coupling trailer to	2-6	2-8
Uncoupling trailer from	2-8	2-10
Troubleshooting:		
Operator/crew	Table 3-1	3-7
Organizational	Table 4-2	4-6
Troubleshooting symptom index:		
Operator/crew	3-5	3-7
Organizational	4-10	4-5
Tubes maintenance	4-38	4-65

U

Uncoupling trailer from towing vehicle	2-8	2-10
--	-----	------

V

Valve, drain	4-47	4-86
--------------------	------	------

INDEX

Subject

Paragraph Page

W

Wheel:		
Bearing maintenance and adjustment:		
M416	4-36	4-58
M416A1	4-37	4-62
Cylinder (M416A1)	4-32	4-48
Hub:		
M416	4-36	4-58
M416A1	4-37	4-62
Oil seal:		
M416	4-36	4-58
M416A1	4-37	4-62
Replacement	3-7	3-10
Tires and tubes	4-38	4-65
Wiring:		
Diagrams	4-23	4-26
Harness, chassis,	4-21	4-22
Wiring harness repair	4-22	4-24

By Order of the Secretary of the Army:

Official:

CARL E. VUONO
General, United States Army
Chief of Staff

THOMAS F. SIKORA
Brigadier General, United States Army
The Adjutant General

Distribution:

To be distributed in accordance with DA Form 12-39-E, Block 0568, Operator, Unit, and Direct Support and General Support maintenance requirements for TM9-2330-251-14&P.

RECOMMENDED CHANGES TO EQUIPMENT TECHNICAL PUBLICATIONS



THEN... JOT DOWN THE DOPE ABOUT IT ON THIS FORM. CAREFULLY TEAR IT OUT. FOLD IT AND DROP IT IN THE MAIL!

SOMETHING WRONG WITH THIS PUBLICATION?

FROM: (PRINT YOUR UNIT'S COMPLETE ADDRESS)

CO. B, 1st Bn. 2d Bde
Ft. Hood, TX 76544

DATE SENT

15 January 1991

PUBLICATION NUMBER

TM 9-2330-251-14&P

PUBLICATION DATE

PUBLICATION TITLE Operator's, Org., DS/GS Maintenance Manual Including RPSTL for M416 Series Trailers

BE EXACT. PIN-POINT WHERE IT IS

PAGE NO	PARA-GRAPH	FIGURE NO	TABLE NO
4-104	4-39a	N/A	N/A

IN THIS SPACE TELL WHAT IS WRONG AND WHAT SHOULD BE DONE ABOUT IT:

Step 8 and 9 cannot be performed as written. The procedure will work if the steps are revised.

SAMPLE

PRINTED NAME, GRADE OR TITLE, AND TELEPHONE NUMBER

John Doe Sp4 632-0639

SIGN HERE

John Doe

DA FORM 2028-2
1 JUL 79

PREVIOUS EDITIONS ARE OBSOLETE.

PS--IF YOUR OUTFIT WANTS TO KNOW ABOUT YOUR RECOMMENDATION MAKE A CARBON COPY OF THIS AND GIVE IT TO YOUR HEADQUARTERS

FILL IN YOUR
UNIT'S ADDRESS

FOLD BACK

DEPARTMENT OF THE ARMY

Co. B, 1st Bn. 2d Bde
Ft. Hood, TX 76544

OFFICIAL BUSINESS

Commander
US Army Tank-Automotive Command
ATTN: AMSTA-MB
Warren, Michigan 48397-5000

SAMPLE

TEAR ALONG PERFORATED LINE

RECOMMENDED CHANGES TO EQUIPMENT TECHNICAL PUBLICATIONS



SOMETHING WRONG WITH THIS PUBLICATION?

THEN... JOT DOWN THE DOPE ABOUT IT ON THIS FORM. CAREFULLY TEAR IT OUT. FOLD IT AND DROP IT IN THE MAIL!

FROM: (PRINT YOUR UNIT'S COMPLETE ADDRESS)

DATE SENT

<p style="font-size: x-small; margin: 0;">PUBLICATION NUMBER</p> <p style="text-align: center; margin: 0;">TM 9-2330-251-14&P</p>	<p style="font-size: x-small; margin: 0;">PUBLICATION DATE</p> <p style="text-align: center; margin: 0;">4 September 1990</p>	<p style="font-size: x-small; margin: 0;">PUBLICATION TITLE</p> <p style="margin: 0;">Operator's, Org., DS/GS Maintenance Manual Including RPSTL for M416 Series Trailers</p>
---	---	---

BE EXACT. PIN-POINT WHERE IT IS				IN THIS SPACE TELL WHAT IS WRONG AND WHAT SHOULD BE DONE ABOUT IT:
PAGE NO	PARA-GRAPH	FIGURE NO	TABLE NO	

PRINTED NAME, GRADE OR TITLE, AND TELEPHONE NUMBER

SIGN HERE

FILL IN YOUR
UNIT'S ADDRESS



FOLD BACK

DEPARTMENT OF THE ARMY



OFFICIAL BUSINESS

Commander
US Army Tank-Automotive Command
ATTN: AMSTA-MB
Warren, Michigan 48397-5000

TEAR ALONG PERFORATED LINE

RECOMMENDED CHANGES TO EQUIPMENT TECHNICAL PUBLICATIONS



THEN... JOT DOWN THE DOPE ABOUT IT ON THIS FORM. CAREFULLY TEAR IT OUT. FOLD IT AND DROP IT IN THE MAIL!

SOMETHING WRONG WITH THIS PUBLICATION?

FROM: (PRINT YOUR UNIT'S COMPLETE ADDRESS)

DATE SENT

PUBLICATION NUMBER
TM 9-2330-251-14&P

PUBLICATION DATE
4 September 1990

PUBLICATION TITLE Operator's, Org., DS/GS
Maintenance Manual Including RPSTL for
M416 Series Trailers

BE EXACT. PIN-POINT WHERE IT IS

PAGE NO	PARA-GRAPH	FIGURE NO	TABLE NO
---------	------------	-----------	----------

IN THIS SPACE TELL WHAT IS WRONG AND WHAT SHOULD BE DONE ABOUT IT:

PRINTED NAME, GRADE OR TITLE, AND TELEPHONE NUMBER

SIGN HERE

FILL IN YOUR
UNIT'S ADDRESS



FOLD BACK

TEAR ALONG PERFORATED LINE

DEPARTMENT OF THE ARMY



OFFICIAL BUSINESS

Commander
US Army Tank-Automotive Command
ATTN: AMSTA-MB
Warren, Michigan 48397-5000

FILL IN YOUR
UNIT'S ADDRESS



FOLD BACK

DEPARTMENT OF THE ARMY

OFFICIAL BUSINESS

TEAR ALONG PERFORATED LINE

Commander
US Army Tank-Automotive Command
ATTN: AMSTA-MB
Warren, Michigan 48397-5000

THE METRIC SYSTEM AND EQUIVALENTS

LINEAR MEASURE

1 Centimeter=10 Millimeters=0.01 Meters=0.3937 Inches
 1 Meter=100 Centimeters=1000 Millimeters=39.37 Inches
 1 Kilometer=1000 Meters=0.621 Miles

WEIGHTS

1 Gram=0.001 Kilograms=1000 Milligrams=0.035 Ounces
 1 Kilogram=1000 Grams=2.2 Lb
 1 Metric Ton=1000 Kilograms=1 Megagram=1.1 Short Tons

LIQUID MEASURE

1 Milliliter=0.001 Liters=0.0338 Fluid Ounces
 1 Liter=1000 Milliliters=33.82 Fluid Ounces

SQUARE MEASURE

1 Sq Centimeter=100 Sq Millimeters=0.155 Sq Inches
 1 Sq Meter=10,000 Sq Centimeters=10.76 Sq Feet
 1 Sq Kilometer=1,000,000 Sq Meters=0.386 Sq Miles

CUBIC MEASURE

1 Cu Centimeter=1000 Cu Millimeters=0.06 Cu Inches
 1 Cu Meter=1,000,000 Cu Centimeters=35.31 Cu Feet

TEMPERATURE

5/9 (°F - 32) = °C
 212° Fahrenheit is equivalent to 100° Celsius
 90° Fahrenheit is equivalent to 32.2° Celsius
 32° Fahrenheit is equivalent to 0° Celsius
 9/5 C° + 32 = F°

APPROXIMATE CONVERSION FACTORS

<u>TO CHANGE</u>	<u>TO</u>	<u>MULTIPLY BY</u>
Inches	Centimeters	2.540
Feet	Meters	0.305
Yards	Meters	0.914
Miles	Kilometers	1.609
Square Inches	Square Centimeters	6.451
Square Feet	Square Meters	0.093
Square Yards	Square Meters	0.836
Square Miles	Square Kilometers	2.590
Acres	Square Hectometers	0.405
Cubic Feet	Cubic Meters	0.028
Cubic Yards	Cubic Meters	0.765
Fluid Ounces	Milliliters	29.573
Pints	Liters	0.473
Quarts	Liters	0.946
Gallons	Liters	3.785
Ounces	Grams	28.349
Pounds	Kilograms	0.454
Short Tons	Metric Tons	0.907
Pound-Feet	Newton-Meters	1.356
Pounds per Square Inch	Kilopascals	6.895
Miles per Gallon	Kilometers per Liter	0.425
Miles per Hour	Kilometers per Hour	1.609

<u>TO CHANGE</u>	<u>TO</u>	<u>MULTIPLY BY</u>
Centimeters	Inches	0.394
Meters	Feet	3.280
Meters	Yards	1.094
Kilometers	Miles	0.621
Square Centimeters	Square Inches	0.155
Square Meters	Square Feet	10.764
Square Meters	Square Yards	1.196
Square Kilometers	Square Miles	0.386
Square Hectometers	Acres	2.471
Cubic Meters	Cubic Feet	35.315
Cubic Meters	Cubic Yards	1.308
Milliliters	Fluid Ounces	0.034
Liters	Pints	2.113
Liters	Quarts	1.057
Liters	Gallons	0.264
Grams	Ounces	0.035
Kilograms	Pounds	2.205
Metric Tons	Short Tons	1.102
Newton-Meters	Pound-Feet	0.738
Kilopascals	Pounds per Square Inch	0.145
Kilometers per Liter	Miles per Gallon	2.354
Kilometers per Hour	Miles per Hour	0.621

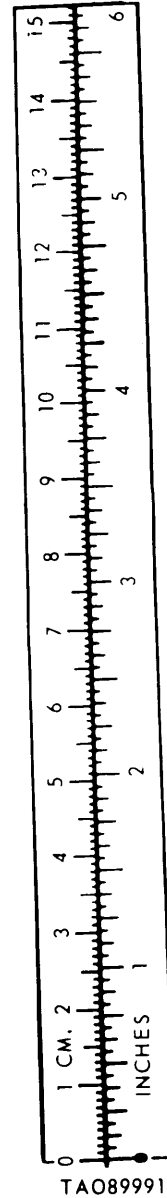

FOR REFERENCE ONLY

