

ARMY TECHNICAL MANUAL

TM 5-6115-323-24P

AIR FORCE TECHNICAL ORDER

T.O.35C2-3-385-4

MARINE CORPS STOCK LIST

SL4-07609A/07610A

TECHNICAL MANUAL

**ORGANIZATIONAL, INTERMEDIATE (FIELD)
(DIRECT SUPPORT AND GENERAL SUPPORT)
AND DEPOT MAINTENANCE REPAIR PARTS
AND SPECIAL TOOLS LIST**

**GENERATOR SET, GASOLINE ENGINE DRIVEN,
SKID MOUNTED, TUBULAR FRAME, 1.5 KW,
SINGLE PHASE, AC, 120/240 VOLTS,
28 VDC (LESS ENGINE)**

DOD MODELS

MEP-015A

MEP-025A

Hertz

60

28 VDC

NSN

6115-00-889-1446

6115-00-017-8236

*This manual supersedes TM 5-6115-323-24P, 30 September 1975, including all changes.

**PUBLISHED UNDER THE AUTHORITY OF THE DEPARTMENTS OF THE
ARMY, AIR FORCE, AND U.S. MARINE CORPS**

1 MAY 1986

TM 5-6115-323-24P
T.O. 35C2-3-385-4
SL 4-07609A7610A
C4

CHANGE

HEADQUARTERS, DEPARTMENTS OF
THE ARMY, AIR FORCE AND
HEADQUARTERS, U.S. MARINE CORPS
WASHINGTON, D.C., 3 March 1997

NO. 4

**ORGANIZATIONAL INTERMEDIATE (FIELD) (DIRECT SUPPORT
AND GENERAL SUPPORT) AND DEPOT MAINTENANCE
REPAIR PARTS AND SPECIAL TOOLS LIST**

**GENERATOR SET, GASOLINE ENGINE DRIVEN, SKID
MOUNTED, TUBULAR FRAME, 15 KW, SINGLE PHASE,
AC, 120/240 VOLTS, 28 VDC (LESS ENGINE)**

DOD MODELS

HERTZ

NSN

MEP-015A
MEP-025A

60
28 VDC

6115-0-889-1446
6115-00-017-8236

DISTRIBUTION STATEMENT A: Approved for public release; distribution is unlimited.

TM 5-6115-323-24P/T.O. 35C2-3-385-4/SL4-07609A/0761 OA, 1 May 1986, is changed as follows:

1. Remove and insert pages as indicated below. New or changed text material is indicated by a vertical bar in the margin. An illustration change is indicated by a miniature pointing hand.

Remove pages
i/(ii blank)
7 and 8
33 and 34

Insert pages
i/(ii blank)
7 and 8
33 and 34

2. Retain this sheet in front of manual for reference purposes.

TM 5-6115323-24P
T.O. 35C2-4-385-4
SL4 07609A07610A
C4

By Order of the Secretaries of the Army, Air Force, and Navy (Including the Marine Corps):

Official: 

JOEL B. HUDSON
*Administrative Assistant to the
Secretary of the Army*
03173

DENNIS J. REIMER
*General, United States Army
Chief of Staff*

RONALD R. FOGELMAN
*General, USAF
Chief of Staff*

HENRY VICCELLIO, JR.
*General, USAF
Commander, Air Force Materiel Command*

J. E. BUFFINGTON
*Rear Admiral, CEC, US Navy
Commander
Navy Facilities Engineering
Command*

M. K. HAYDEN
*Colonel, USMC
Director, Program Support
Maine Corps Systems Command*

DISTRIBUTION:

To be distributed in accordance with DA Form 12-25-E, block no. 0875, requirements for TM 5-6115-323-24P.

CHANGE

HEADQUARTERS
DEPARTMENTS OF THE ARMY, AIR FORCE,
AND HEADQUARTERS U.S.MARINE CORPS
WASHINGTON, D.C., 15 DECEMBER 1992

NO. 3

Organizational, Intermediate (Field)
(Direct Support and General Support)
And Depot Maintenance Repair Parts
And Special Tools List

**GENERATOR SET, GASOLINE ENGINE DRIVEN,
SKID MOUNTED, TUBULAR FRAME, 1.5 kW,
SINGLE PHASE, AC, 120/240 VOLTS,
28 VDC (LESS ENGINE)**

DOD MODELS	HERTZ	NSN
MEP-015A	60	6115-00-889-1446
MEP-025A	28 VDC	6115-00-017-8236

Approved for public release; Distribution is unlimited

TM 5-6115-323-24P/T.O. 35C2-3-385-4/SL4-07609A/07610A, 1 May 1986 is changed as follows:

1. Remove and insert pages as indicated below. New or changed text material is indicated by a vertical bar in the margin. An illustration change is indicated by a miniature pointing hand.

Remove pages

3 and 4
7 and 8
33 and 34
37 through 40

Insert pages

3 and 4
7 and 8
33 and 34
37 through 40

2. Retain this sheet in front of manual for reference purposes.

TM 5-6115-323-24P
T.O. 35C2-3-385-4
SL4-07609A/07610A
C3

By Order of the Secretaries of the Army, Air Force, and Navy (Including the Marine Corps):

Official:

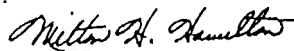

MILTON H. HAMILTON
*Administrative Assistant to the
Secretary of the Army*

03069

GORDON R. SULLIVAN
*General, United States Army
Chief of Staff*

MERRILL A. McPEAK
*General, USAF
Chief of Staff*

Official:

RONALD W. YATES
*General, United States Air Force
Commander, Air Force Materiel Command*

DAVID E. BOTTORFF
*Rear Admiral, CEC, US Navy
Commander
Navy Facilities Engineering Command*

RONALD D. ELLIOTT
*Executive Director
Marine Corps Systems Command*

DISTRIBUTION:

To be distributed in accordance with DA Form 12-25-E, block no. 0875, requirements for
TM 5-6115-323-24P.

CHANGE

HEADQUARTERS,
DEPARTMENTS OF THE ARMY, AIR FORCE
AND HEADQUARTERS U.S. MARINE CORPS
WASHINGTON, D.C., 27 November 1990

NO. 2

Organizational, Intermediate (Field)
(Direct Support And General Support)
And Depot Maintenance Repair Parts
And Special Tools List

GENERATOR SET, GASOLINE ENGINE DRIVEN,
SKID MOUNTED, TUBULAR FRAME, 1.5 KW,
SINGLE PHASE, AC, 120/240 VOLTS,
28 VDC (LESS ENGINE)

DOD MODELS	HERTZ	NSN
MEP-015A	60	6115-00-889-1446
MEP-025A	28 VDC	6115-00-017-8236

Approved for public release; distribution is unlimited

TM 5-6115-323- 24P/T. O. 35C2-3-385-4/SL4-07609A/07610A, 1 May 1986, is changed as follows.

1. Remove and insert pages as indicated below. New or changed text material is indicated by a vertical bar in the margin. An illustration change is indicated by a miniature pointing hand.

Remove pages	Insert pages
i/ii	i/ii
7 and 8	7 and 8
11 through 14	11 through 14
20	20
21 and 22	21 and 22
33 through 38	33 through 38

2. Retain this sheet in front of manual for reference purposes.

TM 5-6115-323-24P
T.O. 35C2-3-385-4
SL4-07609A/07610A
C2

By Order of the Secretaries of the Army, the Navy, and Air Force (Including the Marine Corps):

CARL E. VUONO
General, United States Army
Chief of Staff

Official:

THOMAS F. SIKORA
Brigadier General, United States Army
The Adjutant General

B. F. MONTOYA
Rear Admiral, CEC, US Navy
Commander
Naval Facilities Engineering Command

LARRY D. WELCH,
General USAF
Chief of Staff

Official:

ALFRED G. HANSEN
General, USAF, Commander, Air Force
Logistics Command

B.F. MONTOYA
Rear Admiral, CEC, US Navy
Commander
Navy Facilities Engineering Command

H.E. REESE
Executive Director
Marine Corps Research, Development and
Acquisition Command

DISTRIBUTION:

To be distributed in accordance with DA Form 12-25E, (qty rqr block no. 0675).

CHANGE }
No. 1 }

HEADQUARTERS, DEPARTMENTS OF THE ARMY AND AIR
FORCE AND HEADQUARTERS, U.S. MARINE CORPS
WASHINGTON, D.C., 17 March 1989

ORGANIZATIONAL, INTERMEDIATE (FIELD)
(DIRECT SUPPORT AND GENERAL SUPPORT)
AND DEPOT MAINTENANCE REPAIR PARTS
AND SPECIAL TOOLS LIST

GENERATOR SET, GASOLINE ENGINE DRIVEN,
SKID MOUNTED, TUBULAR FRAME, 1.5 KW,
SINGLE PHASE, AC, 120/240 VOLTS,
28 VDC (LESS ENGINE)

DOD MODELS	HERTZ	NSN
MEP-015A	60	6115-00-889-1446
MEP-025A	28 VDC	6115-00-017-8236

Approved for public release. Distribution is unlimited.

TM 5-6115-323-23P/T.O. 35C2-3-385-4/SL4-07609A/07610A, 1 May 1986, is changed as follows:

1. Remove and insert pages as indicated below. New or changed text material is indicated by a vertical bar in the margin. An illustration change is indicated by a miniature pointing hand.

Remove pages	Insert pages
2 through 8	2 through 8
11 and 12	11 and 12
15 and 16	15 and 16
---	16.1/16.2
28	28
29 and 30	29 and 30
---	30.2
31 through 40	31 through 40

2. Retain this sheet in front of manual for reference.

TM 5-6115-323-24P
T.O. 35C2-3-385-4
SL4-07609A/07610A
C 1

By Order of the Secretaries of the Army, Air Force and Navy (Including the Marine Corps):

CARL E. VUONO
General, United States Army
Chief of Staff

Official:

WILLIAM J. MEEHAN, II
Brigadier General, United States Army
The Adjutant General

B. F. MONTOYA
Rear Admiral, CEC, US Navy
Commander
Naval Facilities Engineering Command

LARRY D. WELCH , General USAF
Chief of Staff

Official:

ALFRED G. HANSEN
General, USAF, Commander, Air Force
Logistics Command

H. E. REESE
Executive Director
Marine Corps Research, Development and
Acquisition Command

To be distributed in accordance with DA Form 12-25A, Unit, Direct Support and General Support Maintenance Requirements for Generator Set, Gas Driven, Skid Mounted, 120/240V, AC, 28V DC, 1.5KW, 1PH (60HZ AC: MEP-015A; 60HZ DC MEP-025A).

TECHNICAL MANUAL

HEADQUARTERS
DEPARTMENTS OF THE ARMY, AIR FORCE
AND U.S. MARINE CORPS
WASHINGTON, D.C., 1 May 1986

NO. 5-6115-323-24P

ORGANIZATIONAL, INTERMEDIATE (FIELD) (DIRECT SUPPORT, AND GENERAL SUPPORT)
AND DEPOT MAINTENANCE REPAIR PARTS AND SPECIAL TOOLS LIST

**GENERATOR SET, GASOLINE ENGINE DRIVEN, SKID
MOUNTED, TUBULAR FRAME, 1.5 KW, SINGLE PHASE,
AC, 120/240 VOLTS, 28 VDC (LESS ENGINE)**

DOD MODELS	HERTZ	NSN
MEP-01 5A	60	6115-00-889-1446
MEP-025A	28 VDC	6115-00-017-8236

Current as of 30 OCTOBER 1984

REPORTING ERRORS AND RECOMMENDING IMPROVEMENTS

You can help improve this manual. If you find any mistakes, or if you know of a way to improve these procedures, please let us know. Mail your letter or DA Form 2028 (Recommended Changes to Publications and Blank Forms), or DA Form 2028-2 located in the back of this manual directly to: Commander, US Army Aviation and Troop Command, ATTN: AMSAT-I-MP, 4300 Good fellow Blvd., St. Louis, MO 63120-1798. You may also submit your recommended changes by E-mail directly to <mpmtYoavma28@st-louis-emh7.army.mil>. A reply will be furnished directly to you. Instructions for sending an electronic 2028 may be found at the back of this manual immediately preceding the hard copy 2028.

DISTRIBUTION STATEMENT A: Approved for public release; distribution is unlimited.

TABLE OF CONTENTS

		Page	Illus. Figure
Section VI.	Introduction	iii	
VII.	Repair Parts	3	
Group 01.	Engine assembly.....	3	1
02	Frame assembly	5	2
03	Fuel system.....	7	3
04	Control box assembly.....	11	
	Control box mounting.....	10	4
	Box assembly, 60 Hz	12	5
	Wiring Harness, 60 Hz	16	6
	Box assembly, 28 Volt, DC	20	7
	Wiring harness, 28 Volt DC.....	24	8
Group 05	Generator assembly, 60 Hz	29	9
	Generator assembly, 28 Volts, DC.....	32	10
06	Bulk material	33	
Section VIII.	Special tools list (Not applicable)		
Section IX.	National stock number and part number index	34	
Section X.	Reference designator index (not applicable)		

Change 4 i/(ii blank)

SECTION I INTRODUCTION

1. SCOPE.

This joint Army, Air Force and Marine Corps manual lists repair parts and special tools, required for the performance of organizational, intermediate (field), direct and general support and depot maintenance of the Generator set. The following paragraphs are keyed to applicable users. All users should read paragraph 4, Special Information prior to using this manual.

2. GENERAL

This Repair Parts and Special Tools List is divided into the following sections:

a. (ALL) Repair Parts - Section II. A list of repair parts is authorized for the performance of maintenance at the organizational, intermediate (field), direct support, general support and depot level in figure and item number sequence.

b. (ALL) Special Tools, Test and Support Equipment - Section III (Not applicable).

c. National Stock Number and Reference Number Index - Section IV. A list of National Stock Numbers in ascending numerical sequence followed by a list of reference numbers appearing in all the listings, in ascending alpha-numeric sequence, cross-referenced to the illustration figure number and items number.

d. Reference Designators Index - Section V (Not applicable).

3. EXPLANATION OF COLUMNS

The following provides an explanation of columns in the tabular lists in Sections II and III.

a. (ALL) Illustration. (Column 1) this column is divided as follows:

(1) Figure number. (Column 1a) indicates the figure number of the illustration on which the item is shown.

(2) Item number. (Column 1b) indicates the number used to identify the item on the illustration.

b. (ALL) **Source, Maintenance, and Recoverability Codes (SMR), (Column 2).**

(1) Uniform Source Codes applicable to all Military Services. GENERAL:
Source codes are assigned to support items to indicate the manner of acquiring support items for maintenance, repair, or overhaul of end items. Source codes **are** entered in the first and second positions of the Uniform SMR Code format as follows

Code	Definition
PA	Item procured and stocked for anticipated or known usage.
PB	Item procured and stocked for insurance purposes because essentiality dictates that a minimum quantity be available in the supply system.
PC	Item procured and stocked and which otherwise would be coded PA except that it is deteriorative in nature. Support item, excluding support equipment, procured for initial issue or outfitting and stocked only for subsequent or additional initial issues or outfittings. Not subject to automatic replenishment.

Code	Definition
PD	Support item, excluding support equipment procured for initial issue or outfitting and stocked only for subsequent or additional initial issues or outfittings. Not subject to automatic replenishment.
PE	Support equipment procured and stocked for initial issue or outfittings to specified maintenance repair activities.
PF	Support equipment which will not be stocked but which will be centrally procured on demand.
PG	Item procured and stocked to provide for sustained support for the life of the equipment. It is applied to an item peculiar to the equipment which because of probable discontinuance or shutdown of production facilities would prove uneconomical to reproduce at a later time.
KD	An item of depot overhaul/repair kit and not purchased separately. Depot kit defined as a kit that provides items required at the time of overhaul or repair.
KF	An item of a maintenance kit and not purchased separately. Maintenance kit is defined as a kit that provides an item that can be replaced at organizational or intermediate levels of maintenance.
KB	Item included in both a depot overhaul/repair kit and a Maintenance kit.
MO	Item to be manufactured or fabricated at organizational level.
MF	Item to be manufactured or fabricated at intermediate maintenance levels. Air Force - Intermediate (*) Army - Direct Support (*) Marine Corps - 3rd Echelon
MH	Item to be manufactured or fabricated at intermediate maintenance levels. Air Force - Intermediate (*) Army - General Support (*) Marines Corps - 4th Echelon
MD	Item to be manufactured or fabricated at depot maintenance level.
AO	Item to be assembled at organizational level.
AF	Item to be assembled at intermediate maintenance levels. Air Force - Intermediate (*) Army - Direct Support (*) Marine Corps - 3rd Echelon
AH	Item to be assembled at intermediate maintenance levels. Air Force - Intermediate (*) Army - General Support (*) Marine Corps - 4th Echelon
AD	Item to be assembled at depot maintenance levels.

Code	Definition
XA	Item is not procured or stocked because the requirements for the item will result in the replacement of the next higher assembly.
XB	Item is not procured or stocked. If not available through salvage, requisition.
XC	Installation drawings, diagram, instructions sheet, field service drawing, that is identified by manufacturer part number.
XD	A support item that is not stocked. When required, item will be procured through normal supply channels.

(*) NOTE

For USAF and the USA Safeguard Program, only Code "F" will be used to denote intermediate maintenance. On joint programs use of either code F or H by the joining service will denote intermediate maintenance USAF and the USA Safeguard program.

(2) Uniform Maintenance Codes applicable to all Military Services: GENERAL: Maintenance Codes are assigned to indicate the levels of maintenance authorized to USE and REPAIR support items.

The maintenance codes are in the third and fourth position of the Uniform SMR Code Format.

(a) USE (THIRD POSITION): The maintenance code entered in the third position indicates the lowest level maintenance level authorized to remove, replace, and use the support item. The maintenance code entered in the third position indicates one of the following levels of maintenance.

Code	Application/Explanation
O	Support item is removed, replaced, used at the organizational level of maintenance.
F	Support item is removed, replaced, used at the following intermediate levels: USAF - Intermediate (*) USA - Direct Support (*) USMC - 3rd Echelon
G	Support item is removed, replaced, used at both afloat and ashore intermediate levels: Navy Only.
H	Support item is removed, replaced, used at the following intermediate levels: USAF - Intermediate (*) USA - Direct Support (*) USMC - 4th Echelon

(*) NOTE

For USAF and the USA Safeguard Program, only Code "F" will be used to denote intermediate maintenance. On joint programs use of either code F or H by the joining service will denote intermediate maintenance USAF and the USA Safeguard program.

Code	Application/Explanation
D	Support items that are removed, replaced, used at depot only: USAF - Depot, Mobile Depot and Specialized Repair Activity USA - Depot, Mobile Depot and Specialized Repair Activity USMC - Depot

- (b) REPAIR (FOURTH POSITION): The maintenance code entered in the fourth position indicates whether the item is to be repaired and identifies the lowest maintenance level with the capacity to perform complete repair (i.e., all authorized maintenance functions).

Code	Application/Explanation
0	The lowest maintenance level capable of complete repair of the support item is the organizational level.
F	The lowest maintenance level capable of complete repair of the support item is the following intermediate level: USAF - Intermediate (*) USA - General Support (*) USMC - 4th Echelon
H	The lowest maintenance level capable of complete repair of the support item is the following intermediate level: USAF - Intermediate (*) USA - General Support (*) USMC - 4th Echelon

(*) NOTE

For USAF and the USA Safeguard Program, only Code "F" will be used to denote intermediate maintenance. On joint programs use of either code F or H by the joining service will denote intermediate maintenance USAF and the USA Safeguard program.

D	The lowest maintenance level capable of complete repair of the support item is the depot level. USAF - Depot, Mobile Depot, and Specialized Repair Activity. USA - Depot, Mobile Depot and Specialized Repair Activity. USMC - Depot
L	Repair restricted to designated Specialized Repair Activity.
Z	Nonrepairable. No repair is authorized.
B	No repair is authorized. The item may be reconditioned by adjusting, lubricating, etc., at the user level. No parts or special tools are procured for the maintenance of this item.

- (3) Uniform recoverability codes applicable to all Military Services: GENERAL : Recoverability codes are assigned to support items to indicate the disposition action on unserviceable items. The recoverability code is entered in the fifth position of the Uniform SMR code Format as follows:

Recoverability Codes	Definition
Z	Nonrepairable item. When unserviceable, condemn and dispose at the level indicated in column 3.
O	Repairable item when uneconomically repairable, condemn and dispose at organizational level.
F	Repairable item. When uneconomically repairable, condemn and dispose at the following intermediate levels: USAF - Intermediate (*) USA - Direct Support (*) USMC - 3rd Echelon
H	Repairable item. When uneconomically repairable, condemn and dispose at the following levels: USAF - Intermediate (*) USA - General Support (*) USMC - 4th Echelon

(*) NOTE

For USAF and the USA Safeguard Program, only Code “F” will be used to denote intermediate maintenance. On joint programs use of either code F or H by the joining service will denote intermediate maintenance USAF and the USA Safeguard program.

D	Repairable item. When beyond lower level repair capability, return to depot. Condemnation and disposal not authorized below depot level.
L	Repairable item. Repair, condemnation and disposal not authorized below depot/Specialized Repair Activity level.
A	Item requires special handling or condemnation procedures because of specific reasons (i.e., precious metal content, high-dollar value, critical material or hazardous material). Refer to appropriate manuals/directives for specific instructions.

c. (USMC) Special Stockage Indicator Code and Replacement Factor Column (3).

(1) **Special Stockage Indicator Code (Column 3a).** This column reflects the condition under which certain maintenance parts, (parts assigned NSN’S and coded in the “P” series source code of the MSR code), are stocked. The codes are explained as follows:

Code	Description
No code	Indicates that the part may or may not be authorized in initial allowances to using or supporting organizations. The manner of determining initial issue allowances is explained in paragraph (2) below.
I	Applied to maintenance parts for which predicted consumption would not warrant inclusion in Mount-Out but, for which a quantity of one (1) is authorized as insurance for Mount-Out using a 360-clay criteria. This criteria is based on the total density of equipments employed by the DIV/WING TEAM. Mount-Out allowances, so authorized, will be stocked by the FSR or the MWSG in the case of MARINE Wing peculiar equipment, as applicable.

Code	Description
D	Applied to maintenance parts that are not considered critical or essential to be on hand and are, therefore, not authorized in initial; however, these items are stocked within the Supply System and may be requisitioned based upon usage.
T	Indicates that the part is authorized in garrison operating allowances in order to comply with state and local laws; however, the part is not authorized in Mount-One since it is not combat essential.

(2) Replacement Factor (Column 3b). This column reflects the replacement factor assigned to each National Stock Numbered maintenance repair part on its first appearance in the publication. The replacement factor, expressed as a decimal, indicates the average rate at which the type of item so coded has been used by Marine Corps field units or the rate at which design engineers anticipate the item will fail, wear out, or otherwise require replacement. All computations are based on a replacement period of one year. Therefore, a replacement factor of 0.08, applied to an item in this stock list, indicates that eight out of every one hundred of such items used in the end item of equipment to which this publication pertains, is predicted to need replacement in one year. Likewise, 0.004 reflects that four out of every thousand in use are predicted to require replacement in one year, while 2.0 shows that every one in use is predicted to be replaced twice during each year.

- (a) Initial authorized stockage levels of consumable and salvageable items for an organization are to be computed for predicted consumption based on the number of items employed and/or supported by an organization within the number of days for which stockage is authorized. In computing Garrison Operating Stock or Mount-Out, authorized levels can be determined by the requiring Marine Corps unit by multiplying the replacement factor times the quantity used per equipment, times the number of end items employed by the using organization, or supported by the service organization, times the authorized day level expressed in months and divided by 12. Specific formulas and examples are provided in Marine Corps Order, MCO P4400.79.

The replacement factors used in initial stockage computations, should be revised, if warranted, after significant usage is experienced in accordance with the guidelines of MCO 4400.32A. The following formula replacement factor, “X” represents actual usage experience (1 year), “A” represents the application per equipment, and “B” represents the number of equipments supported.

$$\frac{X}{X}$$

$$W = A \times B$$

- (b) Initial allowances for maintenance float items (recoverability codes “R” and “D”) for the FMF and appropriate post and stations are as furnished by Initial Issue Actions.

Changes to maintenance replacement rates resulting from actual usage may require recomputation of maintenance float allowances by holding units. Any required recomputation of maintenance float allowances will be made in accordance with MCO 4600.6.

- (c) The replacement factor for same as (S/A) items is indicated upon the first appearance of the item in the major combination, component or assembly.

d. (ALL) National Stock Number (Column 4). Indicates the National Stock Number assigned to the item and will be used for requisitioning purposes.

e. (ALL) Description, (Column 5). Indicates the Federal item name and any additional description of the item required. The abbreviation "w/e" used as part of the nomenclature, indicates the National Stock Number, includes all armament, equipment, accessories and repair parts issued with the item. A part number or other reference number is followed by the applicable five digit Federal Supply Code for Manufacturer. If two reference numbers and Federal Supply Codes for manufacturer are listed, the first listing refers to the Department of the Defense Drawing Number, the second listing refers to the actual part manufacturer. Items that are included in kits and sets are listed below the name of the kit or set with the quantity of each item in the kit or set indicated in the Quantity Incorporated in Unit column.

f. (ALL) Unit of Measure (V/M) (Column 6) indicates the standard of the basic quantity of the listed item as used in performing the actual maintenance function. This measure is expressed by a two-character alphabetical abbreviation (e.g., ea, in, jr, etc.). When the unit of measure differs from the unit of issue, the lowest unit of issue that will satisfy the required unit of measure will be requisitioned.

g. (ALL) Quantity Incorporated in Unit, (Column 7). Indicates the quantity of the item used in the assembly group. A "V" appearing in this column in lieu of a quantity indicates that a definite quantity cannot be indicated (e.g., shims, spacers, etc.).

h. (MC) Quantity per Equipment, (Column 8). Indicates the consolidated quantity of a maintenance part used on an -end item upon every appearance of the part in this publication.

4. SPECIAL INFORMATION

a. (ALL) Identification of the usable on codes is:

Code	Used on
A	MEP-15A
B	MEP-25A

Uncoded items are applicable to all models.

b. Army organizational maintenance personnel will extract the items which they require from Section II, 3rd or 4th position of column 2 the direct and general support RPSTL. Parts which are manufactured or assembled at a higher level than that authorized to install the part are indicated by use of higher level code in the source column.

c. Stockage Information.

- (1) Air Force stockage information is contained in Initial Supply Support Lists issued separately from this publication by the Sacramento Air Logistics Center in accordance with AFM 67-1, part 1, chapter 12.
- (2) Marine Corps stockage information is contained in column 3a and 3b of the tabular listing of this publication.
- (3) Army stockage is demand based in accordance with AR 710-2. Repair parts listed in this publication represent those authorized for use at indicated maintenance levels and will be requisitioned on an as-required basis until stockage is justified in accordance with AR 710-2.

d. In the part list, some of the items are identified to show that they are a component or components of the items under which they are indented.

5. HOW TO LOCATE REPAIR PARTS

a. (ALL) When National Stock Number or reference number is unknown:

- (1) Using the table of contents, determine the functional group; i.e., batteries and related parts, exhaust and breather pipes, within which the repair part belongs. This is necessary since illustrations are prepared for functional groups, and listings are divided into the same groups.

- (2) Find the illustration covering the functional group to which the repair part belongs.
- (3) Identify the repair part on the illustration and note the illustration figure and item number of the repair part.
- (4) Using the Repair Parts Listing, find the figure and item number noted on the illustration.

b. (ALL) When National stock number or reference number is known:

- (1) Using the Index or National Stock Numbers and Reference Numbers, find the pertinent national stock number or reference number. This index is in ascending NSN sequence followed by a list of reference numbers in alphanumeric sequence, cross-referenced to the illustration figure number and item number.
- (2) After finding the figure and item number, locate the figure and item number in the repair parts list.

6. (F) USE OF THE REFERENCE DESIGNATOR INDEX SECTION

This Section (Section V) is used when the reference designator is know or identified by other technical manuals supporting this equipment. The reference number is given in this Section. If description or location is desired, note the figure and item number. Turn to Section II to the noted figure and item number. The location of the part and description is given in this listing.

7. ABBREVIATIONS

Abbreviation	Definition	Abbreviation	Definition
AC	alternating current	lg.	long (length)
AWE	American Wire Gage	lh	left hand
DC	direct current	mtg	mounting
ea	each	No.	number
ft	foot (feet)	rh	right hand
Hz	hertz	R.P.M.	revolutions per minute
in	inch(es)	thd.	thread(s)(ed)
kw	kilowatt	v	volts

8. FEDERAL SUPPLY CODES FOR MANUFACTURERS

(Not applicable)

9. RECOMMENDATIONS FOR MAINTENANCE PUBLICATION IMPROVEMENTS

Reports of errors, omissions, and recommendations for improving this publication by the individual user is encouraged. Reports should be submitted as follows:

- a. (F) Air Force-AFTO Form 22 in accordance with T.O. 00-5-1, directly to: Commander, Sacramento Air Logistics Center, ATTN: SM-ALC-MMEDT, McClellan AFB, CA 95652.
- b. (A) Army -DA Form 2028, directly to: Commander, US Army Troop Support Command, ATTN: AMSTR-MCTS, 4300 Goodfellow Boulevard, St.Louis, MO 63120-1798.
- c. (MC) Marine Corps. -by NAVMC Form 10772 directly to: Commanding General, U.S. Marine Corps, ATTN: 850, Albany, GA 31704.

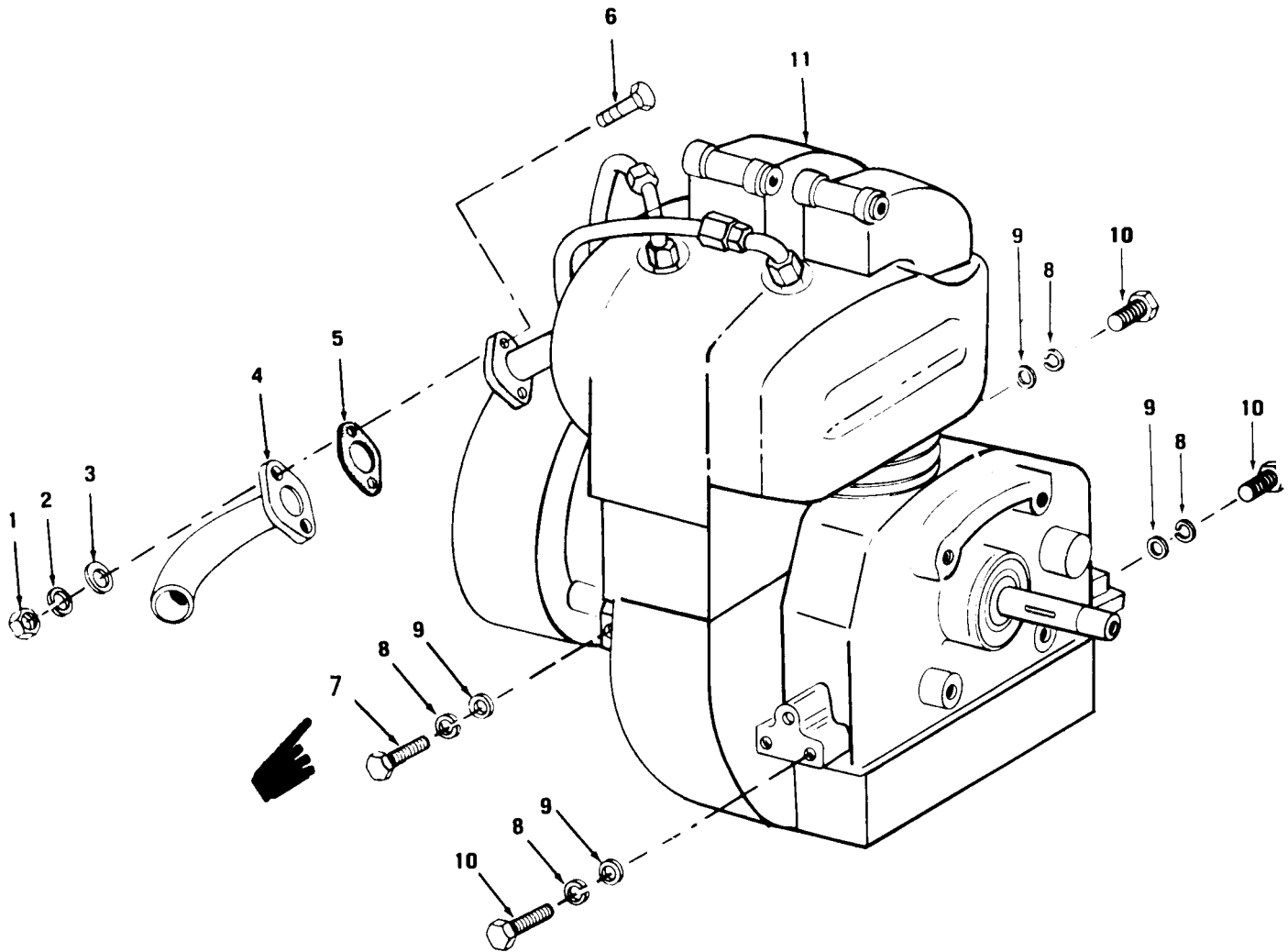

Figure 1. Engine Assembly

SECTION II. REPAIR PARTS LIST												
(1)		(2)				(3)		(4)	(5)	(6)	(7)	(8)
ILLUSTRATION		SMR CODE				USMC		NATIONAL	DESCRIPTION	USABLE	QTY	USMC
A	B	A	B	C	D	A	B	STOCK		ON	INC	QTY
FIG.	ITEM	ARMY	AIR	NAVY	USMC	SSI	REPL	NUMBER	REF NUMBER	CODE	U/M	PER
NO.	NO.		FORCE				FACTOR					EQUIP
GROUP 01-ENGINE ASSEMBLY												
1	1	PAOZZ	PAFZZ		PAOZZ			5310-00-768-0319	NUT, PLAIN, HEXAGON MS51968-2	96906	EA	2
1	2	PAOZZ	PAFZZ		PAOZZ			5310-00-582-5965	WASHER, LOCK MS35338-44	96906	EA	2
1	3	PAOZZ	PAFZZ		PAOZZ			5310-00-809-4058	WASHER, FLAT MS27183-10	96906	EA	2
1	4	PAOZZ	PAFZZ		PAFZZ			2990-00-065-6794	PIPE EXHAUST 13208E8525	97403	EA	1
1	5	PAOZZ	PAFZZ		PAOZZ			5330-00-797-3506	GASKET MTG 9786E50-2	02978	EA	1
1	6	PAOZZ	PAFZZ		PAOZZ			5305-00-267-8974	SCREW, CAP, HEXAGON HEAD MS90726-8	96906	EA	2
1	7	PAFZZ	PAFZZ		PAFZZ			5305-00-071-2239	SCREW, CAP, HEXAGON HEAD ENGINE MTG MS90725-12	96906	EA	3
1	8	PAFZZ	PAFZZ		PAFZZ			5310-00-582-5965	WASHER, LOCK MTG, 1/4IN SCREW SIZE MS35338-44	96906	EA	8
1	9	PAFZZ	PAFZZ		PAFZZ			5310-00-809-4058	WASHER, FLAT MTG, 1/4IN SCREW SIZE MS27183-10	96906	EA	8
1	10	PAFZZ	PAFZZ		PAFZZ			5305-00-068-0502	SCREW, CAP, HEXAGON HEAD ENG. MTG 1/4IN THD SIZE 3/4IN LG MS90728-6	96906	EA	4
1	11	PAFHH	PAFDD		PAFHH			2805-00-072-4871	ENGINE, GASOLINE MS39298	96906	EA	1

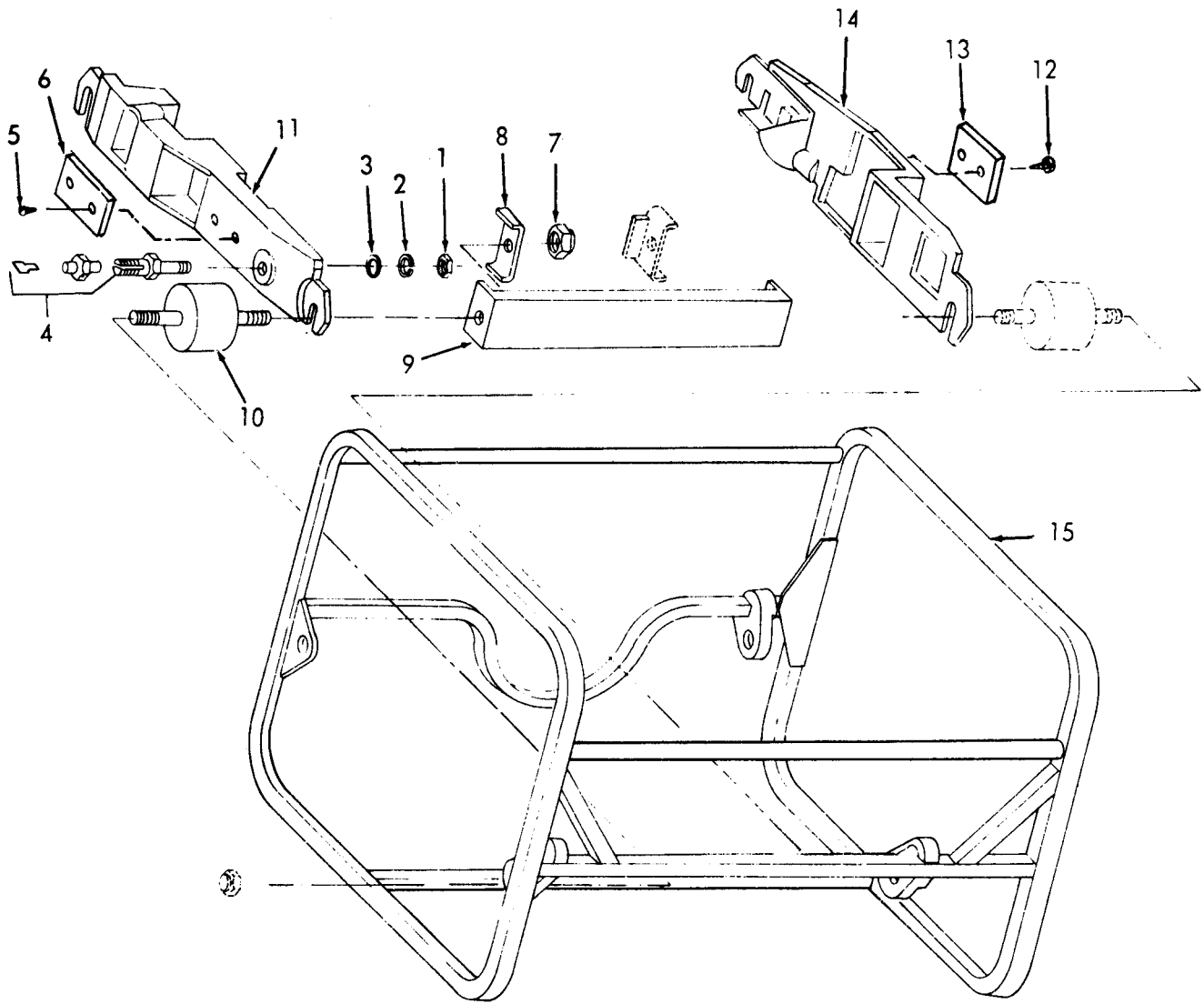

Figure 2. Frames Assembly

SECTION II. REPAIR PARTS LIST

(1) ILLUSTRATION		(2) SMR CODE				(3) USMC			(4) NATIONAL	(5) DESCRIPTION	(6) USABLE	(7) QTY	(8) USMC
A	B	A	B	C	D	A	B	STOCK		ON	INC	QTY	
FIG.	ITEM	ARMY	AIR	NAVY	USMC	SSI	REPL	NUMBER	REF NUMBER	CODE	U/M	PER	
NO.	NO.		FORCE				FACTOR					EQUIP	
GROUP 02-FRAME ASSEMBLY													
2	1	PAOZZ	PAFZZ		PAOZZ			5310-00-584-7996	NUT,PLAIN,HEXAGON MTG GROUND TERMINAL, 1/4-20 THD SIZE MS16203-25	96906	EA	1	
2	2	PAOZZ	PAFZZ		PAOZZ			5310-00-187-2425	WASHER,LOCK MS35338-120	96906	EA	1	
2	3	PAOZZ	PAFZZ		PAOZZ			5310-00-805-4864	WASHER,FLAT GROUND TERMINAL MS15795-511	96906	EA	1	
2	4	PAOZZ	PAFZZ		PAOZZ			5940-00-021-3321	TERMINAL,STUD 13208E5820-6	97403	EA	1	
2	4	PAOZZ	PAFZZ		PAOZZ			5940-00-958-0349	TERMINAL,STUD 13208E5820-2	97403	EA	1	
2	5	PAOZZ	PAFZZ		PAOZZ			5305-00-175-3230	SCREW,DRIVE MS21318-14	96906	EA	2	
2	6	PBOZZ	XBFZZ		PBOZZ			9905-00-477-4137	PLATE,IDENTIFICATION 13211E6730	97403	EA	1	
2	7	PAFZZ	PAFZZ		PAFZZ			5310-00-857-4957	NUT,SELF-LOCKING,HEXAGON RAIL TO FRAME, 3/8-24 THD SIZE MS21044D6	96906	EA	8	
2	8	XBFZZ	XBFZZ		XBFZZ				RETAINER,NUT AND MOUNT BRACE 13214E0108	97403	EA	4	
2	9	XBFZZ	XBFZZ		XBFZZ				BRACE 13214E0107	97403	EA	1	
2	10	PAFZZ	PAFZZ		PAFZZ			5340-00-905-1679	MOUNT,RESILIENT: ENGINE AND GENERATOR 13214E0109	97403	EA	4	
2	11	PAFZZ	PAFZZ		PAFZZ			6115-00-921-6881	RAIL,MOUNTING: ENGINE AND GENERATOR, OIL FILLER SIDE 13214E0105	97403	EA	1	
2	12	PAOZZ	PAFZZ		PAOZZ			5305-00-175-3230	SCREW,DRIVE NAME PLATE MOUNTING MS21318-14	96906	EA	1	
2	13	PBOZZ	XBFZZ		PBOZZ			9905-00-079-8369	NAME PLATE,FUEL VALVE 13208E8456		EA	1	
2	14	PAFZZ	PAFZZ		PAFZZ			6115-00-921-6880	RAIL,MOUNTING ENGINE GENERATOR,FUEL TANK SIDE 13214E0104	97403	EA	1	
2	15	XBFZZ	XBFZZ		XBOZZ				FRAME,GENERATOR 13214E0101	97403		1	

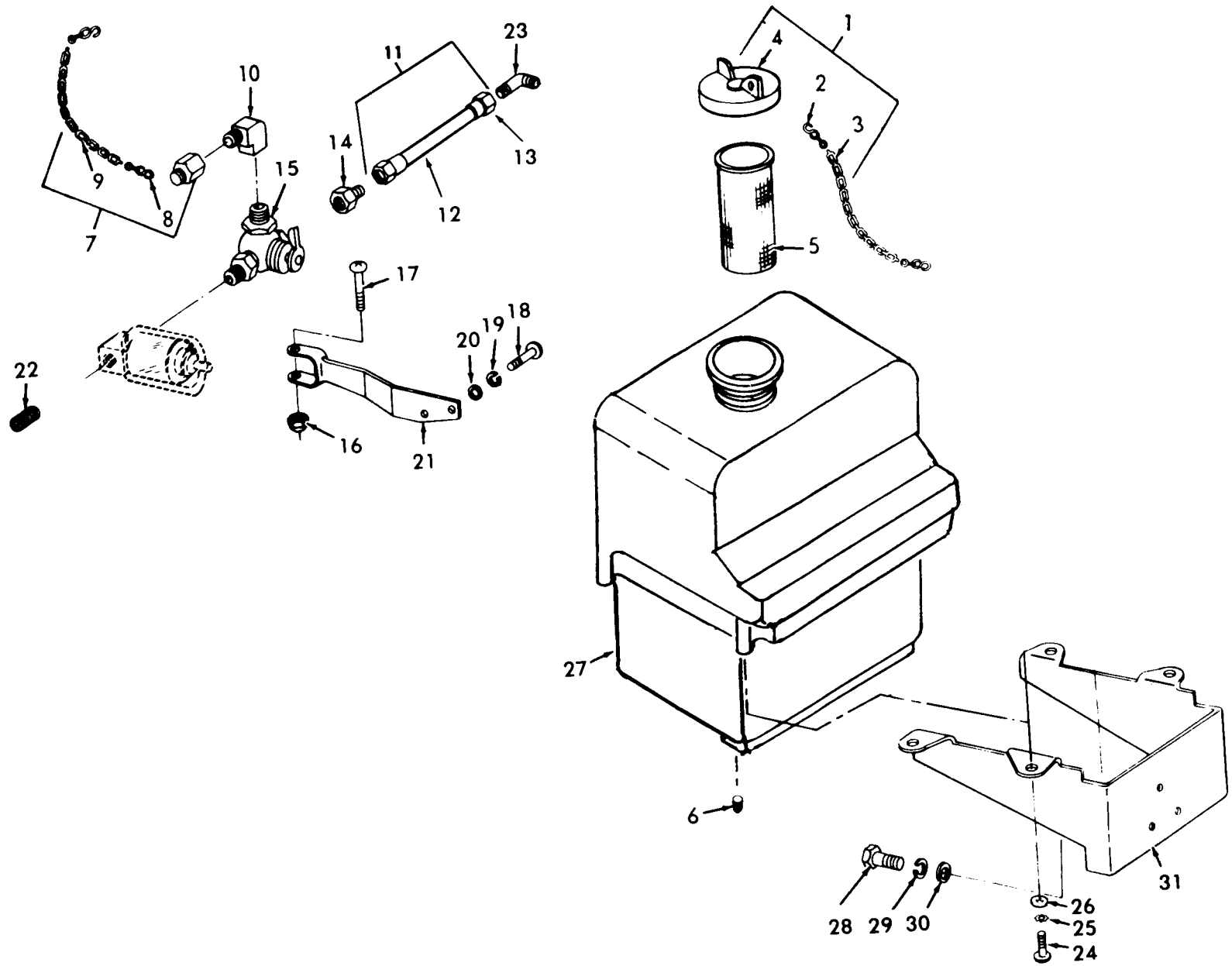

Figure 3. Fuel System

SECTION II. REPAIR PARTS LIST

(1) ILLUSTRATION		(2) SMR CODE				(3) USMC		(4) NATIONAL	(5) DESCRIPTION	(6) USABLE	(7) QTY	(8) USMC
A	B	A	B	C	D	A	B	STOCK	REF NUMBER	ON	INC	QTY
FIG. NO.	ITEM NO.	ARMY	AIR FORCE	NAVY	USMC	SSI	REPL FACTOR	NUMBER		CODE	U/M	PER EQUIP
GROUP 03-FUEL SYSTEM												
3	1	PAOZZ	PAOZZ		PAOZZ			2910-00-904-2645	CAP, FILLER, OPENING ASSEMBLY, FUEL CHAIN 13214E0115	97403	EA	1
3	2	PAOZZ	PAOZZ		PAOZZ			4030-00-270-5436	HOOK, CHAIN, RETAINING MS87006-3	96906	EA	2
3	3	PAOZZ	XAOZZ		PAOZZ			4010-00-267-9618	CHAIN, CAP, RETAINING (10 IN REQUIRED) NAS1455-00-8C	80205	FT	V
3	4	PAOZZ	XAOZZ		PAOZZ			2910-00-904-2645	CAP, FILLER OPENING 13213E4065	97403	EA	1
3	5	PAOZZ	PAOZZ		PAOZZ			2910-00-065-6793	STRAINER ELEMENT 13208E5834	97403	EA	1
3	6	PAOZZ	PAFZZ		PAOZZ			4730-00-595-1074	PLUG, PIPE FUEL DRAIN TANK MS20913-1J	96906	EA	1
3	7	PAOZZ	PAOZZ		PAOZZ			4730-00-209-1561	CAP, TUBE ASSEMBLY 69-539-1	30554	EA	1
3	8	PBOZZ	XAOZZ		XAOZZ			4030-00-270-5436	HOOK, CHAIN MS87006-3	96906	E	2
3	9	PBOZZ	XAOZZ		XAOZZ			4010-00-160-0183	CHAIN (10 IN REQUIRED) RRC271	81348	FT	V
3	10	PAOZZ	PAFZZ		PAOZZ			4730-00-767-2615	ELBOW, PIPE TO TUBE SELECTOR VALVE 13218E0182-23	97403	EA	1
3	11	MOOZZ	MOOZZ		MOOZZ				HOSE ASSEMBLY, FUEL 87-500-1 MANUFACTURE FROM	30554	EA	1
3	12	PAOZZ	PAOZZ		PAOZZ			4720-00-857-1732	HOSE, NONMETALLIC MIL-H-27267-4	81349	FT	1
3	13	PAOZZ	PAOZZ		PAOZZ			4730-00-889-2474	FITTING, END MS27053-4C	96906	EA	2
3	14	PAOZZ	PAFZZ		PAOZZ			4730-00-277-7910	ADAPTER, STRAIGHT 4-2-070103BA	81343	EA	1
3	15	PAFZZ	PAFZZ		PAOZZ			4820-00-925-7374	VALVE, PLUG FUEL SELECTOR 13208E5768	97403	EA	1
3	16	PAOZZ	PAFZZ		PAOZZ			5310-00-060-2039	NUT, SELF-LOCKING HEXAGON VALVE MTG NO MS20144D08	96906	EA	1
3	17	PAOZZ	PAFZZ		PAOZZ			5305-00-984-6198	SCREW, MACHINE, VALVE MTG NO THD SIZE 1 1/4 IN LG MS35206-250	96906	EA	2
3	18	PAOZZ	PAFZZ		PAOZZ			5305-00-984-6210	SCREW, MACHINE, BRACE MTG NO 10-24 THD SIZE, 1/2 LG MS35206-263	96906	EA	2
3	19	PAOZZ	PAFZZ		PAOZZ			5310-00-045-3296	WASHER, LOCK MTG NO 10 SCREW SIZE MS35338-43	96906	EA	2
7		CHANGE 3										

Section II. REPAIR PARTS LIST

(1) ILLUS- TRATION		(2) SMR CODE				(3) USMC		(4)	(5) DESCRIPTION	(6)	(7)	(8)
a	b	a	b	c	d	a	b	NATIONAL STOCK NUMBER	USABLE ON CODE	U/M	INC IN UNIT	QTY PER EQUIP
FIG NO.	ITEM NO.	ARMY	AIR FORCE	NAVY	USMC	SSI	REPL FACTOR		REF NUMBER & MFR CODE			
3	20	PAOZZ	PAPZZ		PAOZZ			5310-00-09-8546	WASHER FLAT UTO NO 10 SCREW SIZE MS27183-8 96906	EA	2	
3	21	PAOZZ	PAFZZ		PAOZZ			2910-00-485-8937	BRACE FUEL FILTER 13214E0116 97403	EA	1	
3	22	PAFZZ	PAFZZ		PAFZZ			4730-00-006-1465	NPPLE PIPE 14 IN CLOSE MS51872-105 96906	EA		
3	23	PAFZZ	PAFZZ		PAOZZ			4730-00-287-1032	ELBOW PIPE TO TUBE TANK TO HOSE MS20822-48 96901	EA	1	
3	24	PAOZZ	PAFZZ		PAOZZ			5305004-06 -504	SCREW CAP HEXAGON HEAOD TO i/4-28 THO SIZE 134 IN LG MS9072S-3 96906	EA	4	
3	25	PAOZZ	PAFZZ		PAOZZ			5310-00-582-5965	WASHER LOCK EXTERNAL TEETH 1/4 P SCREW SIZE MS35338-44 96906	EA	4	
3	26	PAOZZ	PAFZZ		PAOZZ			5310-0-09-4058	WASHER FLAT TANK MOT 1/4 N SCREW SIZE MS27183-10 96906	EA	4	
3	27	PAOZZ	PAOZZ		PAOZZ			2910-00-1-4254	TANK FUEL ENO1NE 13217E6391 97403	EA	1	
3	28	PAOZZ	PAFZZ		PAOZZ			5305-00-071-250	SCREW CAP HEXAGON HEAO MS90728-12 96906	EA	3	
3	29	PAOZZ	PAFZZ		PAOZZ			5310-00-52-5965	WASHER LOCK TANK UT t/4 IN SCREW SIZE	EA	3	
3	30	PAOZZ	PAFZZ	PAOZZ				5310-0-009S405	WASHER FLAT BRACKET UTO 1/4 IN SCREW SIZE MS27183-10 97403	EA	3	
3	31	PBOZZ	XBFZZ	XBOZZ					BRACKET FUEL TANK 13214E0110 97403	EA	1	

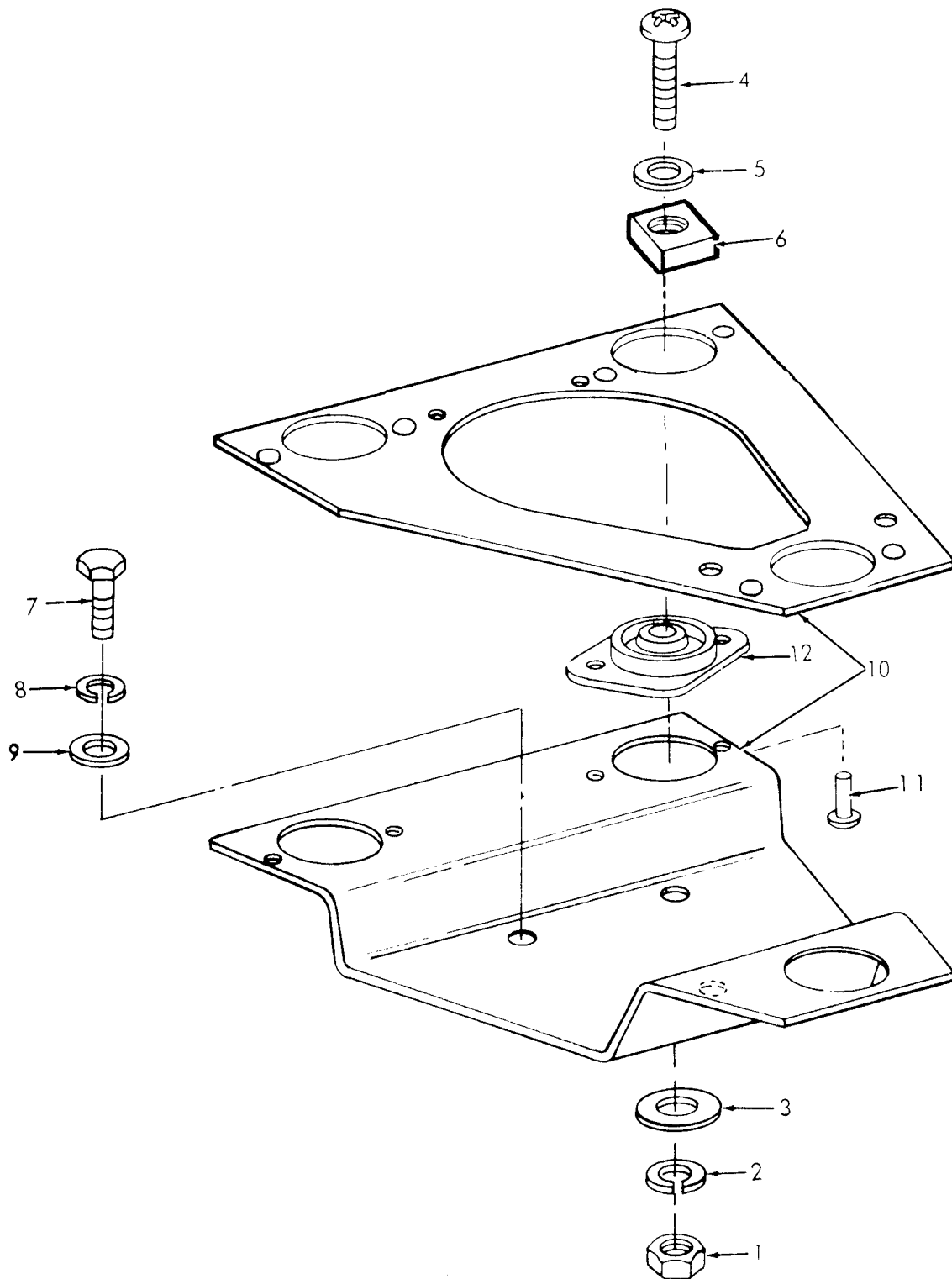

Figure .4. Control Box Mounting

SECTION II. REPAIR PARTS LIST

(1) ILLUSTRATION		(2) SMR CODE				(3) USMC		(4) NATIONAL STOCK NUMBER	(5) DESCRIPTION		(6) USABLE ON CODE	(7) QTY INC IN U/M	(8) USMC QTY PER EQUIP
A	B	A	B	C	D	A	B						
FIG. NO.	ITEM NO.	ARMY	AIR FORCE	NAVY	USMC	SSI	REPL FACTOR	REF NUMBER	MFR CODE				
GROUP 04-CONTROL BOX ASSEMBLY													
4	1	PAFZZ	PAFZZ		PAFZZ			5310-00-934-9757	NUT, PLAIN, HEXAGON NO 8-32 THD SIZE MS35649-282	96906	EA	3	
4	2	PAFZZ	PAFZZ		PAFZZ			5310-00-045-3299	WASHER, LOCK NO 8 SCREW SIZE MS35338-42	96906	EA	3	
4	3	PAFZZ	PAFZZ		PAFZZ				WASHER, FLAT SNUBBING CONTROL BOX 13214E0119	97403	EA	3	
4	4	PAFZZ	PAFZZ		PAFZZ			5305-00-984-6198	SCREW, MACHINE CONTROL BOX MTG NO 8-32 THD SIZE, 1/4 IN LG MS35206-250	96906	EA	3	
4	5	PAFZZ	PAFZZ		PAFZZ			5310-00-809-8544	WASHER, FLAT SCREW SIZE MS27183-7	96906	EA	3	
4	6	XBFZZ	XBFZZ		XBFZZ				WASHER, SQUARE CONTROL BOX MTG 13214E0120	97403	EA	3	
4	7	PAFZZ	PAFZZ		PAFZZ			5305-00-068-0501	SCREW, CAP, HEXAGON HEAD: BRACKET MTG 1/4-20 THD SIZE, 5/8 IN LG MS90725-5	96906	EA	3	
4	8	PAFZZ	PAFZZ		PAFZZ			5310-00-582-5965	WASHER, LOCK BRACKET MTG 1/4 IN SCREW SIZE MS35338-44	96906	EA	3	
4	9	PAFZZ	PAFZZ		PAFZZ			5310-00-809-4058	WASHER, FLAT BRACKET MTG 1/4IN SCREW SIZE MS27183-10	96906	EA	3	
4	10	XBFZZ	XBFZZ		XBFZZ			6115-00-522-3993	BRACKET, MOUNTING CONTROL BOX 1.3214E+121	97403	EA	1	
4	11	PAFZZ	XBFZZ		PAFZZ			5320-00-118-1995	RIVET, SOLID MS20470B4-6	96906	EA	10	
4	12	PAFZZ	PAFZZ		PAFZZ			5340-00-467-2550	MOUNT, RESILIENT CONTROL BOX 13213E0037-3	97403	EA	3	

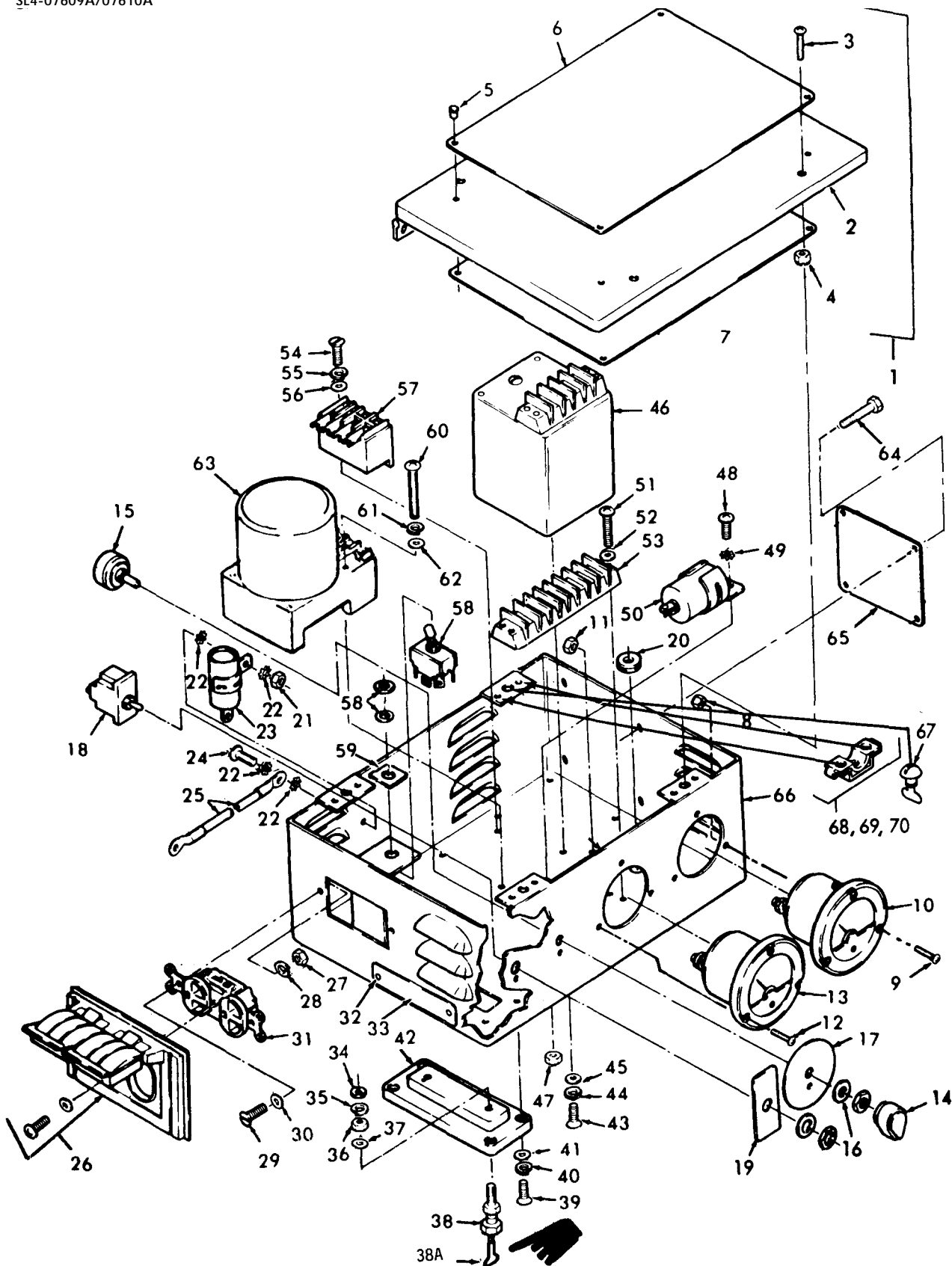

Figure 5. Box Assembly 60 HZ

SECTION II. REPAIR PARTS LIST

(1) ILLUSTRATION A B FIG. ITEM NO. NO.	(2) SMR CODE A B C D ARMY AIR FORCE NAVY USMC	(3) USMC A B SSI REPL FACTOR	(4) NATIONAL STOCK NUMBER	(5) DESCRIPTION REF NUMBER	MFR CODE	USABLE ON CODE	(6) QTY INC IN U/M	(7) USMC QTY PER EQUIP	(8) USMC QTY PER EQUIP
5	PBFFF AFFFF		6110-00-904-5631	CONTROL BOX ASSEMBLY 13214E0150	97403	A	EA	1	
5	1 PBFZZ XBFZZ		6110-01-035-0427	CONTROL BOX AND COVER 13217E6396	97403	A	EA	1	
5	2 PAFZZ XBFZZ			COVER CONTROL BOX 13214E0151	97403	A	EA	1	
5	3 PAFZZ PAFZZ		5305-00-083-6645	SCREW, ASSEMBLED WASHER NAS1301C10-B	80205	A	EA	2	
5	4 PAFZZ PAFZZ		5310-00-383-3658	NUT, SELF-LOCKING 13217E6402-10	97403	A	EA	2	
5	5 PAOZZ PAOZZ		5320-00-721-9075	RIVET, BLIND, PLATE MTG WIRING DIAGRAM MS20604B3W2	96906	A	EA	4	
5	6 PBOZZ XBFZZ		9905-00-421-1300	PLATE, INSTRUCTION OPERATING 13208E8529	97403	A	EA	1	
5	7 PBOZZ XBOZZ		6110-00-453-8971	PLATE, WIRING DIAGRAM 1.3214E+156	97403	A	EA	1	
5	8 PAOZZ PAFZZ		5310-00-836-3520	NUT, PLAIN, ASSEMBLED WASHER 69-561-1	30554	A	EA	3	
5	9 PAOZZ PAFZZ		5305-00-983-6730	SCREW MACHINE MS35206-218	96906	A	EA	3	
5	10 PAOZZ PAFBZ		6625-00-054-2038	METER, ELECTRICAL FREQUENCY 13211E6992-1	97403	A	EA	1	
5	11 PAOZZ PAFZZ		5310-00-836-3520	NUT, PLAIN, ASSEMBLED 69-561-1	30554	A	EA	3	
5	12 PAOZZ PAFZZ PAOZZ		5305-00-983-6730	SCREW, MACHINE MS35206-218	96906	A	EA	3	
5	13 PAOZZ PAFBZ		6625-00-065-5301	VOLTMETER 13211E6905	97403	A	EA	1	
5	14 PAOZZ PAFZZ			KNOB, CONTROL VARIABLE RESISTOR MS915280K18	96906	A	EA	1	
5	15 PAOZZ PAFZZ		5905-00-948-2116	RESISTOR, VARIABLE 12.5W, 1500 OHMS 13208E8460-2	97403	A	EA	1	
5	16 PAFZZ PAFZZ		5310-00-809-4058	WASHER, FLAT MS27183-10	96906	A	EA	1	
5	17 PBOZZ PAFZZ		9905-00-057-6308	PLATE, INSTRUCTION VOLTAGE CONTROL 13208E8464	97403	A	EA	1	
5	18 PAOZZ PAFZZ		5930-00-655-4247	SWITCH, TOGGLE CONTROL ON-OFF MS24524-22	96906	A	EA	1	
5	19 PBOZZ XBFZZ		9905-00-256-2138	PLATE, INSTRUCTION SWITCH CONTROL 13208E8462	97403	A	EA	1	
5	20 PAFZZ XBFZZ		5325-00-276-6100	GROMMET, NONMETALLIC AN931-8-13	88044	A	EA	1	

13 CHANGE 2

SECTION II. REPAIR PARTS LIST

(1)		(2)		(3)				(4)	(5)	(6) (7) (8)		
ILLUSTRATION		SMR CODE		USMC				NATIONAL	DESCRIPTION	USABLE	QTY	USMC
A	B	A	B	A	B	A	B	STOCK		ON	INC	QTY
FIG.	ITEM	AIR		C	D	REPL	NUMBER		REF NUMBER	CODE	U/M	PER
NO.	NO.	ARMY	FORCE	NAVY	USMC	FACTOR						EQUIP
5	21	PAOZZ	PAFZZ		PAOZZ			5310-00-761-6882	NUT, PLAIN, HEXAGON MS51967-2	96906	A	EA 1
5	22	PAPZZ	PAFZZ		PAOZZ			5310-00-889-2528	WASHER, LOCK MS45904-68	96906	A	EA 4
5	23	PAFZZ	PAFZZ		PAFZZ			5910-00-504-7418	CAPACITOR, FIXED 0.1.MFG 500V.AC CA36KFW104	81349	A	EA 1
5	24	PAOZZ	PAFZZ		PAOZZ			5305-00-988-1725	SCREW, MACHINE MS35206-281	96906	A	EA 1
5	25	PAOZZ	PAFZZ		PAOZZ			2590-00-944-6254	LEAD, ELECTRICAL, CONTROL BOX 13208E5853-20	97403	A	EA 1
5	16	PAOZZ	XBFZZ		PAOZZ			5975-00-844-1066	PLATE, WALL, ELECTRICAL 245AL	08556	A	EA 1
5	27	PAFZZ	PAFZZ		PAFZZ			5310-00-934-9747	NUT, PLAIN, HEXAGON MS35649-262	96906	A	EA 2
5	28	PAFZZ	PAFZZ		PAFZZ			5310-00-045-4007	WASHER, LOCK MS35338-41	96906	A	EA 2
5	29	PAOZZ	PAOZZ		PAOZZ			5305-00-958-5450	SCREW, MACHINE MS35190-240	96906	A	EA 2
5	30	PAOZZ	PAOZZ		PAOZZ			5310-00-983-8483	WASHER, FLAT MS27183-5	96906	A	EA 2
5	31	PAOZZ	PAFZZ		PAFZZ			5935-01-005-2323	CONNECTOR, RECEPTACLE, ELECTRICAL WC00596	81348	A	EA 1
5	32	PAOZZ	PAOZZ		PAFZZ			5320-00-721-9075	RIVET, BLIND TERMINAL NAMEPLATE MS20604B3WZ	96906	A	EA 2
5	33	PBOZZ	XBFZZ		PAFZZ			9905-00-140-1162	PLATE, IDENTIFICATION TERMINAL 13208E8465	97403	A	EA 1
5	34	PAOZZ	PAFZZ		PAOZZ			5310-00-584-7995	NUT, PLAIN, HEXAGON MS16203-27	96906	A	EA 2
5	35	PAOZZ	PAFZZ		PAOZZ			5310-00-187-2425	WASHER, LOCK TERMINAL MS35338-120	96906	A	EA 2
5	36	PAOZZ	PAFZZ		PAOZZ			5310-00-584-7996	NUT, PLAIN, HEXAGON MS16203-25	96906	A	EA 2
5	37	PAOZZ	PAFZZ		PAOZZ			5310-00-805-4864	WASHER, FLAT MS15795-511	96906	A	EA 2
5	38	PAOZZ	PAFZZ		PAOZZ			5940-00-958-0349	TERMINAL, STUD 13208E5820-2	97403	A	EA 2
5	38A	PAOZZ						9505-00-304-3814	WIRE, NONELECTRICAL QQ-W-423	81348	A	FT 2
5	39	PAOZZ	PAFZZ		PAOZZ			5305-00-984-6194	SCREW, MACHINE MS35206-246	96906	A	EA 4
5	40	PAOZZ	PAFZZ		PAOZZ			5310-00-045-3299	WASHER, LOCK MS35338-42	96906	A	EA 4
5	41	PAOZZ	PAFZZ		PAOZZ			5310-00-809-8544	WASHER, FLAT MS27183-7	96906	A	EA 4
5	42	PAOZZ	PAFZZ		PAOZZ			5970-00-908-6471	INSULATOR, PLATE TERMINAL 13214E0154	97403	A	EA 1
5	43	PAOZZ	PAFZZ		PAFZZ			5305-00-984-6191	SCREW, MACHINE MS35206-243	96906	A	EA 4

SECTION II. REPAIR PARTS LIST

(1) ILLUSTRATION A B FIG. ITEM NO. NO.	(2) SMR CODE A B C D ARMY AIR FORCE NAVY USMC	(3) USMC A B SSI REPL FACTOR	(4) NATIONAL STOCK NUMBER	(5) DESCRIPTION REF NUMBER MFR CODE	(6) USABLE ON CODE	(7) QTY INC IN U/M UNITS	(8) USMC QTY PER EQUIP
5 44	PAOZZ PAFZZ	PAFZZ	5310-00-809-8544	WASHER, FLAT MS27183-7 96906	A	EA 4	
5 45	PAOZZ PAFZZ	PAFZZ	5310-00-045-3299	WASHER, LOCK MS35338-42 96906	A	EA 4	
5 46	PAOZZ PAFZZ	PAFZZ	6115-00-940-0175	CONVERTER, CONTROL 13211E6901 97403	A	EA 1	
5 47	PAFZZ PAFZZ	PAFZZ	5310-00-761-6882	NUT, PLAIN, HEXAGON MS1967-2 96906	A	EA 1	
5 48	PAFZZ PAFZZ	PAFZZ	5305-00-988-1725	SCREW, MACHINE MS35206-281 96906	A	EA 1	
5 49	PAFZZ PAFZZ	PAFZZ	5310-00-889-2528	WASHER, LOCK MS45904-68 96906	A	EA 1	
5 50	PAFZZ PAFZZ	PAFZZ	5910-00-801-3483	CAPACITOR, FIXED 0.1 MFD, 500V, AC CA38KFW104 81349	A	EA 1	
5 51	PAFZZ PAFZZ	PAFZZ	5305-00-984-4992	SCREW, MACHINE MS35206-232 96906	A	EA 4	
5 52	PAFZZ PAFZZ	PAFZZ	5310-00-983-8483	WASHER, FLAT MS27183-5 96906	A	EA 4	
5 53	XBFZZ XBFZZ	XBFZZ		TERMINAL BOARD 38TB8 81349	A	EA 1	
5 54	PAFZZ PAFZZ	PAFZZ	5305-00-984-6197	SCREW, MACHINE MS35206-249 96906	A	EA 1	
5 55	PAFZZ PAFZZ	PAFZZ	5310-00-045-3299	WASHER, LOCK MS35338-42 96906	A	EA 1	
5 56	PAFZZ PAFZZ	PAFZZ	5310-00-809-8544	WASHER, FLAT MS27183-7 96906	A	EA 1	
5 57	PAFZZ PAFZZ	PAFZZ	6115-00-910-6845	TRANSDUCER, VOLTAGE 13214E0280 97403	A	EA 1	
5 58	PAOZZ PAFZZ	PAOZZ	5930-00-557-5175	SWITCH, TOGGLE, CONTROL VOLTAGE MS25126E3 96906	A	EA 1	
5 59	XBOZZ XBFZZ	XBOZZ		PLATE, VOLTAGE RECONNECT 13208E8459 97403	A	EA 1	
5 60	PAFZZ PAFZZ	PAFZZ	5305-00-984-6199	SCREW, MACHINE REGULATOR MS35206-251 96906	A	EA 4	
5 61	PAFZZ PAFZZ	PAFZZ	5310-00-045-3299	WASHER, LOCK REGULATOR MS35338-42 96906	A	EA 4	
5 62	PAFZZ PAFZZ	PAFZZ	5310-00-809-8544	WASHER, FLAT MS27183-7 96906	A	EA 4	
5 63	PAFZZ PAFZZ	PAFZZ	6110-00-903-4768	REGULATOR, VOLTAGE 13214E0260 97403	A	EA 1	
5 64	PAOZZ PAFZZ	PAOZZ	5320-00-721-9075	RIVET, BLIND MS20604B3W2 96906	A	EA 4	
5 65	PAOZZ XBFZZ	PAOZZ	9905-01-147-3718	PLATE, IDENTIFICATION 73-0506-5 30554	A	EA 1	
5 66	PBFZZ XBFZZ	XBFZZ		BOX, CONTROL 13214E0153-1 97403	A	EA 1	
5 67	PAOZZ PAOZZ	PAOZZ	5325-00-432-9796	TURNLOCK, STUD 13208E5845 97403	A	EA 2	

SECTION II. REPAIR PARTS LIST

(1)		(2)				(3)			(4)	(5)	(6)	(7)	(8)
ILLUSTRATION		SMR CODE				USMC			NATIONAL	DESCRIPTION	USABLE	QTY	USMC
A	B	A	B	C	D	A	B		STOCK		ON	INC	QTY
FIG.	ITEM	ARMY	AIR	NAVY	USMC	SSI	REPL	NUMBER				IN	PER
NO.	NO.		FORCE			FACTOR			REF NUMBER	MFR CODE	CODE	U/M	EQUIP
5	68	PAOZZ	PAOZZ		PAOZZ			5310-00-822-8525	SPLIT WASHER 13213E8162	97403		EA	2
5	69	PAOZZ	PAOZZ		PAOZZ			5310-00-845-7769	LOCK WASHER 13220E8321	97403		EA	2
5	70	PAOZZ	PAOZZ		PAOZZ			5325-00-282-7471	TURN RECEPTACLE 13213E5164	97403		EA	2

Change 1 16.1/(16.2 blank)

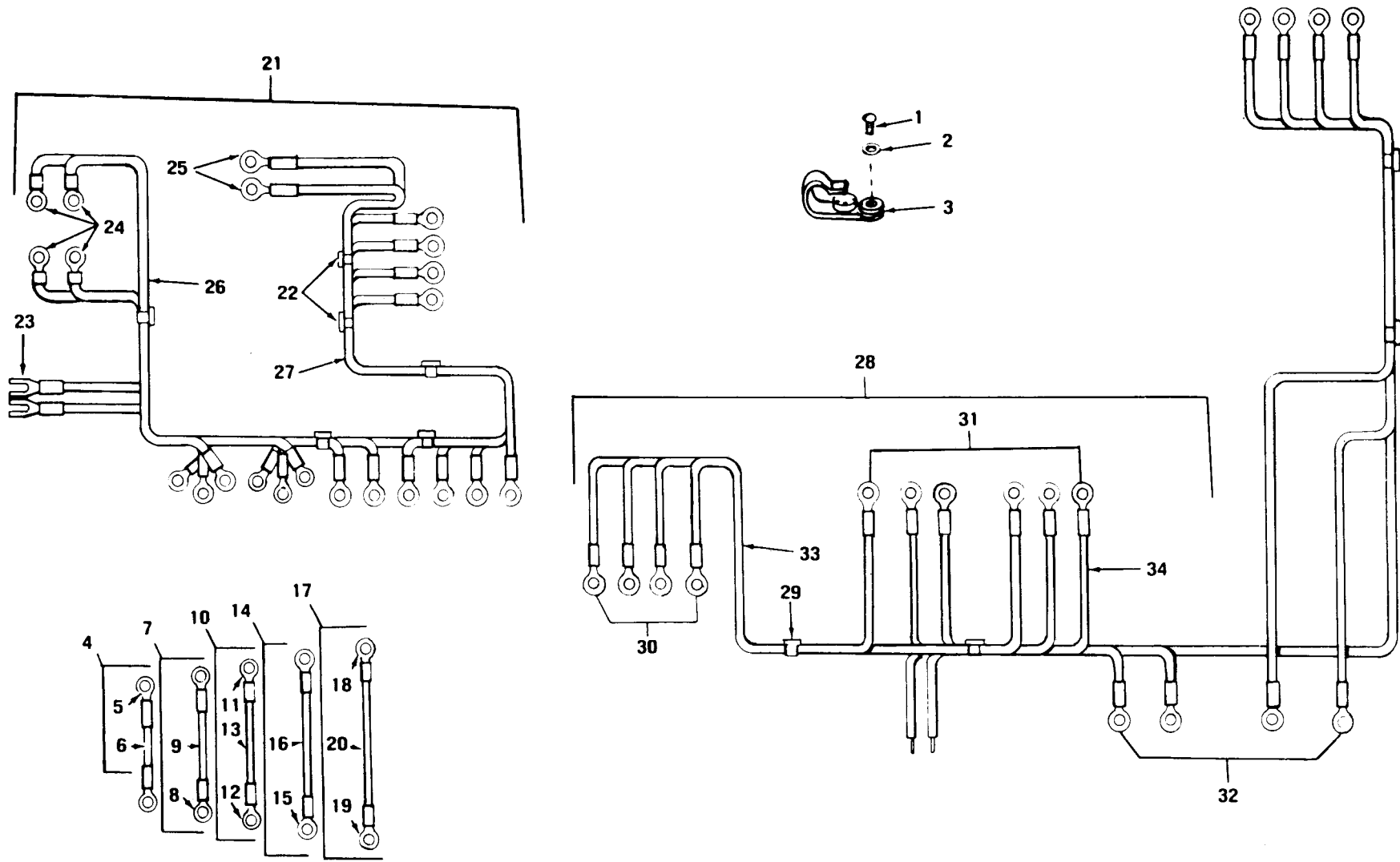

Figure 6. Wiring Harness 60 HZ

SECTION II. REPAIR PARTS LIST

(1) ILLUSTRATION		(2) SMR CODE				(3) USMC		(4) NATIONAL STOCK NUMBER	(5) DESCRIPTION		(6) USABLE ON CODE	(7) QTY INC IN UNITS	(8) USMC QTY PER EQUIP
A	B	A	B	C	D	A	B				U/M		
FIG. NO.	ITEM NO.	ARMY	AIR FORCE	NAVY	USMC	SSI	REPL FACTOR	REF NUMBER	MFR CODE				
6	1	PAFZZ	PAFZZ		PAFZZ			5305-00-984-6193	SCREW,MACHINE STRAP MTG NO MS35206-245	96906	A	EA 4	
6	2	PAFZZ	PAFZZ		PAFZZ			5310-00-809-8544	WASHER,FLAT STRAP MTG,NO SCREW SIZE MS27183-7	96906	A	EA 4	
6	3	PAFZZ	PAFZZ		PAFZZ			5975-00-906-2414	STRAP,TIEDOWN 13208E8536	97403	A	EA 4	
6	4	MFFFF	MFFZZ		MFFFF				LEAD,ELECTRICAL TOGGLE SWITCH TO GROUND TERMINAL 13214E0157-1	97403	A	EA 1	
6	5	PAFZZ	PAFZZ		PAFZZ			5940-00-113-8179	MANUFACTURE FROM TERMINAL,LUG MS25036-107	96906	A	EA 2	
6	6	PAFZZ	PAFZZ		PAFZZ			6145-00-578-7517	WIRE,ELECTRICAL 11/2IN REQUIRED M5086-1-16-9	81349	A	FT V	
6	7	MFFFF	MFFZZ		MFFFF				LEAD,ELECTRICAL TOGGLE SWITCH TO GROUND TERMINAL 13214E0157-2	97403	A	EA 1	
6	8	PAFZZ	PAFZZ		PAFZZ			5940-00-113-8179	MANUFACTURE FROM TERMINAL LUG MS25036-107	96906	A	EA 2	
6	9	PAFZZ	PAFZZ		PAFZZ			6145-00-578-7517	WIRE,ELECTRICAL 2IN REQUIRED M5086-1-16-9	81349	A	FT V	
6	10	MFFFF	MFFZZ		MFFFF				LEAD,ELECTRICAL: CAPACITOR TO TERMINAL BOARD 13214E0157-4	97403	A	EA 1	
6	11	PAFZZ	PAFZZ		PAFZZ			5940-00-557-1629	MANUFACTURE FROM TERMINAL,LUG MS25036-149	96906	A	EA 1	
6	12	PAFZZ	PAFZZ		PAFZZ			5940-00-113-8184	TERMINAL,LUG MS25036-150	96906	A	EA 1	
6	13	PAFZZ	PAFZZ		PAFZZ			6145-00-578-7519	WIRE ELECTRICAL 3 1/4IN REQUIRED MS5086-1-20-9	81349	A	FT V	
6	14	MFFFF	MFFZZ		MFFFF				LEAD,ELECTRICAL: TOGGLE SWITCH TO TERMINAL BOARD 13214E0157-3	97403	A	EA 1	
6	15	PAFZZ	PAFZZ		PAFZZ			5940-00-113-8179	MANUFACTURE FROM TERMINAL,LUG MS25036-107	96906	A	EA 2	
6	16	PAFZZ	PAFZZ		PAFZZ			6145-00-578-7517	WIRE,ELECTRICAL 5IN REQUIRED M5086-1-16-9	81349	A	FT V	
6	17	MFFFF	MFFZZ		MFFFF				LEAD,ELECTRICAL: CAPACITOR TO TERMINAL BOARD 13214E0157-5	97403	A	EA 1	
6	18	PAFZZ	PAFZZ		PAFZZ				MANUFACTURE FROM TERMINAL,LUG MS25036-149	96906	A	EA 1	
6	19	PAFZZ	PAFZZ		PAFZZ			5940-00-113-8184	TERMINAL,LUG MS25036-150	96906	A	EA 1	
6	20	PAFZZ	PAFZZ		PAFZZ			6145-00-578-7519	WIRE ELECTRICAL M5086-1-20-9	81349	A	FT V	

SECTION II. REPAIR PARTS LIST

(1) ILLUSTRATION A B FIG. ITEM NO. NO.	(2) SMR CODE A B ARMY FORCE		C	D	(3) USMC A B SSI REPL FACTOR		(4) NATIONAL STOCK NUMBER	(5) DESCRIPTION	MFR CODE	USABLE ON CODE	(6)	(7) QTY INC IN U/M UNITS	(8) USMC QTY PER EQUIP
	ARMY	FORCE			NAVY	USMC	REF NUMBER	REF NUMBER			U/M	EA	
6 21	MFFFF	MFFZZ		MFFFF				WIRING HARNESS CONTROL BOX REAR 13215E6097 MANUFACTURE FROM	97403	A	EA	1	
6 22	PAFZZ	PAFZZ		PAFZZ			5975-00-074-2072	STRAP, TIEDOWN, ELECTRICAL MS3367-1-9	96906	A	EA	2	
6 23	PAFZZ	PAFZZ		PAFZZ			5940-00-739-7463	TERMINAL, LUG 1561	83330	A	EA	2	
6 24	PAFZZ	PAFZZ		PAFZZ			5940-00-113-8179	TERMINAL LUG MS25036-107	96906	A	EA	10	
6 25	PAFZZ	PAFZZ		PAFZZ			5940-00-204-8966	TERMINAL, LUG MS25036-102	96906	A	EA	12	
6 26	PAFZZ	PAFZZ		PAFZZ			6145-00-578-7517	WIRE, ELECTRICAL M5086-1-16-9	81349	A	FT	V	
6 27	PAFZZ	PAFZZ		PAFZZ			6145-00-578-7519	WIRE, ELECTRICAL M5086-1-20-9	81349	A	FT	V	
6 28	MFFFF	MFFZZ		MFFFF				WIRING HARNESS CONTROL BOX, FRONT 1314E0155 MANUFACTURE FROM	97403	A	EA	1	
6 29	PAFZZ	PAFZZ		PAFZZ			5975-00-074-2072	STRAP, TIEDOWN, ELECTRICAL MS3367-1-9	96906	A	EA	4	
6 30	PAFZZ	PAFZZ		PAFZZ			5940-00-113-8179	TERMINAL, LUG MS25036-107	96906	A	EA	4	
6 31	PAFZZ	PAFZZ		PAFZZ			5940-00-204-8966	TERMINAL, LUG MS25036-102	96906	A	EA	10	
6 32	PAFZZ	PAFZZ		PAFZZ			5940-00-113-8184	TERMINAL, LUG MS25036-150	96906	A	EA	4	
6 33	PAFZZ	PAFZZ		PAFZZ			6145-00-578-7517	WIRE, ELECTRICAL M5086-1-16-9	81349	A	FT	V	
6 34	PAFZZ	PAFZZ		PAFZZ			6145-00-578-7519	WIRE, ELECTRICAL M5086-1-20-9	81349	A	FT	V	

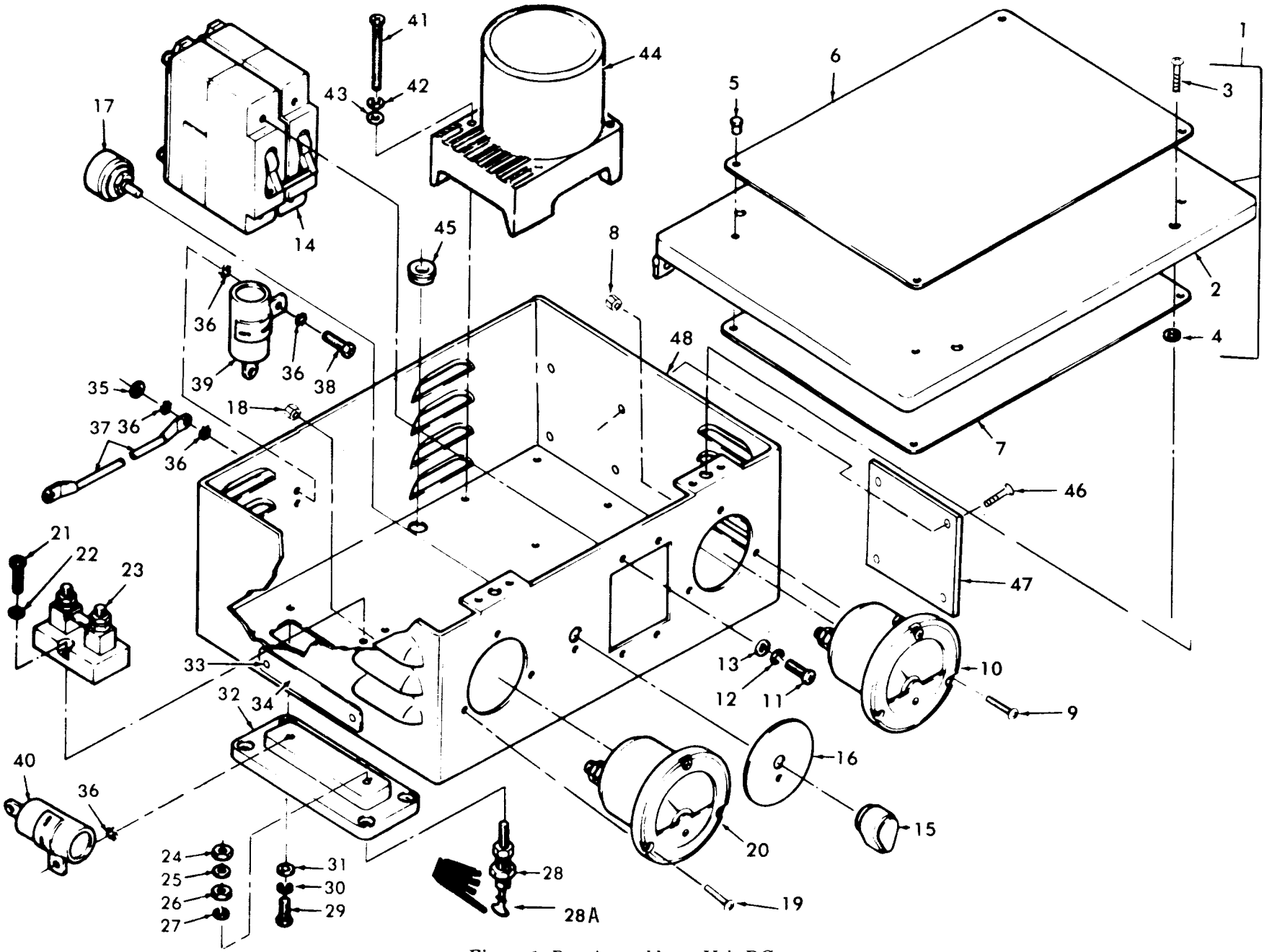

Figure 7. Box Assembly 28 Volt DC

SECTION II. REPAIR PARTS LIST

(1) ILLUSTRATION A B FIG. ITEM NO. NO.	(2) SMR CODE A B C D				(3) USMC A B SSI REPL FACTOR		(4) NATIONAL STOCK NUMBER	(5) DESCRIPTION REF NUMBER	MFR CODE	USABLE ON CODE	(6) U/M	(7) QTY INC IN UNITS	(8) USMC QTY PER EQUIP
	ARMY	AIR FORCE	NAVY	USMC	SSI	REPL FACTOR	REF NUMBER						
7	PBFHZ	AFFFF		XBFZZ			6110-00-904-5632	DISTRIBUTION BOX 13213E2750	97403	B	EA	1	
7	1	PBFZZ	XBFZZ		XBFZZ			BOX, CONTROL AND COVER ASSEMBLY 13217E1755	97403	B	EA	1	
7	2	PAFZZ	XBFZZ		XBFZZ		6110-00-116-2947	COVER, CONTROL BOX 13213E2751	97403	B	EA	1	
7	3	PAFZZ	PAOZZ		PAFZZ		5305-01-038-2566	SCREW, ASSEMBLED, WASHER NAS1301-10-8	80205	B	EA	2	
7	4	PAFZZ	PAOZZ		PAFZZ		5310-00-383-3658	NUT, SELF-LOCKING 132176E6402-10	97403	B	EA	2	
7	5	PAOZZ	XBFZZ		PAOZZ		5320-00-721-9075	RIVET, BLIND MS20604B3WZ	96906	B	EA	4	
7	6	PBOZZ	XBFZZ		XBOZZ		9905-00-760-3535	PLATE, INSTRUCTION 13208E8539	97403	B	EA	1	
7	7	PBOZZ	XBFZZ		XBOZZ			PLATE, INSTRUCTION 13213E2752	97403	B	EA	1	
7	8	PAOZZ	PAFZZ		PAOZZ		5310-00-836-3520	NUT, PLAIN, ASSEMBLED 69-561-1	30554	B	EA	3	
7	9	PAOZZ	PAFZZ		PAOZZ		5305-00-983-6730	SCREW, MACHINE MS35206-218	96906	B	EA	3	
7	10	PAOZZ	PAFBZ		PAFZZ		6625-00-068-0562	METER, POWER FACTOR CURRENT, DC 13208E8534	97403	B	EA	1	
7	11	PAFZZ	PAFZZ		PAFZZ		5305-00-984-4984	SCREW, MACHINE MS35206-227	96906	B	EA	4	
7	12	PAFZZ	PAFZZ		PAFZZ		5310-00-045-4007	WASHER, LOCK MS35338-41	96906	B	EA	4	
7	13	PAFZZ	PAFZZ		PAFZZ		5310-00-983-8483	WASHER, FLAT MS27183-5	96906	B	EA	4	
7	14	PAFZZ	PAFZZ		PAFZZ		5925-00-078-6376	CIRCUIT BREAKER 13208E8540	97403	B	EA	1	
7	15	PAOZZ	PAOZZ		PAOZZ		5355-00-959-3161	KNOB VARIABLE RESISTOR MS91528-OK1B	96906	B	EA	1	
7	16	PBOZZ	XBFZZ		XBOZZ		9905-00-057-6308	PLATE, INSTRUCTION VOLTAGE 13208E8464	97403	B	EA	1	
7	17	PAOZZ	PAFZZ		PAFZZ		5905-00-920-2706	RESISTOR, VARIABLE 12.5W, 1500 OHMS 13208E8460-1	97403	B	EA	1	
7	18	PAOZZ	PAFZZ		PAOZZ		4730-00-209-1561	CAP, TUBE 511-041800	78189	B	EA	3	
7	19	PAOZZ	PAFZZ		PAOZZ		5305-00-983-6730	SCREW, MACHINE MS35206-218	96906	B	EA	3	
7	20	PAOZZ	PAFBZ		PAOZZ		6625-00-078-6377	VOLTMETER 13208E8535	97403	B	EA	1	
7	21	PAOZZ	PAFZZ		PAOZZ		5305-00-984-6194	SCREW, MACHINE MS35206-246	96906	B	EA	2	
7	22	PAOZZ	PAFZZ		PAOZZ		5310-00-809-8544	WASHER, FLAT MS27183-7	96906	B	EA	2	
7	23	PAOZZ	PAFZZ		PAOZZ		6625-00-950-7699	SHUNT, INSTRUMENT 13213E2755	97403	B	EA	1	
7	24	PAOZZ	PAFZZ		PAOZZ		5310-00-247-7186	NUT, PLAIN, HEXAGON MS16203-37	96906	B	EA	2	

SECTION II. REPAIR PARTS LIST

(1) ILLUSTRATION A B FIG. ITEM NO. NO.	(2) SMR CODE A B ARMY AIR FORCE		C NAVY	D USMC	(3) USMC A B SSI REPL FACTOR		(4) NATIONAL STOCK NUMBER	(5) DESCRIPTION REF NUMBER	MFR CODE	USABLE ON CODE	(6) U/M	(7) QTY INC IN UNITS	(8) USMC QTY PER EQUIP
	A	B			A	B							
7	25	PAOZZ	PAFZZ		PAOZZ		5310-00-805-4864	WASHER, FLAT MS15795-511 96906	96906	B	EA	2	
7	26	PAOZZ	PAFZZ		PAOZZ		5310-00-584-7996	NUT, PLAIN, HEXAGON MS16203-25 96906	96906	B	EA	2	
7	27	PAOZZ	PAFZZ		PAOZZ		5310-00-889-2528	WASHER, LOCK MS45904-68 96906	96906	B	EA	2	
7	28	PAOZZ	PAFZZ		PAOZZ		5940-00-021-3321	TERMINAL, STUD 13208E5820-6 94703	94703	B	EA	2	
7	28A	PAOZZ					9505-00-248-9858	WIRE, NONELECTRICAL QQ-W-461 81348	81348	B	FT	2	
7	29	PAOZZ	PAFZZ		PAOZZ		5305-00-984-6194	SCREW, MACHINE INSULATOR MS35206-246 96906	96906	B	EA	4	
7	30	PAOZZ	PAFZZ		PAOZZ		5310-00-045-3299	WASHER, LOCK MS35338-42 96906	96906	B	EA	4	
7	31	PAOZZ	PAFZZ		PAOZZ		5310-00-809-8544	WASHER, FLAT MS27183-7 96906	96906	B	EA	4	
7	32	PAOZZ	PAFZZ		PAOZZ		5970-00-908-6471	INSULATOR, PLATE TERMINAL 13214E0154 97403	97403	B	EA	1	
7	33	PAOZZ	PAFZZ		PAOZZ		5320-00-721-9075	RIVET, BLIND MS20604B3W2 96906	96906	B	EA	2	
7	34	PBOZZ	XPFZZ		XBOZZ			NAMEPLATE LOAD TERMINAL 13208E8471 97403	97403	B	EA	1	
7	35	PAOZZ	PAFZZ		PAOZZ		5310-00-761-6882	NUT, PLAIN, HEXAGON MS51967-2 96906	96906	B	EA	1	
7	36	PAOZZ	PAFZZ		PAOZZ		5310-00-889-2528	WASHER, LOCK MS45904-68 96906	96906	B	EA	8	
7	37	PBOZZ	XBOZZ		XBOZZ		2590-00-944-6254	LEAD, ELECTRICAL 13208E5853-20 97403	97403	B	EA	1	
7	38	PAOZZ	PAFZZ		PAOZZ		5305-00-998-1725	SCREW, MACHINE MS35206-281 96906	96906	B	EA	1	
7	39	PAFZZ	PAFZZ		PAFZZ		5910-00-280-9988	CAPACITOR, FIXED, PAP, 5MFD, 100V DC CA32KB504 81349	81349	B	EA	1	
7	40	PAFZZ	PAFZZ		PAFZZ		5910-00-160-4802	CAPACITOR, FIXED, PAP, 5MFD, 100V DC CA33KFB504 81349	81349	B	EA	1	
7	41	PAFZZ	PAFZZ		PAFZZ		5305-00-984-6199	SCREW, MACHINE MS35206-251 96906	96906	B	EA	4	
7	42	PAFZZ	PAFZZ		PAFZZ		5310-00-045-3299	WASHER, LOCK MS35338-42 96906	96906	B	EA	4	
7	43	PAFZZ	PAFZZ		PAFZZ		5310-00-809-8544	WASHER, FLAT MS27183-7 96906	96906	B	EA	4	
7	44	PAFZZ	PAFZZ		PAFZZ		6110-00-903-4768	REGULATOR, VOLTAGE 13214E0260 97403	97403		EA	1	
7	45	PAFZZ	PAFZZ		PAFZZ		5325-00-276-6089	GROMMET, NONMETALLIC CONTROL BOX MS35490-16 96906	96906	B	EA	1	
7	46	PAOZZ	PAFZZ		PAOZZ		5320-00-721-9075	RIVET, BLIND MS20604B3W2 96906	96906	B	EA	4	
7	47	PBOZZ	XBFZZ		XBOZZ		9905-01-147-3474	PLATE, IDENTIFICATION 73-0506-6 30554		B	EA	1	
7	48	PFBZZ	XBFZZ		XAFZZ		6110-00-477-3197	CONTROL BOX, GENERATOR 13213E2753 97403	97403	B	EA	1	

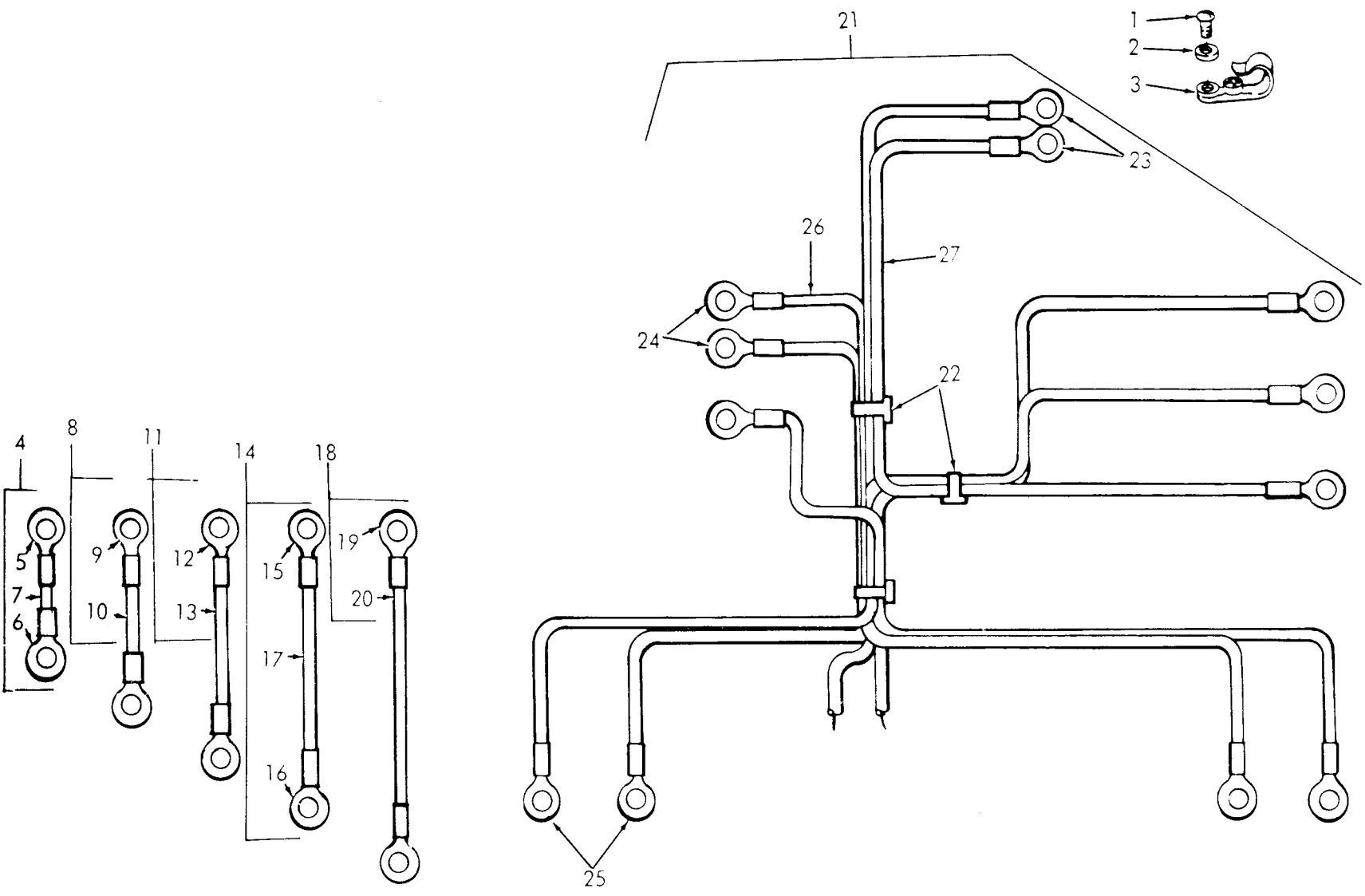

Figure 8. Wiring Harness 28 Volt DC

SECTION II. REPAIR PARTS LIST

(1) ILLUSTRATION		(2) SMR CODE				(3) USMC		(4) NATIONAL STOCK NUMBER	(5) DESCRIPTION		(6) USABLE ON CODE	(7) QTY INC IN U/M UNITS	(8) USMC QTY PER EQUIP
A	B	A	B	C	D	A	B						
FIG.	ITEM	ARMY	AIR FORCE	NAVY	USMC	SSI	REPL FACTOR	REF NUMBER		MFR CODE			
8	1	PAFZZ	PAFZZ		PAFZZ			5305-00-984-6193	SCREW,MACHINE NO: SIZE 5/8IN LG MS35206-245	96906	B	EA 3	
8	2	PAFZZ	PAFZZ		PAFZZ			5310-00-809-8544	WASHER,FLAT: STRAP MTG, NO MS27183-7	96906	B	EA 3	
8	3	PAFZZ	XBFZZ		PAFZZ			5975-00-906-2414	STRAP,TIEDOWN,ELECTRICAL 13208E8536	97403	B	EA 3	
8	4	MFFFF	MFFZZ		MFFFF				LEAD,ELECTRICAL CAPACITOR TO TERMINAL BOARD 1321450157-9	97403	B	EA 1	
8	5	PAFZZ	PAFZZ		PAFZZ			5940-00-113-8184	MANUFACTURE FROM TERMINAL,LUG MS25036-150	96906	B	EA 1	
8	6	PAFZZ	PAFZZ		PAFZZ			5940-00-557-1629	TERMINAL,LUG MS25036-149	96906	B	EA 1	
8	7	PAFZZ	PAFZZ		PAFZZ			6145-00-578-7519	WIRE,ELECTRICAL 3IN REQUIRED M5086-1-20-9	81349	B	FT V	
8	8	MFFFF	MFFZZ		MFFFF				LEAD,ELECTRICAL,CIRCUIT BREAKER TO GROUND TERMINAL 13214E0157-6	97403	B	EA 1	
8	9	PAFZZ	PAFZZ		PAFZZ			5940-00-143-4777	TERMINAL,LUG MS25036-157 MANUFACTURE FROM	96906	B	EA 2	
8	10	PAFZZ	PAFZZ		PAFZZ			6145-00-003-9527	WIRE,ELECTRICAL 3 3/4IN REQUIRED M5086-1-10-9	81349	B	FT V	
8	11	MFFFF	MFFZZ		MFFFF				LEAD,ELECTRICAL CIRCUIT BREAKER TO SHUNT 13214E0157-8 MANUFACTURE FROM	97403	B	EA 1	
8	12	PAFZZ	PAFZZ		PAFZZ			5940-00-143-4777	TERMINAL,LUG MS25036-157	96906	B	EA 2	
8	13	PAFZZ	PAFZZ		PAFZZ			6145-00-003-9527	WIRE,ELECTRICAL 4 1/2IN REQUIRED M5086-1-10-9		B	FT V	
8	14	MFFFF	MFFZZ		MFFFF				LEAD ELECTRICAL CAPACITOR TO TERMINAL BOARD 13214E0157-10 MANUFACTURE FROM	97403	B	EA 1	
8	15	PAFZZ	PAFZZ		PAFZZ			5940-00-113-8184	TERMINAL,LUG MS25036-150	96906	B	EA 1	
8	16	PAFZZ	PAFZZ		PAFZZ			5940-00-557-1629	TERMINAL,LUG MS25036-149	96906	B	EA 1	
8	17	PAFZZ	PAFZZ		PAFZZ			6145-00-578-7519	WIRE,ELECTRICAL 4 7/8IN REQUIRED M5086-1-20-9		B	FT V	
8	18	MFFFF	MFFZZ		MFFFF				LEAD,ELECTRICAL CIRCUIT BREAKER TO GROUND TERMINAL 13214E0157-7	97403	B	EA 1	

SECTION II. REPAIR PARTS LIST

(1) ILLUSTRATION		(2) SMR CODE				(3) USMC			(4) NATIONAL	(5) DESCRIPTION	(6) USABLE	(7) QTY	(8) USMC
A	B	A	B	C	D	A	B	STOCK		ON	INC	QTY	
FIG.	ITEM	ARMY	AIR	NAVY	USMC	SSI	REPL	NUMBER	REF NUMBER	CODE	U/M	PER	
NO.	NO.		FORCE				FACTOR					EQUIP	
									MANUFACTURE FROM				
8	19	PAFZZ	PAFZZ		PAFZZ			5940-00-143-4777	TERMINAL,LUG MS25036-157	96906	B	EA 2	
8	20	PAFZZ	PAFZZ		PAFZZ			6145-00-008-9527	WIRE,ELECTRICAL 6 3/4IN REQUIRED M5086-1-10-9		B	FT V	
8	21	MFFFF	MFFZZ		MFFFF				WIRING,HARNES CONTROL BOX 13213E2754 MANUFACTURE FROM	97403	B	EA 1	
8	22	PAFZZ	PAFZZ		PAFZZ			5975-00-074-2072	STRAP,TIEDOWN,ELECTRICAL MS3367-1-9	96906	B	EA 2	
8	23	PAFZZ	PAFZZ		PAFZZ			5940-00-557-1629	TERMINAL,LUG MS25036-149	96906	B	EA 2	
8	24	PAFZZ	PAFZZ		PAFZZ			5940-00-204-8966	TERMINAL,LUG MS25036-102	96906	B	EA 2	
8	25	PAFZZ	PAFZZ		PAFZZ			5940-00-113-8184	TERMINAL,LUG MS25036-150	96906	B	EA 8	
8	26	PAFZZ	PAFZZ		PAFZZ			6145-00-578-7517	WIRE,ELECTRICAL 1FT REQUIRED M5086-1-16-9	81349	B	FT 1	
8	27	PAFZZ	PAFZZ		PAFZZ			6145-00-578-7519	WIRE,ELECTRICAL 7FT REQUIRED M5086-1-20-9	81349	B	FT 7	

SECTION II. REPAIR PARTS LIST

(1) ILLUSTRATION A B FIG. ITEM NO. NO.	(2) SMR CODE A B C D ARMY FORCE NAVY USMC	(3) USMC A B SSI REPL FACTOR	(4) NATIONAL STOCK NUMBER	(5) DESCRIPTION REF NUMBER	(6) USABLE ON CODE	(7) QTY INC IN UNITS	(8) USMC QTY PER EQUIP
GROUP 05-GENERATOR ASSEMBLY 60 HZ							
9 1	PAFZZ PAFZZ	PAFZZ	5305-00-225-3839	SCREW,CAP,HEXAGON HEAD: GENERATOR MTG,1/4-20 THD SIZE,1 1/4IN LG MS90725-8	96906	EA	6
9 2	PAFZZ PAFZZ	PAFZZ	5310-00-582-5965	WASHER,LOCK: GENERATOR MTG, 1/4IN SCREW SIZE MS35338-44	96906	EA	6
9 3	PAFZZ PAFZZ	PAFZZ	5310-00-809-4058	WASHER,FLAT: GENERATOR MTG, 1/4IN SCREW SIZE MS27183-10	96906	EA	6
9	PBFDD PBFDD	PAFFF	6115-00-903-5395	GENERATOR ASSEMBLY: AC, 60 HERTZ 13214E0200	97403	A EA	1
9 4	PAFZZ PAFZZ	PAFZZ	5305-00-995-3440	SCREW,MACHINE: COVER MTG,FAN NO 10-32 THD SIZE, 1 3/4IN LG MS35207-271	96906	A EA	2
9 5	PAFZZ PAFZZ	PAFZZ	5310-00-045-3296	WASHER,LOCK: COVER MTG, NO 10 SCREW SIZE MS35338-43	96906	A EA	2
9 6	XBFZZ XBFZZ	XBFZZ	6115-00-859-2412	COVER,FAN 13205E5202	97403	A EA	1
9 7	PAFZZ PAFZZ	PAFZZ	5306-00-904-4118	BOLT,MACHINE: FAN MTG, 5/16-24 THD SIZE,6IN LG 13214E0205	97403	A EA	1
9 8	PAFZZ PAFZZ	PAFZZ	5310-00-407-9566	WASHER,LOCK: 5/16IN SCREW SIZE MS35338-45	96906	A EA	1
9 9	PAFZZ PAFZZ	PAFZZ	4140-00-490-6097	FAN,ELECTRICAL,ROTATING: GENERATOR COOLING 13205E5203	97403	A EA	1
9 10	PAFZZ PAFZZ	PAFZZ	5305-00-225-3839	SCREW,CAP,HEXAGON HEAD: MTG,ADAPTER TO HOUSING,1/4-20 THD SIZE, 1IN LG MS90725-8	96906	A EA	4
9 11	PAFZZ PAFZZ	PAFZZ	5310-00-582-5965	WASHER,LOCK: MTG,ADAPTER TO HOUSING,1/4IN SCREW SIZE MS35338-44	96906	A EA	4
9 12	PAFZZ XBFZZ	PAFZZ	6115-01-072-5663	BAFFLE,FAN 13205E5204	97403	A EA	1
9 13	PAFZZ PAFZZ	PAFZZ	5340-00-359-5269	CLIP,WIRE: LOCATING, ROTOR BEARING 13214E0209	97403	A EA	1
9 14	PAFDD PAFFF	PAFZZ	6115-00-903-4772	ROTOR ASSEMBLY 13214E0202	97403	A EA	1
9 15	PAFZZ PAFZZ	PAFZZ	3110-00-585-3296	BEARING,BALL: ROTOR, GENERATOR 13211E6807	97403	A EA	4
9 16	PAFZZ PAFZZ	PAFZZ	5305-00-984-6222	SCREW,MACHINE: RECTIFIER MTG,NO 6-32 THD SIZE, 1 1/4IN LG MS35206-235	96906	A EA	4
9 17	XAFZZ PAFZZ	PAFZZ	6130-00-910-6849	RECTIFIER,POSITIVE 13214E0215	97403	A EA	1
9 18	XAFZZ PAFZZ	PAFZZ	6130-00-910-6848	RECTIFIER,NEGATIVE 13214E0214	97403	A EA	1
9 19	PAFZZ PAFZZ	PAFZZ	5305-00-175-3230	SCREW,DRIVE: PLATE MTG, NO2 DIA,3/16IN LG MS21318-14	96906	A EA	2
9 20	XBOZZ XBFZZ	XBOZZ		PLATE,IDENTIFICATION: GENERATOR 13214E0229	97403	A EA	1
9 21	PAFDD PBFDD	PAFHH	6115-00-903-4769	HOUSING ASSEMBLY: GENERATOR 13214E0203	97403	A EA	1
9 22	PAFZZ PAFZZ	PAFZZ	5325-00-279-1248	GROMMET,RUBBER: CABLE, GENERATOR HOUSING MS35489-103	96906	A EA	1

SECTION II. REPAIR PARTS LIST

(1) ILLUSTRATION		(2) SMR CODE				(3) USMC		(4) NATIONAL	(5) DESCRIPTION		(6) USABLE	(7) QTY	(8) USMC
A	B	A	B	C	D	A	B	STOCK		ON	INC	QTY	
FIG.	ITEM	ARMY	AIR	NAVY	USMC	SSI	REPL	NUMBER	REF NUMBER	CODE	U/M	PER	
NO.	NO.		FORCE			FACTOR						EQUIP	
9	23	PAFZZ	XBFZZ		PAFZZ			5940-00-204-8966	TERMINAL LUG MS25036-102	96906	A	EA 6	
9	24	XADDD	PAFZZ		PAHZZ			6115-00-903-4770	STATOR, ALTERNATOR 13214E0241	97403	A	EA 1	
9	25	XADDD	PAFZZ		PAHZZ			6115-00-903-4771	STATOR, EXCITER 13214E0242	97403	A	EA 1	
9	26	XADDD	XAFZZ		XAFZZ				HOUSING, GENERATOR 13214E0240	97403	A	EA 1	
9	27	PAFZZ	PAFZZ		PAFZZ			6115-00-999-0889	ADAPTER: MTG, GENERATOR TO ENGINE 13214E0201	97403	A	EA 1	
9	28	PAOZZ	XBFZZ		PAOZZ			5306-00-057-6306	EYE BOLT: LIFTING, GENERATOR SET 13208E8458	97403		EA 1	
9	29	PAFZZ	PAFZZ		PAFZZ			5306-00-225-9088	BOLT, MACHINE: GENERATOR ADAPTER, MTG, 5/16-24 THD SIZE, 7/8IN LG MS90726-33	96906		EA 4	
9	30	PAFZZ	PAFZZ		PAFZZ			5310-00-407-9566	WASHER, LOCK: GENERATOR ADAPTER, MTG, 5/16IN SCREW SIZE MS35338-45	96906		EA 1	
9	31	PAFZZ	PAFZZ		PAFZZ			5310-00-081-4219	WASHER, FLAT: GENERATOR ADAPTER MTG, 5/16IN SCREW SIZE MS27183-12	96906		EA 4	

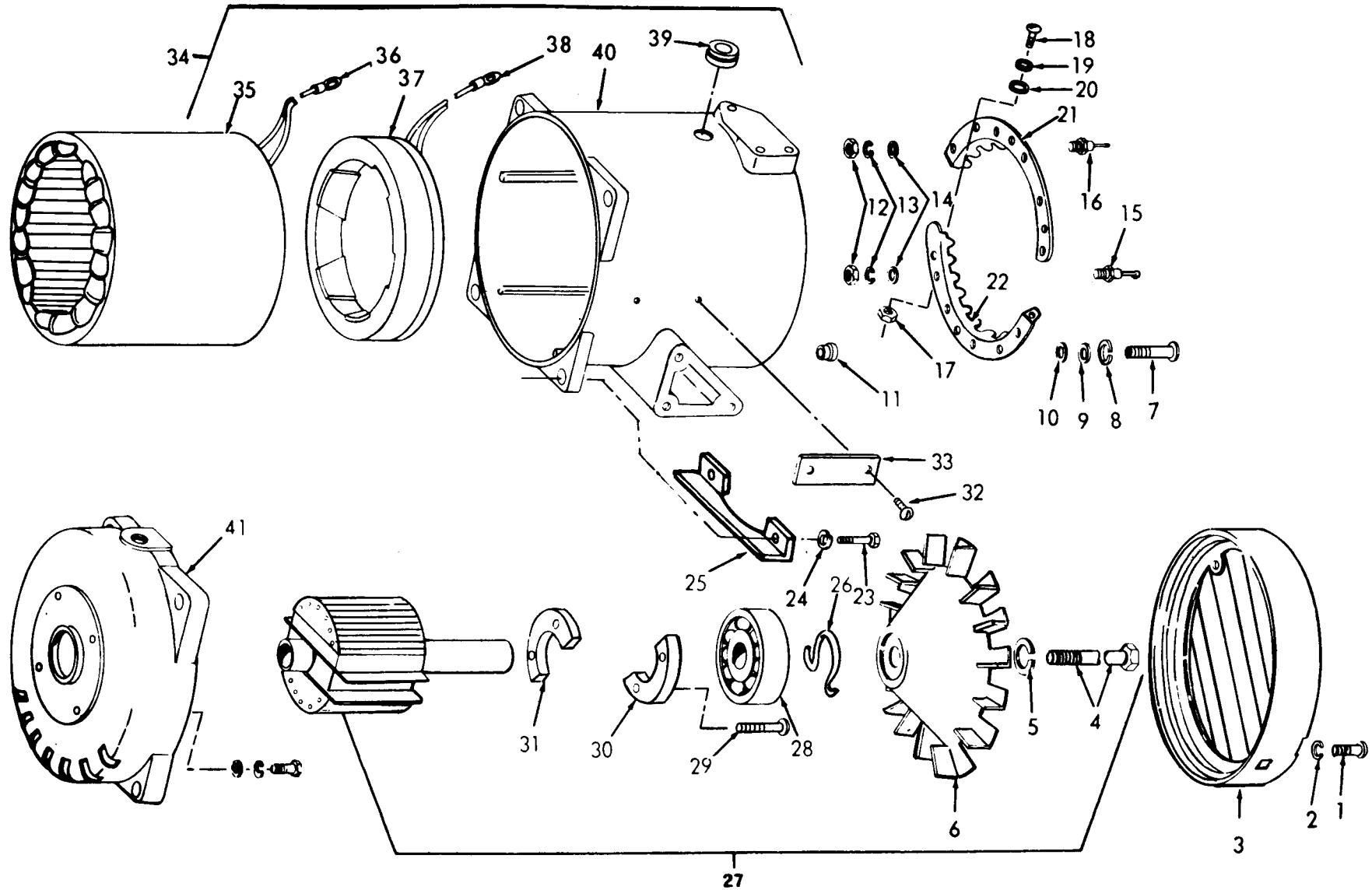

Figure 10. Generator Assembly 28-Volt DC

SECTION II. REPAIR PARTS LIST

(1) ILLUSTRATION A B FIG. ITEM NO. NO.	(2) SMR CODE A B C D ARMY AIR FORCE NAVY USMC	(3) USMC A B SSI REPL FACTOR	(4) NATIONAL STOCK NUMBER	(5) DESCRIPTION REF NUMBER	MFR CODE	USABLE ON CODE	(6) QTY INC IN U/M	(7) USMC QTY PER EQUIP
10	PBFFF PBFFF	PAFZZ	6115-00-926-0813	GENERATOR, DIRECT CURRENT: DC, 28V 13213E2800	97403	B	EA	1
10	1 PAFZZ PAFZZ	PAFZZ	5305-00-995-6311	SCREW, MACHINE MS35207-271	96906	B	EA	2
10	2 PAFZZ PAFZZ	PAFZZ	5310-00-045-3296	WASHER, LOCK MS35338-43	96906	B	EA	2
10	3 PBFZZ XBFZZ	XBFZZ	6115-00-859-2412	COVER, VENTILATORY 13205E5202	97403	B	EA	1
10	4 PAFZZ PAFZZ	PAFZZ	5306-00-225-9107	BOLT, MACHINE ROTOR FAN MS90726-52	96906	B	EA	1
10	5 PAFZZ PAFZZ	PAFZZ	5310-00-407-9566	WASHER, LOCK MS35338-45	96906	B	EA	5
10	6 PAFZZ PAFZZ	PAFZZ	6115-00-903-5396	IMPELLER, FAN, AXIAL 13214E0204	97403	B	EA	1
10	7 PAFZZ PAFZZ	PAFZZ	5305-00-993-1851	SCREW, MACHINE MS35207-267	96906	B	EA	6
10	8 PAFZZ PAFZZ	PAFZZ	5310-00-045-3296	WASHER, LOCK MS35338-43	96906	B	EA	6
10	9 PAFZZ PAFZZ	PAFZZ	5310-00-809-8546	WASHER, FLAT MS27183-8	96906	B	EA	6
10	10 PAFZZ PAFZZ	PAFZZ	5970-00-177-1625	INSULATOR BUSHING 13213E2805	97403	B	EA	6
10	11 PAFZZ PAFZZ	PAFZZ	5970-00-466-2118	INSULATOR, BUSHING 13213E2804	97403	B	EA	6
10	12 PAFZZ PAFZZ	PAFZZ		NUT, PLAIN, HEXAGON FF-N-836-TYPE II STYLE 4 1/4-28	81348	B	EA	10
10	13 PAFZZ PAFZZ	PAFZZ	5310-00-550-1130	WASHER, LOCK & CONDUCTOR INTERNAL TEETH MS35333-40	96906	B	EA	10
10	14 PAFZZ PAFZZ	PAFZZ		WASHER, FLAT FF-W-92 TYPE A GRI-CL-E.281D	81348	B	EA	10
10	15 PAFZZ PAFZZ	PAFZZ	5961-00-955-5359	SEMI-CONDUCTOR DEVICE, DIODE 13213E2803-2	97403	B	EA	5
10	16 PAFZZ PAFZZ	PAFZZ	5961-00-915-5460	SEMICONDUCTOR DEVICE, DIODE 132313E2803-1	97403	B	EA	5
10	17 PAFZZ PAFZZ	PAFZZ	5310-00-410-3025	NUT, PLAIN, HEXAGON MS35650-305T	96906	B	EA	2
10	18 PAFZZ PAFZZ	PAFZZ		SCREW, MACHINE FF-S-92 TYPIII STY	81348	B	EA	2
10	19 PAFZZ PAFZZ	PAFZZ	5310-00-576-5752	WASHER, LOCK MS35333-39	96906	B	EA	2
10	20 PAFZZ PAFZZ	PAFZZ	5310-00-401-1967	WASHER, FLAT AN961-10S	88044	B	EA	2
10	21 XBFZZ XBFZZ	XBFZZ		HEAT SINK, POSITIVE 13213E2806-1	97403	B	EA	1

SECTION II. REPAIR PARTS LIST

(1) ILLUSTRATION A FIG. NO.	(2) SMR CODE A B ARMY AIR FORCE	C	D	(3) USMC		(4) NATIONAL STOCK NUMBER	(5) DESCRIPTION REF NUMBER	MFR CODE	USABLE ON CODE	(6) QTY INC IN U/M	(7) QTY PER EQUIP	(8) USMC QTY PER EQUIP
				A	B							
10	22	XBFZZ	XBFZZ		XBFZZ		HEAT SINK,NEGATIVE 13213E2806-2	97403	B	EA	1	
10	23	PAFZZ	PAFZZ		PAFZZ	5305-00-225-3839	SCREW,CAP,HEXAGON HEAD MS90725-8	96906	B	EA	4	
10	24	PAFZZ	PAFZZ		PAFZZ	5310-00-582-5965	WASHER,LOCK: MTG ADAPTER TO HOUSING MS35338-44	96906	B	EA	4	
10	25	PAFZZ	PAFZZ		PAFZZ	6115-01-072-5663	BAFFLE,FAN 13205E5204	97403	B	EA	1	
10	26	PAFZZ	PAFZZ		PAFZZ	5340-00-359-5269	CLIP,WIRE: LOCATING,ROTOR BEARING 13214E0209	97403	B	EA	1	
10	27	PAFFF	PAFZZ		PAFZZ	6115-00-903-4772	ROTOR ASSEMBLY 13214E0202	97403	B	EA	1	
10	28	PAFZZ	PAFZZ		PAFZZ	3110-00-585-3296	BEARING,BALL: ROTOR GENERATOR 13211E6807	97403	B	EA	1	
10	29	PAFZZ	PAFZZ		PAFZZ	5305-00-984-6222	SCREW,MACHINE: RECTIFIER MTG MS35206-235	96906	B	EA	4	
10	30	PAFZZ	PAFZZ		PAFZZ	6130-00-910-6849	RECTIFIER,POSITIVE 13214E0215	97403	B	EA	1	
10	31	PAFZZ	PAFZZ		PAFZZ	6130-00-910-6848	RECTIFIER,NEGATIVE 13214E0214	97403	B	EA	1	
10	32	PAFZZ	PAFZZ		PAFZZ	5305-00-175-3230	SCREW,DRIVE,PLATE MTG MS21318-14	96906	B	EA	2	
10	33	XBOZZ	XBFZZ		XBOZZ		PLATE,IDENTIFICATION: GENERATOR 13213E2807	97403	B	EA	1	
10	34	PAFHH	PBFFF		PAFHH	6115-00-910-6847	HOUSING ASSEMBLY: GENERATOR 13213E2801	97403	B	EA	1	
10	35	XAFZZ	PAFZZ		PAHZZ	6115-00-910-6846	STATOR,WOUND 13213E2802	97403	B	EA	1	
10	36	PAFZZ	PAFZZ		PAFZZ	5940-00-204-8966	TERMINAL,LUG MS25036-102	96906	B	EA	4	
10	37	XAFZZ	PAFZZ		PAHZZ	6115-00-903-4771	STATOR,EXCITER 13214E0242	97403	B	EA	1	
10	38	PAFZZ	PAFZZ		PAFZZ	5940-00-143-4777	TERMINAL,LUG MS25036-157	96906	B	EA	2	
10	39	PAFZZ	PAFZZ		PAFZZ	5325-00-279-1248	GROMMET,RUBBER: CABLE, GENERATOR HOUSING MS35489-103	96906	B	EA	1	
10	40	XAFZZ	XAFZZ		XAFZZ	6115-01-207-1881	HOUSING,GENERATOR 13214E0240	97403	B	EA	1	
10	41	PAFZZ	PAFZZ		PAFZZ	6115-00-999-0889	ADAPTER: MTG,GENERATOR TO ENGINE 13214E0201	97403	B	EA	1	

32 CHANGE 1

SECTION II. REPAIR PARTS LIST

(1) ILLUSTRATION		(2) SMR CODE				(3) USMC		(4) NATIONAL STOCK NUMBER	(5) DESCRIPTION	(6) USABLE ON CODE	(7) QTY INC IN UNITS	(8) USMC QTY PER EQUIP
A	B	A	B	C	D	A	B					
FIG.	ITEM	ARMY	AIR FORCE	NAVY	USMC	SSI	REPL FACTOR		REF NUMBER	MFR CODE		
NO.	NO.											
GROUP 06-BULK MATERIAL												
BULK		PAFZZ	PAFZZ		PAFZZ				CHAIN RRC271	81348		FT V
BULK		PAFZZ	PAFZZ		PAFZZ			6145-00-578-7513	WIRE,ELECTRICAL M5086-1-10-9	81349		FT V
BULK		PAFZZ	PAFZZ		PAFZZ			6145-00-578-7517	WIRE,ELECTRICAL M5086-1-16-9	81349		FT V
BULK		PAFZZ	PAFZZ		PAFZZ			6145-00-578-7519	WIRE,ELECTRICAL M5086-1-20-9	81349		FT V
BULK		MOOZZ	MOOZZ		MOOZZ			9505-00-596-1668	WIRE, NON-ELECTRICAL, 0.51 INCH DIAMETER			FT V
BULK		MOOZZ	MOOZZ		MOOZZ			9505-00-804-3814	WIRE, NON-ELECTRICAL, 0.51 INCH DIAMETER			FT V

**Section IV. INDEX-NATIONAL STOCK NUMBER AND REFERENCE NUMBER
CROSS-REFERENCE TO FIGURE AND ITEM NUMBER**

STOCK NUMBER	FIG.	ITEM	STOCK NUMBER	FIG.	ITEM
2590-00-944-6254	5	25	5305-00-984-6197	54	5
	7	37	5305-00-984-6198	17	3
2805-00-072-4871	1	11		4	4
2910-00-065-6793	3	5	5305-00-984-6199	60	5
2910-00-401-4264	3	27	5305-00-984-6199	7	41
2910-00-485-6937	3	21	5305-00-984-6210	3	18
2910-00-904-2645	3	1	5305-00-984-6222	9	16
	3	4		10	29
2990-00-065-6794	1	4	5305-00-988-1725	5	24
	9	15		5	48
3110-00-585-3296	10	28	5305-00-993-1851	10	7
4010-00-160-0183	3	3	5305-00-995-3440	9	4
4010-00-267-9618	3	9	5305-00-995-6311	10	1
4030-00-270-5436	3	2	5305-00-998-1725	7	38
	3	8	5306-00-057-3066	9	28
4140-00-490-6097	9	9	5306-00-225-9088	9	29
4720-00-857-1732	3	12	5306-00-225-9107	10	4
4730-00-006-1465	3	22	5306-00-904-4118	9	7
4730-00-209-1561	3	7	5310-00-045-3296	3	19
	7	18		9	5
4730-00-277-7910	3	14		10	2
4730-00-287-1032	3	23		10	8
4730-00-595-1074	3	6	5310-00-045-3299	4	2
4730-00-767-2615	3	10		5	40
	3	22		5	45
4730-00-889-2474	3	13		5	55
4820-00-925-7374	3	15		5	61
5305-00-068-0501	4	7		7	30
5305-00-068-0502	1	10		7	42
5305-00-068-0504	3	24	5310-00-045-4007	5	28
5305-00-071-2239	1	7		7	12
	2	10	5310-00-060-2039	3	16
5305-00-083-6645	5	3	5310-00-081-4219	9	31
	7	3	5310-00-187-2425	2	2
5305-00-175-3230	2	5		5	35
	2	12	5310-00-247-7186	7	24
	9	19	5310-00-383-3658	5	4
	10	32		7	4
5305-00-225-3839	9	1	5310-00-401-1967	10	20
	9	10	5310-00-407-9566	9	8
	10	23		9	30
5305-00-267-8974	1	6		10	5
5305-00-958-5450	5	29	5310-00-410-3025	10	17
5305-00-983-6730	5	9	5310-00-550-1130	10	13
	5	12	5310-00-576-5752	10	19
	7	9	5310-00-582-5965	1	2
	7	19		1	8
5305-00-984-4984	7	11		3	25
5305-00-984-4992	5	51		3	29
5305-00-964-6191	5	43		4	8
5305-00-984-6193	6	1		9	2
	8	1		9	11
5305-00-964-6194	39	5		10	24
	21	7			
	29	7			

SECTION IV. INDEX-NATIONAL STOCK NUMBER AND REFERENCE NUMBER
CROSS-REFERENCE TO FIGURE AND ITEM NUMBER

STOCK NUMBER	FIG. NO.	ITEM NO.	STOCK NUMBER	FIG. NO.	ITEM NO.
5310-00-584-7995	5	34	5325-00-279-1248	9	22
5310-00-584-7996	2	1		10	39
	5	36	5325-00-282-7471	5	70
	7	26	5325-00-432-9796	5	67
5310-00-761-6882	5	21	5330-00-797-3506	1	5
	5	47	5340-00-359-5269	9	13
5310-00-761-6882	7	35		10	26
5310-00-768-0319	7	7	5340-00-467-2550	4	12
5310-00-805-4864	2	3	5340-00-905-1679	2	10
	5	37	5355-00-959-3161	7	15
	7	25	5905-00-920-2706	7	17
5310-00-809-4058	1	3	5905-00-948-2116	5	15
	1	9	5910-00-160-4802	7	40
	3	26	5910-00-280-9988	7	39
	3	30	5910-00-504-7418	5	23
	4	9	5910-00-801-3483	5	50
	5	16	5925-00-078-6378	7	14
	9	3	5930-00-557-5175	5	58
5310-00-809-8544	4	5	5930-00-655-4247	5	18
	5	41	5940-00-021-3321	2	4
	5	44		7	28
	5	56	5940-00-113-8179	6	5
	5	62		6	8
	6	2		6	15
	7	22		6	24
	5	31		6	30
	7	43	5940-00-113-8184	6	12
	8	2		6	19
5310-00-809-8546	3	20		6	32
	10	9		8	5
5310-00-822-8525	5	68		8	15
5310-00-836-3520	5	8		8	25
	5	11	5940-00-143-4777	8	9
	7	8		8	12
5310-00-845-7769	5	69		8	19
5310-00-857-4957	2	7		10	38
5310-00-889-2528	5	22	5940-00-204-8966	6	25
	5	49		6	31
	7	27		8	24
	7	36		9	23
5310-00-934-9747	5	27		10	36
5310-00-934-9757	4	1	5940-00-557-1629	6	11
5310-00-983-8483	5	30		8	6
	5	52		8	16
	7	13		8	23
5320-00-118-1995	4	11	5940-00-739-7463	6	23
5320-00-721-9075	5	5	5940-00-958-0349	2	4
	5	32		5	38
	5	64	5961-00-915-5460	10	16
	7	5	5961-00-955-5359	10	15
	7	33	5970-00-177-1625	10	10
	7	46	5970-00-466-2118	10	11
5325-00-6089	7	45	5970-00-908-6471	5	42
5325-00-276-6100	5	20		7	32

SECTION IV. INDEX-NATIONAL STOCK NUMBER AND REFERENCE NUMBER
CROSS-REFERENCE TO FIGURE AND ITEM NUMBER

STOCK NUMBER	FIG. NO.	ITEM NO.	STOCK NUMBER	FIG. NO.	ITEM NO.
5975-00-074-2072	6	22	6130-00-910-6846	9	18
	6	29		10	31
	8	22	6130-00-910-6849	9	17
5975-00-844-1066	5	26		10	30
5975-00-906-2414	6	3	6145-00-003-9527	8	10
5975-00-906-2414	8	3		8	13
6110-00-116-2947	7	2		8	20
6110-00-453-8971	5	7	6145-00-578-7513	BULK	
6110-00-477-3197	7	48	6145-00-578-7517	6	6
6110-00-903-4758	5	63		6	9
	7	44		6	16
6110-00-904-5631	5			6	26
6110-00-904-5632	7			6	33
6110-00-035-0427	5	1		8	26
6115-00-522-3993	4	10	6145-00-578-7517	BULK	
6115-00-859-2412	9	6	6145-00-578-7519	6	13
	10	3		6	20
6115-00-903-4769	9	21		6	27
6115-00-903-4770	9	24		6	34
6115-00-903-4771	9	25		8	7
	10	37		8	17
6115-00-903-4772	9	14		8	27
	10	27	6145-00-578-7519	BULK	
6115-00-903-5395	9		9505-00-248-9858	7	28A
6115-00-903-5396	10	6	9505-00-304-3814	5	38A
6115-00-910-6845	5	57	9905-00-596-1668	BULK	
6115-00-910-6846	10	35	9905-00-804-3814	BULK	
6115-00-910-6847	10	34	6625-00-078-6377	7	20
6115-00-921-6880	2	14	6625-00-950-7699	7	23
6115-00-921-6881	2	11	6625-00-054-2038	5	10
6115-00-926-0813	10		6625-00-065-5301	5	13
6115-00-940-0175	5	46	6625-00-068-0562	7	10
6115-00-999-0889	9	27	9905-00-057-6308	5	17
	10	41		7	16
6115-01-072-5663	9	12	9905-00-079-8369	2	13
	10	25	9905-00-140-1162	5	33
6115-01-207-1881	10	40	9905-00-256-2138	5	19
			9905-00-421-1300	5	6
			9905-00-477-4137	2	6
			9905-00-760-3535	7	6
			9905-01-147-3474	7	47
			9905-01-147-3718	5	65

SECTION IV. INDEX-NATIONAL STOCK NUMBER AND REFERENCE NUMBER
CROSS-REFERENCE TO FIGURE AND ITEM NUMBER

REFERENCE NO.	MFG. CODE	FIG. NO.	ITEM NO.	REFERENCE NO.	MFG. CODE	FIG. NO.	ITEM NO.
AN931-8-13	88044	5	20	MS25036-150	96906	6	12
AN961-10S	88044	10	20			6	19
CA32KFB504	81349	7	39			6	32
CA33KFB504	81349	7	40			8	5
CA36KFW104	81349	5	23			8	15
CA38KFW104	81349	5	50			8	25
FF-N-836-TYPE II SYSTEM 1/4-28	81348	10	12	MS25036-157	96906	8	9
FF-S-92TYPIII STY9C	81348	10	18			8	12
DESI 10-32						8	19
FF-W-92TYPE A	81348	10	14	MS25126E3	96906	5	58
GRI-CL-E,281 ID				MS27053-4C	96906	3	13
MIL-H-27267-4	81349	3	12	MS27183-10	96906	1	3
MS157-95-511	96906	2	3			1	9
		5	37			3	26
		7	25			3	30
MS16203-25	96906	2	1			4	9
		5	36			5	16
		7	26	MS27183-12	96906	9	31
MS16203-27	96906	5	34	MS27183-5	96906	5	30
MS16203-37	96906	7	24			5	52
MS20470B4-6	96906	4	11			7	13
MS20604B3W2	96906	5	5	MS27183-7	96906	4	5
		5	32			5	41
		5	64			5	44
		7	5			5	56
		7	33			5	62
		7	46			6	2
MS20822-4B	96906	3	23			7	22
MS20913-1J	96906	3	6			7	31
MS21044D6	96906	2	7			7	43
MS21044D08	96906	3	16			8	2
MS21318-14	96906	2	5	MS27183-8	96906	3	20
		2	12			10	9
		9	19	MS27183-10	96906	9	3
		10	32	MS27183-12	96906	9	6
MS24524-22	96906	5	18	MS3367-1-9	96906	6	22
MS25036-102	96906	6	25			6	29
		6	31			8	22
		8	24	MS35190-240	96906	5	29
		9	23	MS35206-218	96906	5	9
		10	36			5	12
MS25036-107	96906	6	5			7	9
		6	8			7	19
		6	15	MS35206-227	96906	7	11
		6	24	MS35206-232	96906	5	51
		6	30	MS35206-235	96906	10	29
MS25036-149	96906	6	11	MS35206-243	96906	5	43
		6	18	MS35206-245	96906	6	1
		8	6			8	1
		8	16				
		8	23				

SECTION IV. INDEX-NATIONAL STOCK NUMBER AND REFERENCE NUMBER
CROSS-REFERENCE TO FIGURE AND ITEM NUMBER

REFERENCE NO.	MFG. CODE	FIG. NO.	ITEM NO.	REFERENCE NO.	MFG. CODE	FIG. NO.	ITEM NO.
MS35206-246	96906	5	39	MS51872-105	96906	3	22
		7	21	MS51967-2	96906	5	21
		7	29			5	47
MS35206-249	96906	5	54			7	35
MS35206-250	96906	3	17	MS51968-2	96906	1	1
		4	4	MS87006-3	96906	3	2
MS35206-251	96906	5	60			3	8
		7	41	MS90725-12	96906	1	7
MS35206-263	96906	3	18	MS90725-5	96906	4	7
MS35206-281	96906	5	24			1	7
		5	48	MS90725-8	96906	9	1
		7	38			9	10
MS35207-267	96906	10	7			10	23
MS35207-271	96906	9	4	MS90726-3	96906	3	24
		10	1	MS90726-8	96906	1	6
MS35333-39	96906	10	19	MS90726-33	96906	9	29
MS35333-40	96906	10	13	MS90726-52	96906	10	4
MS35333-43	96906	3	19	MS90728-6	96906	1	10
		10	2	MS90728-12	96906	3	28
MS35338-41	96906	5	28	MS91528-OK1B	96906	7	15
		7	12	MS91528PK1B	96906	5	14
MS35338-42	96906	4	2	M5086-1-10-9	81349	8	10
		5	40			8	13
		5	45			8	20
		5	55				BULK
		5	61	M5086-1-16-9	81349	6	6
		7	30			6	9
		7	42			6	16
MS35338-43	96906	9	5			6	26
		10	8			6	33
MS35338-44	96906	1	2			8	26
		1	8				BULK
		3	25	M5086-1-20-9	81349	6	13
		3	29			6	20
		4	8			6	27
		9	2			6	34
		9	11			8	7
		10	24			8	17
		9	8			8	27
		9	30				BULK
MS35338-120	96906	10	5	NAS1301C10-B	80205	5	3
		2	2			7	3
MS35489-103	96906	5	35	NAS1455-00-8C	80205	3	3
		9	22			3	9
MS35490-1-6	96906	10	39				BULK
		7	45	QQ-W-423	81348	5	38A
MS35649-262	96906	5	27	QQ-W-461	81348	7	28A
MS35649-282	96906	4	1	WC00596	81348	5	31
MS35650-305T	96906	10	17	13205E5202	97403	9	6
MS39298	96906	1	11			10	3
MS45904-68	96906	5	22	13205E5202	97403	9	9
		5	49			9	12
		7	27	13205E5204	97403	10	25
MS45904-68	96906	7	36	13208E5768	97403	3	15
				13208E5820-2	97403	2	4
						5	38

SECTION IV. INDEX-NATIONAL STOCK NUMBER AND REFERENCE NUMBER
CROSS-REFERENCE TO FIGURE AND ITEM NUMBER

REFERENCE NO.	MFG. CODE	FIG. NO.	ITEM NO.	REFERENCE NO.	MFG. CODE	FIG. NO.	ITEM NO.
13208E5820-6	97403	2	4	13214E0108	97403	2	8
		7	28	13214E0109	97403	2	10
13208E5845	97403	3	5	13214E0110	97403	3	31
13208E5845	97403	5	67	13214E0115	97403	3	1
13208E5853-20	97403	5	25	13214E0116	97403	3	21
		7	37	13214E0117	97403	4	10
13208E8456	97403	2	13	13214E0119	97403	4	3
13208E8458	97403	9	28	13214E0120	97403	4	6
13208E8459	97403	5	59	13214E0150	97403	5	
13208E8460-1	97403	7	17	13214E0151	97403	5	2
13208E8460-2	97403	5	15	13214E0152	97403	5	7
13208E8462	97403	5	19	13214E0153-1	97403	5	66
13208E9464	97403	5	17	13214E0154	97403	5	42
		7	16			7	32
13208E8465	97403	5	33	13214E0155	97403	6	28
13208E8471	97403	7	34	13214E0157-1	97403	6	4
13208E8525	97403	1	4	13214E0157-2	97403	6	7
13208E8529	97403	5	6	13214E0157-3	97403	6	14
13208E8534	97403	7	10	13214E0157-4	97403	6	10
13208E8535	97403	7	20	13214E0157-5	97403	6	17
13208E8536	97403	6	3	13214E0157-6	97403	8	8
		8	3	13214E0157-7	97403	8	18
13208E8539	97403	7	6	13214E0157-8	97403	8	11
13208E8540	97403	7	14	13214E0157-9	97403	8	4
13211E6730	97403	2	6	13214E0157-10	97403	8	14
13211E6807	97403	9	16	13214E0200	97403	9	
		10	28	13214E0201	97403	9	27
13211E6901	97403	5	46			10	41
13211E6905	97403	5	13	13214E0202	97403	9	14
13211E6992-1	97403	5	10			10	27
13213E0037-3	97403	4	12	13214E0203	97403	9	21
13213E2750	97403	7		13214E0204	97403	10	6
13213E2751	97403	7	2	13214E0205	97403	9	7
13213E2752	97403	7	7	13214E0209	97403	9	13
13213E2753	97403	7	48			10	26
13213E2754	97403	8	21	13214E0214	97403	9	18
13213E2755	97403	7	23			10	31
13213E2800	97403	10		13214E0215	97403	9	17
13213E2801	97403	10	34			10	30
13213E2802	97403	10	35	13214E0229	97403	6	20
13213E2803-1	97403	10	16	13214E0240	97403	9	26
13213E2803-2	97403	10	15			10	40
13213E2805	97403	10	10	13214E0241	97403	9	24
13213E2806-1	97403	10	21	13214E0242	97403	9	25
13213E2806-2	97403	10	22			10	37
13213E2807	97403	10	33	13214E0260	97403	5	63
13213E4065	97403	3	4			7	44
13213E5162	97403	5	68	13214E0280	97403	5	57
13213E5164	97403	5	70	13215E6097	97403	6	21
13214E0101	97403	2	15	13217E1755	97403	7	1
13214E0104	97403	2	14	13217E6391	97403	3	27
13214E0105	97403	2	11	13217E6396	97403	5	1
13214E0107	97403	2	9	13217E6402-10	97403	5	4
						7	4

TM5-6115-323-24P
T.O.35C2-3-385-4
SL4-07609A/07610A

SECTION IV. INDEX-NATIONAL STOCK NUMBER AND REFERENCE NUMBER
CROSS-REFERENCE TO FIGURE AND ITEM NUMBER

REFERENCE NO.	MFG. CODE	FIG. NO.	ITEM NO.	REFERENCE NO.	MFG. CODE	FIG. NO.	ITEM NO.
13218E0182-23	97403	3	10				
13220E8321	97403	5	69				
1561	83330	6	23				
245AL	08556	5	26				
38TB8	81349	5	53				
4-2-070103BA	81343	3	14				
511-041800	78189	7	18				
69-539-1	30554	3	7				
69-561-1	30554	5	8				
69-561-1		5	11				
		7	8				
73-0506-5	30554	5	65				
73-0506-6	30554	7	47				
87-500-1	30554	3	11				
9786E50-2	02978	1	5				

By Order of the Secretaries of the Army, Air Force and Marine Corps:

JOHN A. WICKHAM, JR.
General, United States Army
Chief of Staff

Official:

R.L.DILWORTH
Brigadier General, United States Army
The Adjutant General

CHARLES A. GABRIEL, General USAF
Chief of Staff

Official:

EARL T. O'LOUGHLIN
General, USAF, Commander, Air Force
Logistics Command

GEORGE B. CRIST
Lieutenant General, USMC
Deputy Chief of Staff for Installations and Logistics

DISTRIBUTION:

To be distributed in accordance with DA Form 12-25A, Organizational, and Direct Support and General Support Maintenance Requirements for Generator Set, Gas Driven, Skid Mounted, 120/240V, AC, 28V DC, 1.5KW, 1PH (60HZ AC: MEP-015A; 60HZ DC MEP-025A).

RECOMMENDED CHANGES TO EQUIPMENT TECHNICAL PUBLICATIONS



THEN... JOT DOWN THE DOPE ABOUT IT ON THIS FORM. CAREFULLY TEAR IT OUT. FOLD IT AND DROP IT IN THE MAIL!

SOMETHING WRONG WITH THIS PUBLICATION?

FROM: (PRINT YOUR UNIT'S COMPLETE ADDRESS)
PFC JOHN DOE
COA, 3d ENGINEER BN
FT. LEONARDWOOD, MD 63108
 DATE SENT

PUBLICATION NUMBER
 TM 5-6115-323-24P

PUBLICATION DATE
 1 May 86

PUBLICATION TITLE
 Generator Set, Gasoline Engine
 Driven, Models MEP-015A, MEP-025A

BE EXACT... PIN-POINT WHERE IT IS

PAGE NO	PARA-GRAPH	FIGURE NO	TABLE NO
6	2-1 a		
B1		4-3	
125	line 20		

IN THIS SPACE TELL WHAT IS WRONG AND WHAT SHOULD BE DONE ABOUT IT:

In line 6 of paragraph 2-1a the manual states the engine has 6 Cylinders. The engine on my set only has 4 Cylinders. Change the manual to show 4 Cylinders.

Callout 16 on figure 4-3 is pointing at a bolt. In key to figure 4-3, item 16 is called a shim - Please Correct one or the other.

I ordered a gasket, item 19 on figure B-16 by NSN 2 910-00-762-3001. I got a gasket but it doesn't fit. Supply says I got what I ordered, so the NSN is wrong. Please give me a good NSN

PRINTED NAME, GRADE OR TITLE, AND TELEPHONE NUMBER

JOHN DOE, PFC (268) 317-7111

SIGN HERE

JOHN DOE

DA FORM 1 JUL 79 2028-2

PREVIOUS EDITIONS ARE OBSOLETE.

DRSTS-M Overprint 1, 1 Nov 80

P.S.--IF YOUR OUTFIT WANTS TO KNOW ABOUT YOUR RECOMMENDATION MAKE A CARBON COPY OF THIS AND GIVE IT TO YOUR HEADQUARTERS

TEAR ALONG PERFORATED LINE

FILL IN YOUR
UNIT'S ADDRESS

FOLD BACK

DEPARTMENT OF THE ARMY

OFFICIAL BUSINESS
PENALTY FOR PRIVATE USE \$300

POSTAGE AND FEES PAID
DEPARTMENT OF THE ARMY
DOD 314



COMMANDER
U S ARMY TROOP SUPPORT COMMAND
ATTN: AMSTR-MCTS
4300 GOODFELLOW BOULEVARD
ST. LOUIS, MO 63120-1798

TEAR ALONG PERFORATED LINE

RECOMMENDED CHANGES TO EQUIPMENT TECHNICAL PUBLICATIONS



THEN... JOT DOWN THE DOPE ABOUT IT ON THIS FORM. CAREFULLY TEAR IT OUT, FOLD IT AND DROP IT IN THE MAIL!

SOMETHING WRONG WITH THIS PUBLICATION?

FROM: (PRINT YOUR UNIT'S COMPLETE ADDRESS)

DATE SENT

PUBLICATION NUMBER

TM 5-6115-323-24P

PUBLICATION DATE

1 May 86

PUBLICATION TITLE

Generator Set, Gasoline Engine Driven, Models MEP-015A, MEP-025A

BE EXACT... PIN-POINT WHERE IT IS

PAGE NO

PARA-GRAPH

FIGURE NO

TABLE NO

IN THIS SPACE TELL WHAT IS WRONG AND WHAT SHOULD BE DONE ABOUT IT:

TEAR ALONG PERFORATED LINE

PRINTED NAME, GRADE OR TITLE, AND TELEPHONE NUMBER

SIGN HERE:

DA FORM 2028-2
1 JUL 79

PREVIOUS EDITIONS ARE OBSOLETE.
DRSTS-M Overprint 2, 1 Nov 80.

P.S.--IF YOUR OUTFIT WANTS TO KNOW ABOUT YOUR RECOMMENDATION MAKE A CARBON COPY OF THIS AND GIVE IT TO YOUR HEADQUARTERS.

1 Nov 80

FILL IN YOUR
UNIT'S ADDRESS

FOLD BACK

DEPARTMENT OF THE ARMY

OFFICIAL BUSINESS
PENALTY FOR PRIVATE USE \$300

POSTAGE AND FEES PAID
DEPARTMENT OF THE ARMY
DOD 314



TEAR ALONG PERFORATED LINE

COMMANDER
U S ARMY TROOP SUPPORT COMMAND
ATTN: AMSTR-MCTS
4300 GOODFELLOW BOULEVARD
ST. LOUIS, MO 63120-1798

FILL IN YOUR
UNIT'S ADDRESS

FOLD BACK

DEPARTMENT OF THE ARMY

OFFICIAL BUSINESS
PENALTY FOR PRIVATE USE \$300

POSTAGE AND FEES PAID
DEPARTMENT OF THE ARMY
DOD 314



TEAR ALONG PERFORATED LINE

COMMANDER
U S ARMY TROOP SUPPORT COMMAND
ATTN: AMSTR-MCTS
4300 GOODFELLOW BOULEVARD
ST. LOUIS, MO 63120-1798

FILL IN YOUR
UNIT'S ADDRESS

FOLD BACK

DEPARTMENT OF THE ARMY

OFFICIAL BUSINESS
PENALTY FOR PRIVATE USE \$300

POSTAGE AND FEES PAID
DEPARTMENT OF THE ARMY
DOD 314



TEAR ALONG PERFORATED LINE

COMMANDER
U S ARMY TROOP SUPPORT COMMAND
ATTN: AMSTR-MCTS
4300 GOODFELLOW BOULEVARD
ST. LOUIS, MO 63120-1798

The Metric System and Equivalent

Linear Measure

1 centimeter = 10 millimeters = .39 inch
 1 decimeter = 10 centimeters = 3.94 inches
 1 meter = 10 decimeters = 39.37 inches
 1 dekameter = 10 meters = 32.8 feet
 1 hectometer = 10 dekameters = 328.08 feet
 1 kilometer = 10 hectometers = 3,280.8 feet

Weights

1 centigram = 10 milligrams = .15 grain
 1 decigram = 10 centigrams = 1.54 grains
 1 gram = 10 decigrams = .035 ounce
 1 dekagram = 10 grams = .35 ounce
 1 hectogram = 10 dekagrams = 3.52 ounces
 1 kilogram = 10 hectograms = 2.2 pounds
 1 quintal = 100 kilograms = 220.46 pounds
 1 metric ton = 10 quintals = 1.1 short tons

Liquid Measure

1 centiliter = 10 milliliters = .34 fl. ounce
 1 deciliter = 10 centiliters = 3.38 fl. ounces
 1 liter = 10 deciliters = 33.81 fl. ounces
 1 dekaliter = 10 liters = 2.64 gallons
 1 hectoliter = 10 dekaliters = 26.42 gallons
 1 kiloliter = 10 hectoliters = 264.18 gallons

Square Measure

1 sq. centimeter = 100 sq. millimeters = .155 sq. inch
 1 sq. decimeter = 100 sq. centimeters = 15.5 sq. inches
 1 sq. meter (centare) = 100 sq. decimeters = 10.76 sq. feet
 1 sq. dekameter (are) = 100 sq. meters = 1,076.4 sq. feet
 1 sq. hectometer (hectare) = 100 sq. dekameters = 2.47 acres
 1 sq. kilometer = 100 sq. hectometers = .386 sq. mile

1 cu. centimeter = 1000 cu. millimeters = .06 cu. inch
 1 cu. decimeter = 1000 cu. centimeters = 61.02 cu. inches
 1 cu. meter = 1000 cu. decimeters = 35.31 cu. feet

Approximate Conversion Factors

To Change	To	Multiply by	To change	To	Multiply by
inches	centimeters	2.540	ounce-inches	newton-meters	.007062
feet	meters	.305	centimeters	inches	.394
yards	meters	.914	meters	feet	3.280
miles	kilometers	1.609	meters	yards	1.094
square inches	square centimeters	6.451	kilometers	miles	.621
square feet	square meters	.093	square centimeters	square inches	.155
square yards	square meters	.836	square meters	square feet	10.764
square miles	square kilometers	2.590	square meters	square yards	1.196
acres	square hectometers	.405	square kilometers	square miles	.386
cubic feet	cubic meters	.028	square hectometers	acres	2.471
cubic yards	cubic meters	.765	cubic meters	cubic feet	35.315
fluid ounces	milliliters	29.573	cubic meters	cubic yards	1.308
pints	liters	.473	milliliters	fluid ounces	.034
quarts	liters	.946	liters	pints	2.113
gallons	liters	3.785	liters	quarts	1.057
ounces	grams	28.349	liters	gallons	.264
pounds	kilograms	.454	grams	ounces	.035
short tons	metric tons	.907	kilograms	pounds	2.205
pound-feet	newton-meters	1.356	metric tons	short tons	1.102
pound-inches	newton-meters	.11296			

Temperature (Exact)

"F	Fahrenheit temperature	5/9 (after subtracting 32)	Celsius temperature	°C
----	------------------------	----------------------------	---------------------	----

